

# **MITSUBISHI PRODUCT UPDATE PAJERO**



# MY10 PAJERO

## Improved Features

- New Diesel Engine (Diesel Models only)
- Navigation System (All Pajero Models)
- Alarm system (All Pajero Models)



# MY10 PAJERO

- Initial Production Month April 2010
- Expected Sale month in SA June 2010

## Vehicle Specification

<b>3.2L DI-D</b>	<b>Diesel Engine</b>
Transmission:	5 Speed Auto
Tyres:	17"
Power Output:	140kW/3800rpm
	441Nm/2000rpm
Fuel tank capacity:	69L & 88L

**\* Engine Specification Change on Diesel Only**

<b>3.8L GLS SWB</b>	<b>Petrol Engine</b>
Transmission:	5 Speed Auto
Tyres:	17"
Power Output:	182kW/6000rpm
	329Nm/2750rpm
Fuel tank capacity:	69L

<b>3.8L GLS LWB</b>	<b>Petrol Engine</b>
Transmission:	5 Speed Auto
Tyres:	17"
Power Output:	184kW/6000rpm
	329Nm/2750rpm
Fuel tank capacity:	88L





**MY10 PAJERO 4M41 DI-DC High Power Engine**



# MY10 PAJERO 4M41 DI-DC High Power Engine

## Main Feature:

- High Power - **140kW 441 Nm** (for South Africa) 07MY 121kW 373Nm
- Modified Engine detail
  - Cylinder head (Intake port form has been changed)
  - Piston (Combustion chamber has been changed)
  - etc.
- Modified Swirl control valve (Swirl ratio and port form has been changed)
- Changed Turbo charger (Large size turbo charger has been adopted)
- Changed Injector (Improved combustion efficiency)
- New Automatic Transmission



# MY10 PAJERO 4M41 DI-DC High Power Engine

Performance curve  
(For South Africa, A/T)

South Africa A/T	MY10 High Power	07MY
Max. Output (kW / rpm)	140 / 3800	121 / 3500
Max. Torque (Nm / rpm)	441 / 2000	373 / 2000

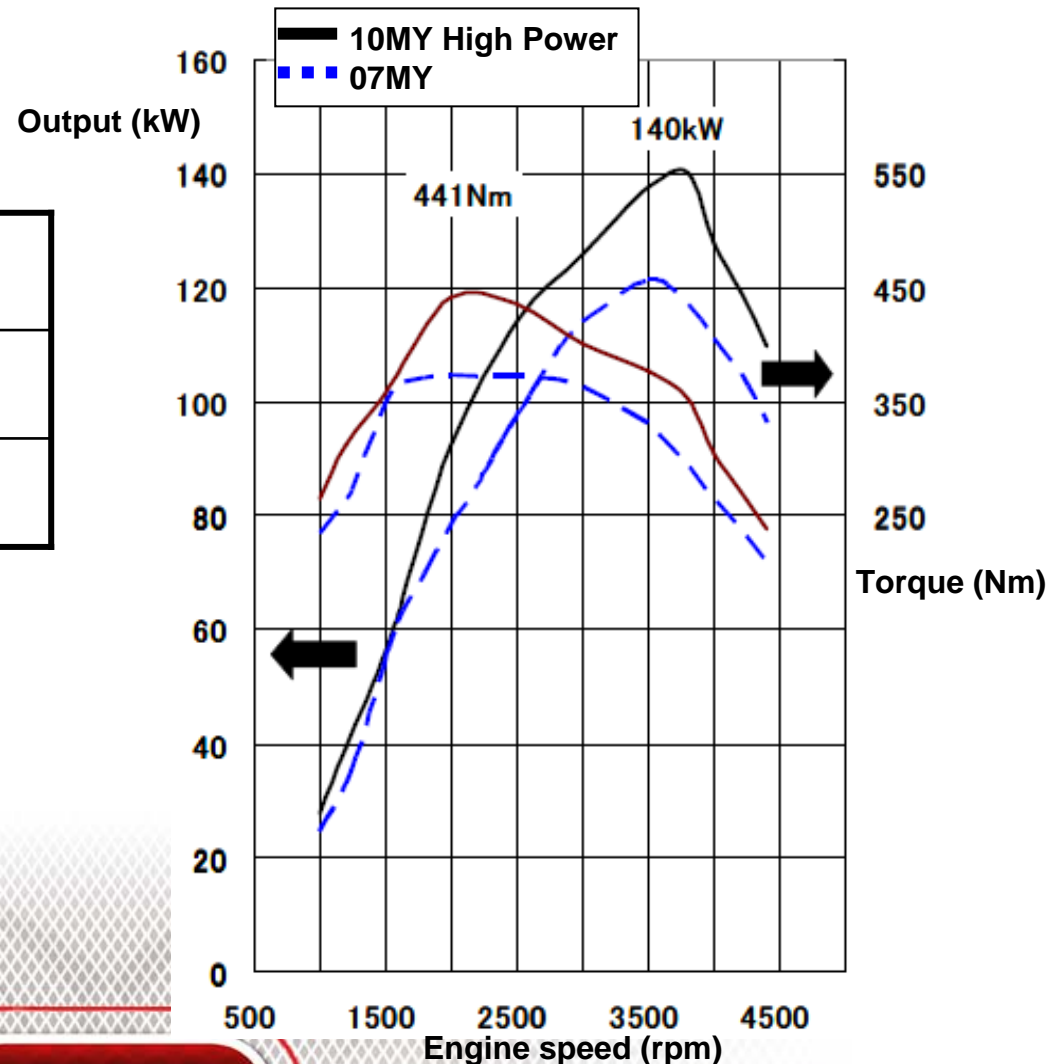

# MY10 PAJERO 4M41 DI-DC High Power Engine

Water pump  
(Improved pump impeller)

Intake manifold  
(Modified port form)

Injector  
(Modified)

Cylinder head  
(Modified)

Turbo charger  
(Large size VG turbo)

Thermostat  
(Changed opening temp.)

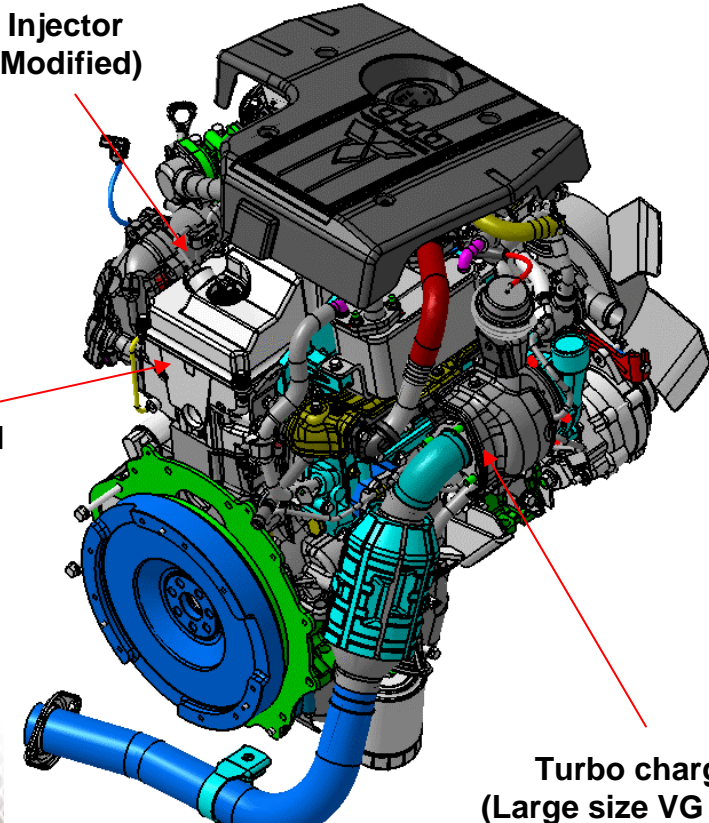
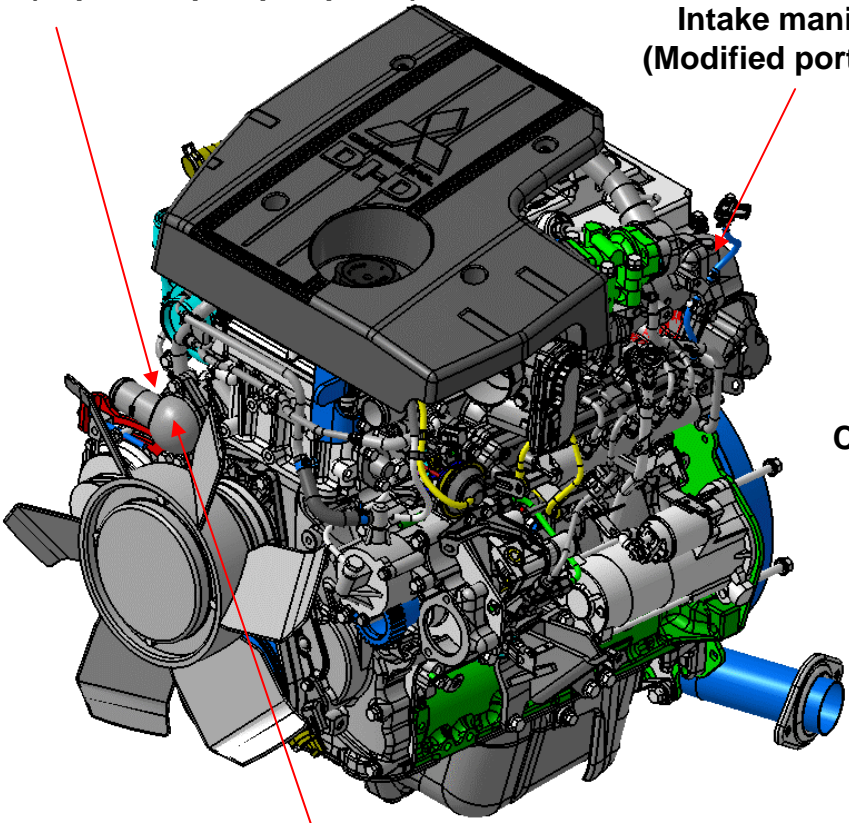

# Pajero Alarm System

## Theft alarm sensor

Theft siren sensor consists of supersonic wave sensor and inclination sensor inside.

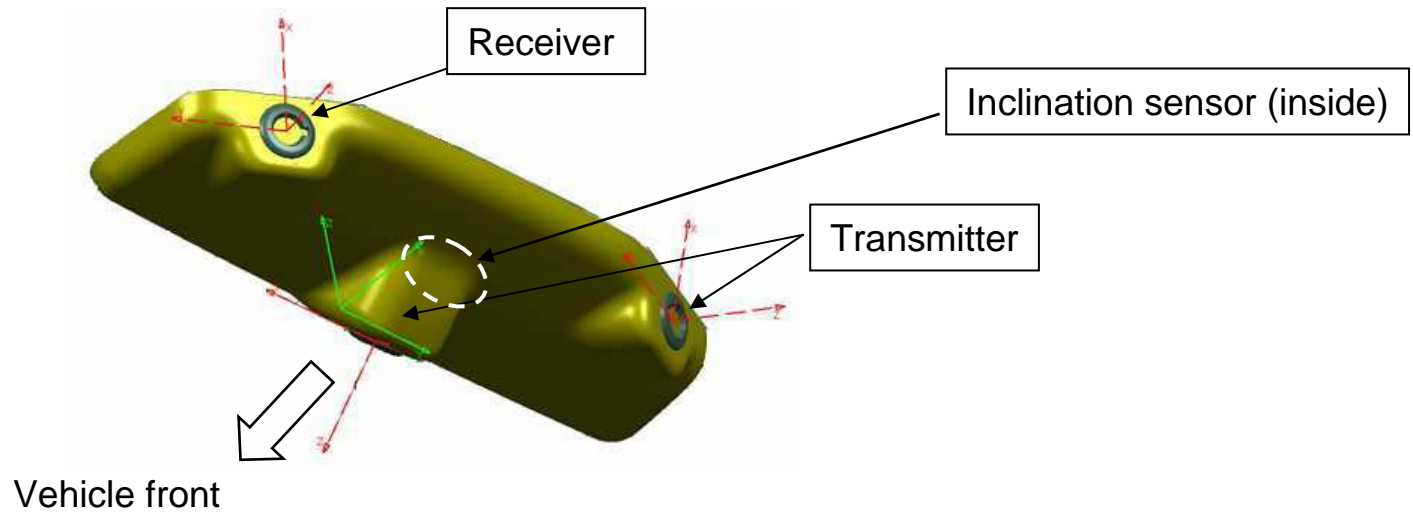

# Pajero Navigation System



# Main Menu

- 6.5" Touch screen monitor
- HD TFT digital screen 800 \* 480
- Remote control
- Integrated steering wheel controls

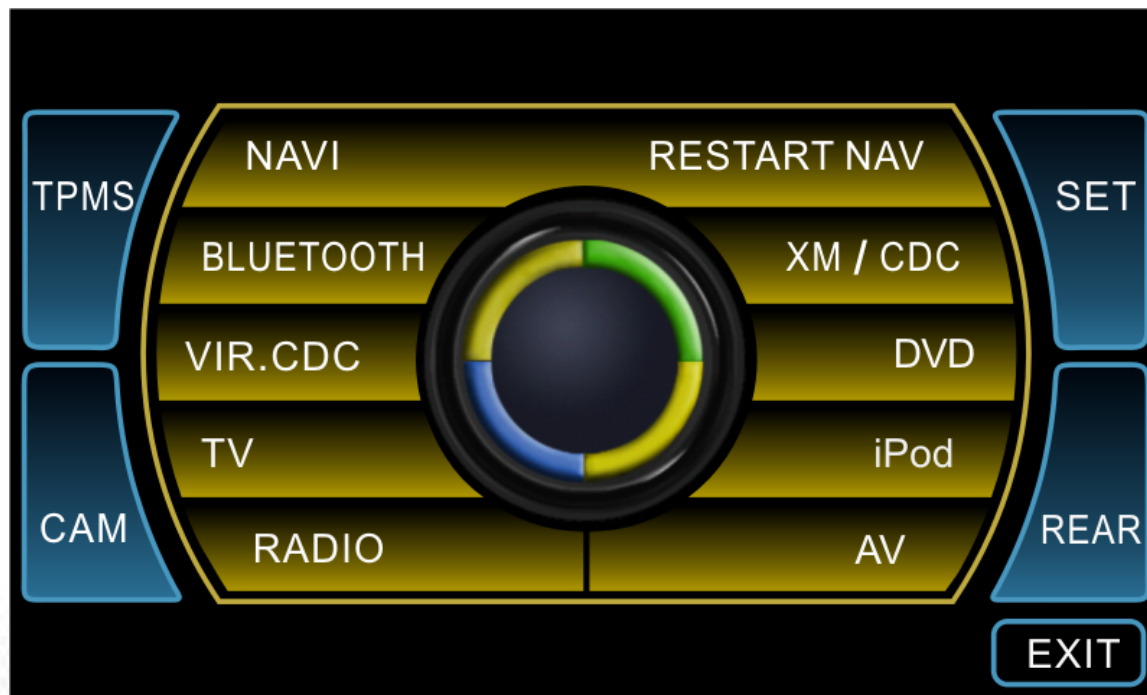

# Radio

- Highly sensitive FM / AM radio receiver with RDS
- Preset stations
- TF, AF and PTY functions

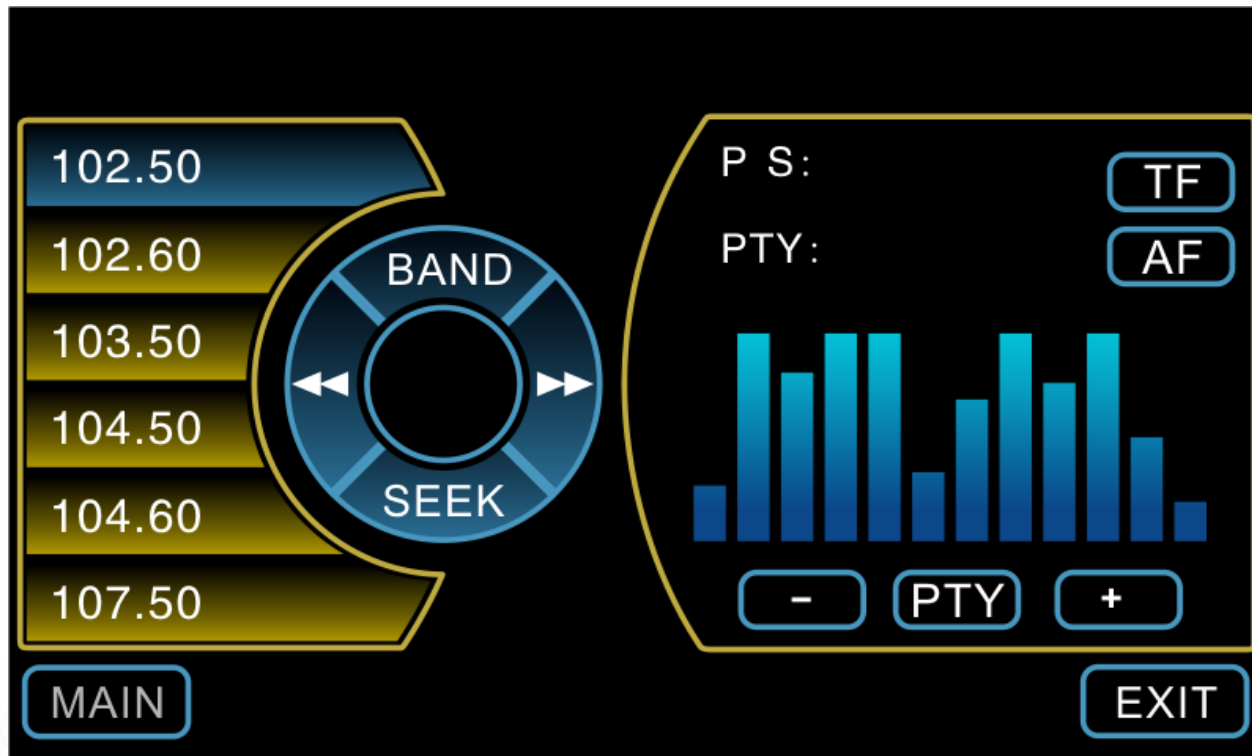

# DVD/CD Player

- Plays CD, DVD, CD-R, VCD, MP3, JPEG, MPEG4, etc
- Standard DVD operation (subtitles, zoom, parental control, etc.)



# Bluetooth

- Dial, answer and reject calls from touch screen
- Incoming call number is displayed
- Call register can be downloaded
- Separate microphone for improved sound quality
- A2DP (play music via Bluetooth)

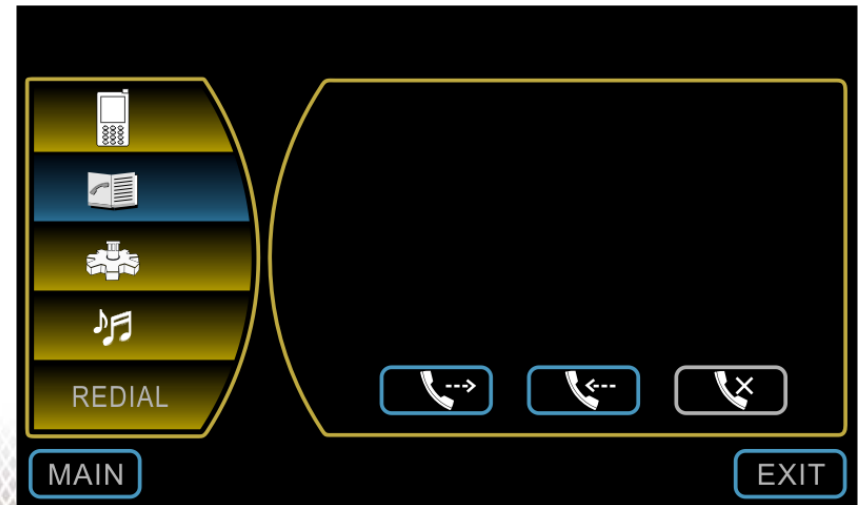

# Bluetooth

- Dial, answer and reject calls from touch screen
- Incoming call number is displayed
- Call register can be downloaded
- Separate microphone for improved sound quality
- A2DP (play music via Bluetooth)

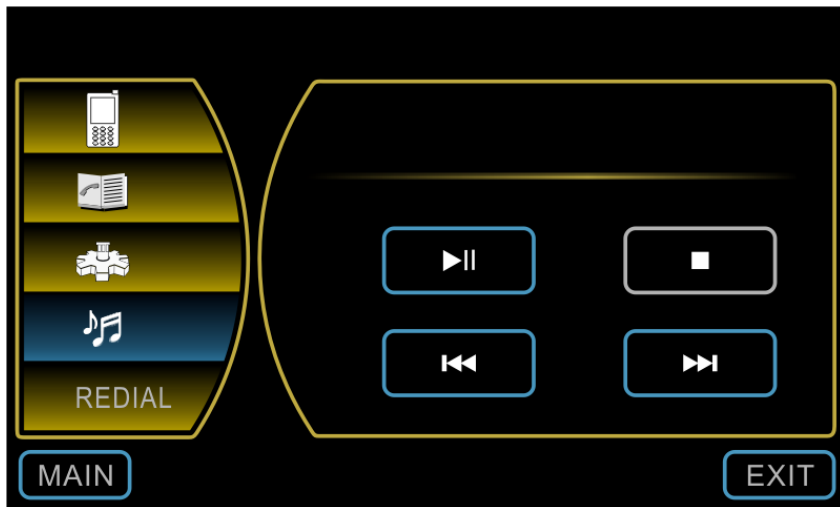

# iPod Connection

- Full iPod functionality from touch screen
- Charges most iPod's

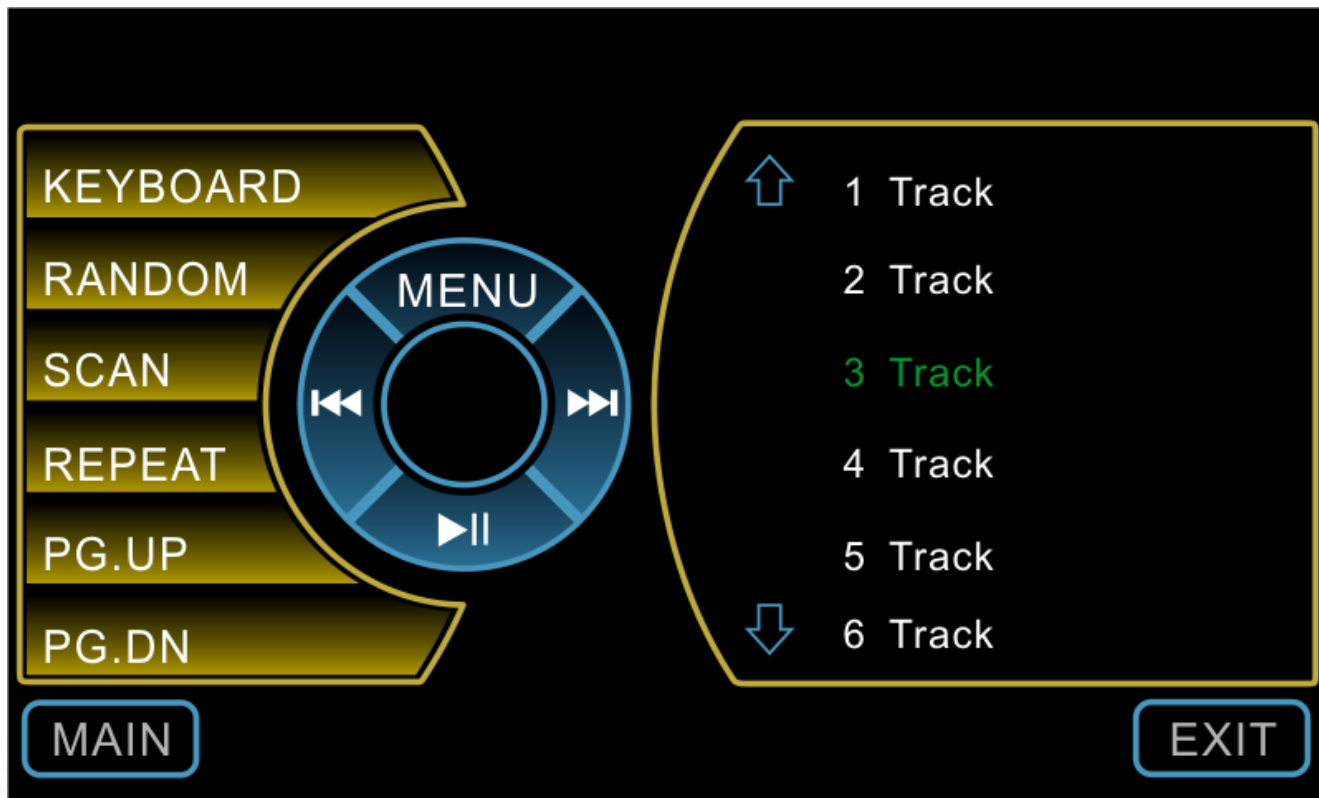

# Virtual CDC

- Copy 5 audio discs
- Can copy song by song

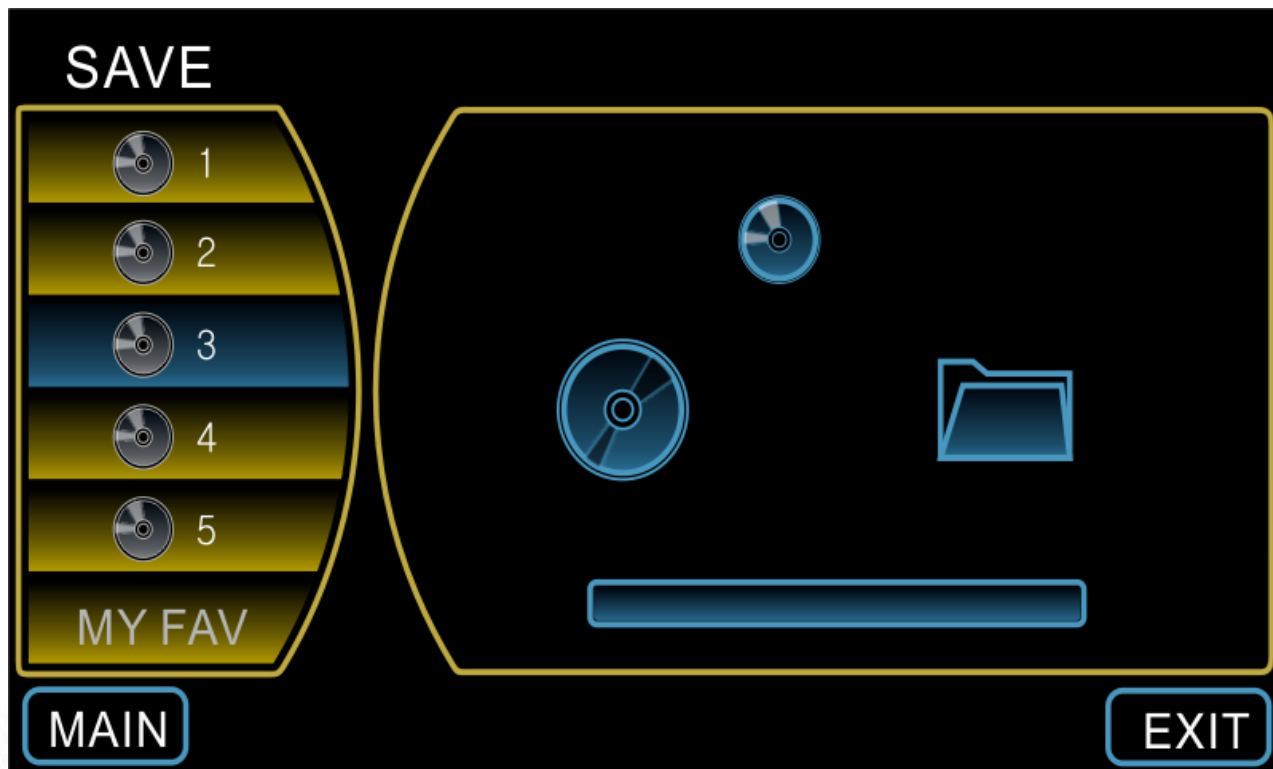

# Tyre Pressure Monitoring system

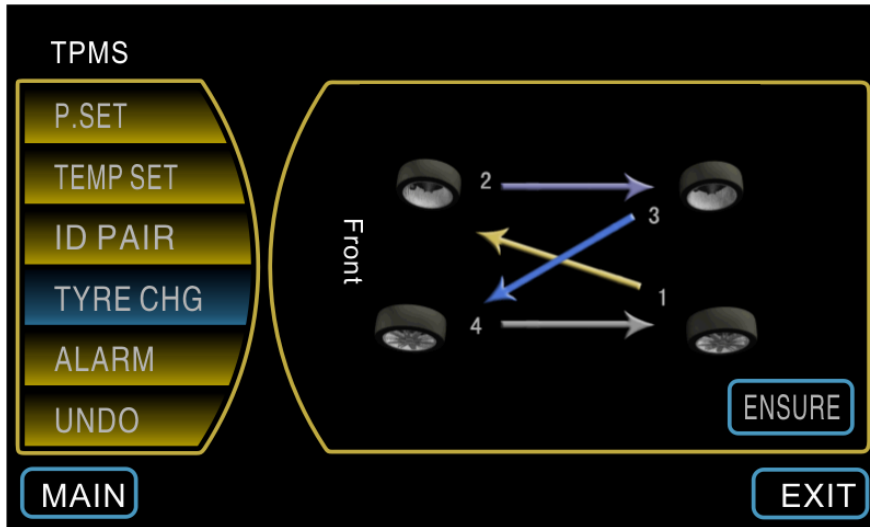

- Displays tyre pressure and temperature
- Driver alerts
- ID Pairing, tyre change, etc.

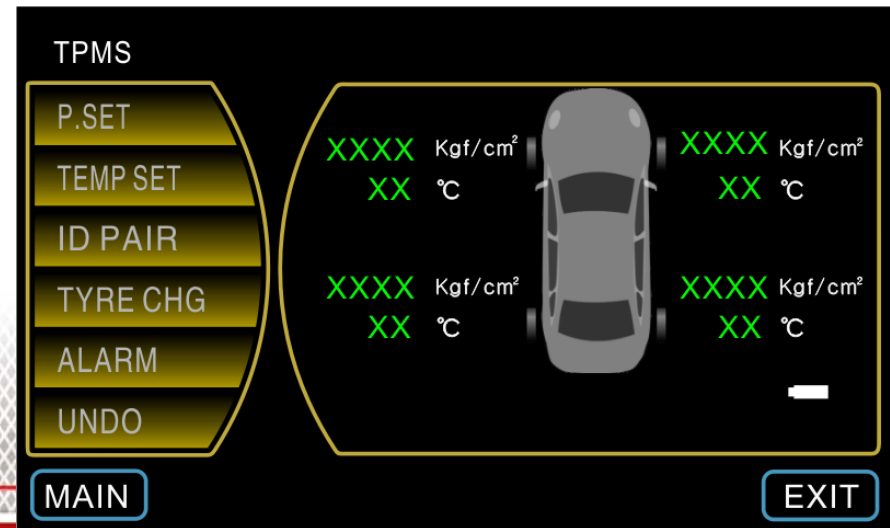
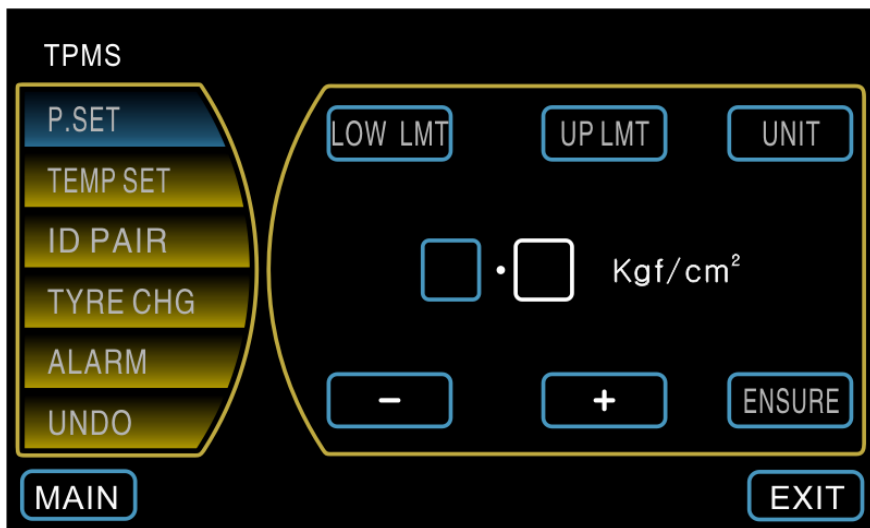

# Dual Zone

- Select output to rear monitor/s
- Does not affect the operation of main system

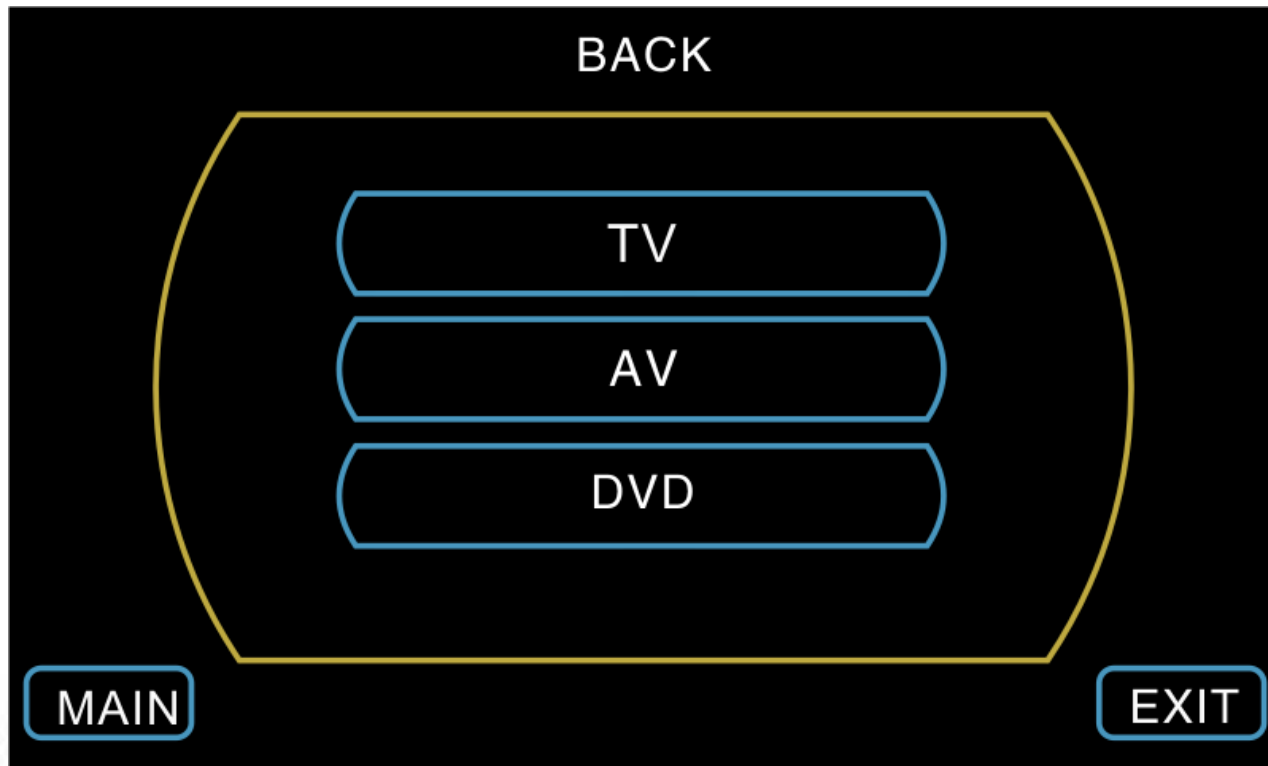

# Safety

- Displays when playing a DVD while driving
- Ensures the safety of your customers

## CAUTION

Video viewing is not available while driving. Use this system only when traffic conditions permit, safe vehicle operation is the driver's responsibility. For further details see your user's manual.



# Garmap Navigation



- Loaded with latest Garmap mapping
- Download updates over the internet
- Navigate while listening to radio, CD, iPod, etc
- Voice prompts will mute music

