

·ZEXEL·

Bosch Group

Pub. No. EE14E-11190

SERVICE MANUAL

ADJUSTMENT
& INSPECTION

COVEC-F



WARNINGS

The following definitions and warning signs are used in this service manual. These are extremely important to safe operation. Important points are described to prevent bodily injury and property damage. They must be fully understood before beginning COVEC-F maintenance.



Improper maintenance can result in injury and property damage.

MEANINGS OF MARKS

The following marks are used in this service manual to facilitate correct COVEC-F maintenance.

Advice Procedures that must be performed to enable the best possible COVEC-F maintenance.

Note Information assisting in the best possible COVEC-F maintenance.

FOREWORD

This service manual describes service precautions and the adjustment and inspection of COVEC-F (Computed VE pump Control system-Full).

Refer to the separate service manuals listed below to facilitate COVEC-F maintenance.

This manual is intended for use by vehicle maintenance technicians or persons with an adequate knowledge of injection pumps.

The contents of the manual, including illustrations, drawings and specifications were the latest available at the time of printing.

The right is reserved to make changes in specifications and procedures at any time without notice.

BOSCH K.K.

Sales Automotive Aftermarket Division

Service manual	Publication number
COVEC-F Construction and Operation	EE14E-11081
COVEC-F Repair Service and Maintenance	EE14E-11102
INJECTION PUMP TEST BENCH 10NP & 20 NP, Operation	EC18E-11081
CONTINUOUS MEASURING DEVICE ZCM & ZCD, Operation	EC18E-11091
CONTROLLER ASSEMBLY MC-02 FOR VRZ & COVEC-F, Operation	EC14E-11021
MC-02 TESTER SOFTWARE, ADJUSTMENT AND INSPECTION DATA, Installation	ED14E-11010
ECU ASSEMBLY, ADJUSTMENT AND INSPECTION DATA, Installation	ED14E-11020

CONTENTS

	Page
1 SERVICE PRECAUTIONS	1
2 FEATURES	2
3 SPECIAL TOOLS	3
4 ADJUSTMENT	9
1. ADJUSTMENT CONDITIONS	9
2. CONTROLLER UNIT CONTROLS	13
3. PUMP ADJUSTMENT TOOL FLOW CHART	16
4. PUMP ADJUSTMENT TOOL MONITOR SCREEN	17
5. PUMP ADJUSTMENT TOOL MONITOR SCREEN OUTLINE	18
6. MANUAL OPERATION DISPLAY	19
7. WORKSHOP DISPLAY	19
8. ADJUSTMENT	21
5 INSPECTION	40
6 TIGHTENING TORQUES	49
7 PART NUMBER EXPLANATION	50
1. INJECTION PUMP ASSEMBLY NUMBER	50
2. BOSCH TYPE NUMBER	50

1 SERVICE PRECAUTIONS

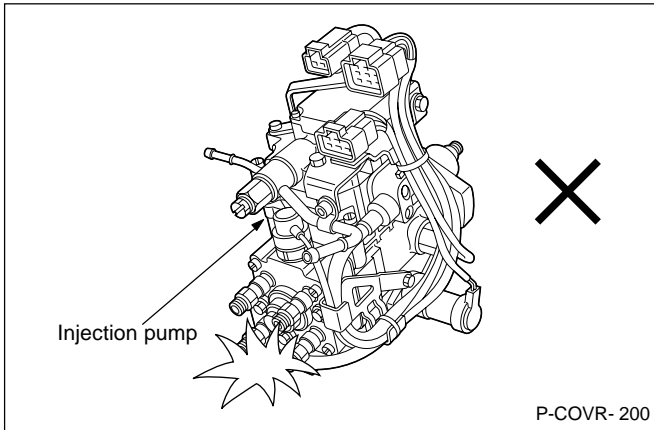

[1] Carrying the injection pump

- Never knock or drop the injection pump when carrying it.

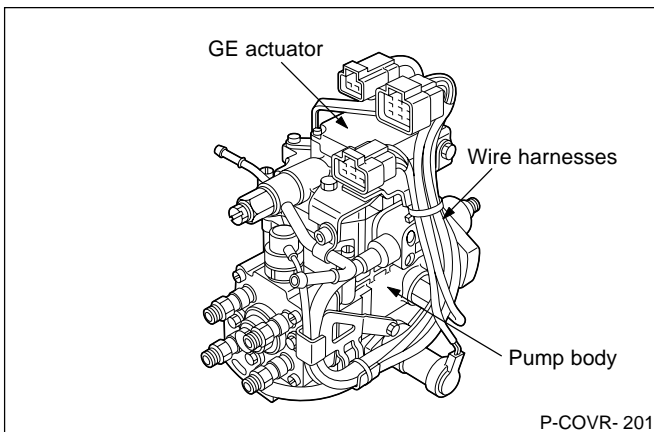

- When carrying the injection pump, hold the pump by the bottom of the pump body.

⚠ CAUTION

Never hold the pump by the GE actuator or the harnesses.

Holding the pump by these components may result in damage or injury.

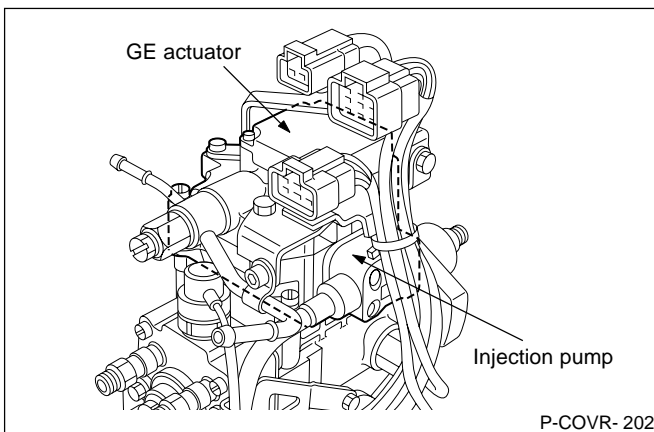

[2] Disassembly and reassembly

- Only the mechanical components of the injection pump body can be disassembled and reassembled.

Advice

Do not disassemble the GE actuator other than directed in this manual.

- The GE actuator consists of electrical components. Do not damage them.

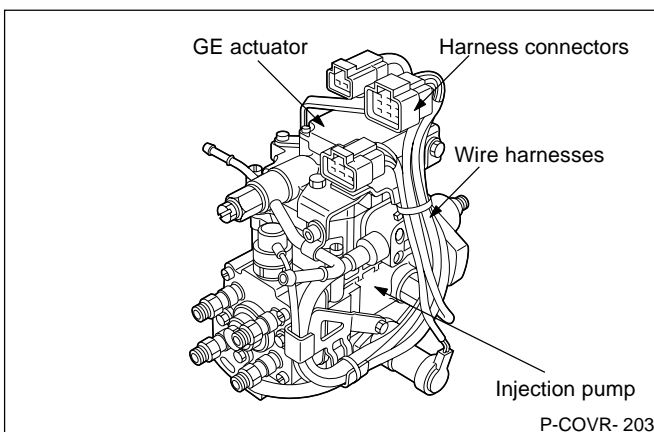

- When cleaning the injection pump, do not clean the GE actuator, the harnesses, or the harness connectors using fuel oil. Use only clean waste cloth.

2 FEATURES

Q ADJUSTMENT ROM

[1] Purpose

The purpose of improving the Q adjustment ROM was to compensate for variations in injection quantities between individual injection pumps.

[2] Comparison of Q adjustment ROM features

The system includes a ROM (ie, the Q adjustment ROM) onto which injection quantity adjustment data (ie, Q adjustment data) for individual pumps has been written.

Current Q adjustment compensation system	Improved Q adjustment compensation system
<ul style="list-style-type: none">• Compensation limited to full Q adjustment compensation• A single device is necessary for compensation only at a single point.	<ul style="list-style-type: none">• Multiple point compensation possible using a single component

[3] Compensation example

With the Q adjustment ROM, multiple point compensation is possible for a single component. As shown in the figure below, 3 speed patterns x 3 partial load patterns give 9 compensation locations:

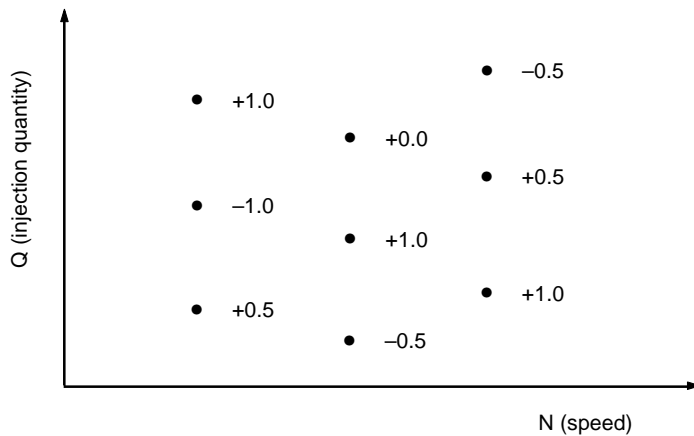

[1] Adjustment tools

(1) Bosch Automotive System specifications

Key no	RBAJ part no	Bosch part no	Part name	Qty	Remarks
1	105796-0000	1 688 010 129	Fixing stand	1	For driving pump; center height: 125 mm
2	157811-0521	9 681 610 291	Flange	1	For fixing pump
3	105780-8190	9 430 610 134	Nozzle, nozzle holder assembly	4	New injection system (nozzle holder part no: 105780-2150, nozzle part no: 105780-0060)
4	157805-7320	9 681 611 029	Injection pipe	4	Inner dia $\phi 2$ x outer dia $\phi 6$ - length 450mm
5	157641-4720	9 443 612 897	Joint assembly	1	For fixing key no 3
6	157641-7020	9 443 612 976	Tube assembly	4	Used together with key no 5
7	157842-4522	9 681 610 326	Coupling	1	For driving pump (shaft dia $\phi 20$)
8	105782-8260	9 680 610 061	Measuring device	1	For measuring timer stroke (high pressure)
9	105782-8160	9 680 610 016	Measuring device	1	For measuring pre-stroke
10	157954-4100	9 681 610 942	Dial gauge	1	Used together with key no 9
11	157829-0820	9 681 610 336	Adjusting device	1	For adjusting regulating valve pressure
12	157928-2920	9 443 613 009	Pliers	1	For disassembling regulating valve
13	157829-5220	9 681 610 184	Insertor	1	For assembling regulating valve
14	157971-1020	9 443 613 442	Piping assembly	1	For test oil overflow piping
15	157641-6920	9 443 612 975	Socket assembly	10	Used together with key no 6

(2) Bosch specifications

Key no	Bosch part no	Part name	Qty	Remarks
1	1 687 010 126	VE pump overflow accessory set	1	Three-way valve (multiway cock)

Note:

Center height is the height from the center of the pump test bench's flywheel to the drive stand.

3 SPECIAL TOOLS

1. 105796-0000
(1 688 010 129)
Fixing stand

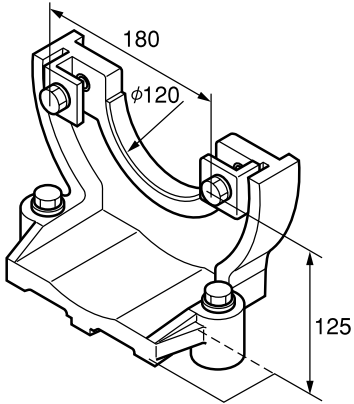

2. 157811-0521
(9 681 610 291)
Flange

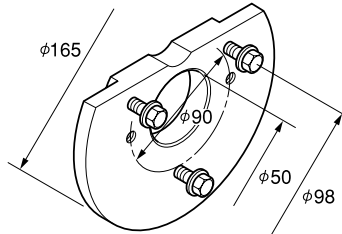

3. 105780-8190
(9 430 610 134)
Nozzle, nozzle holder assembly

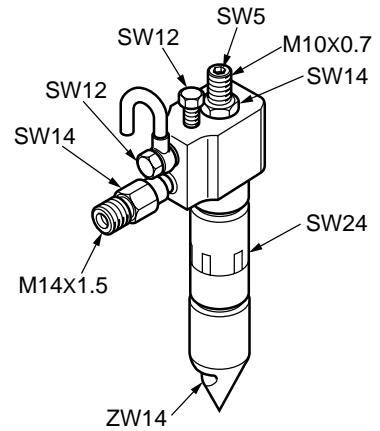

4. 157805-7320
(9 681 611 029)
Injection pipe

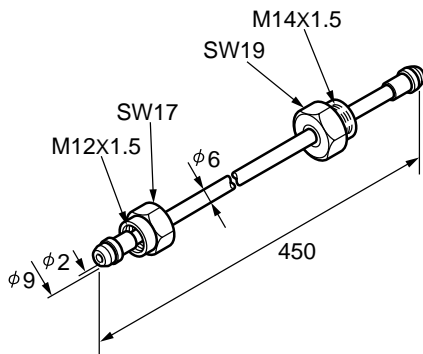

5. 157641-4720
(9 443 612 897)
Joint assembly

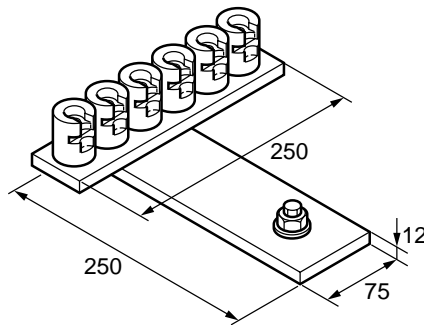

6. 157641-7020
(9 443 612 976)
Tube assembly

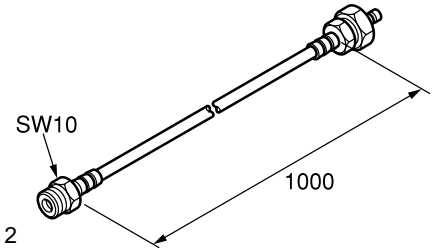

7. 157842-4522
(9 681 610 326)
Coupling

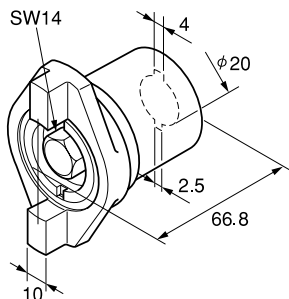

8. 105782-8260
(9 680 610 061)
Measuring device

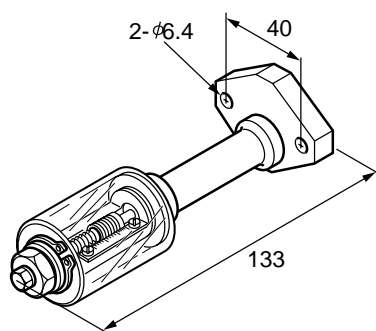

9. 105782-8160
(9 680 610 016)
Measuring device

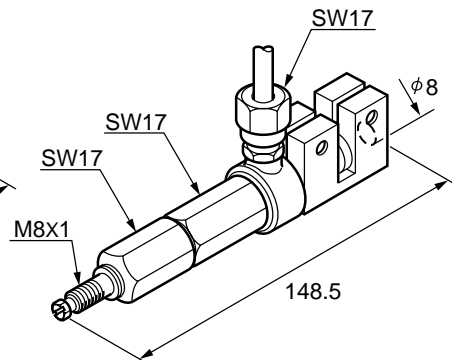

10. 157954-4100
(9 681 610 942)
Dial gauge

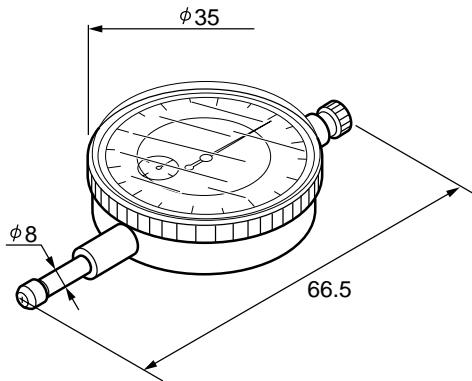

11. 157829-0820
(9 681 610 336)
Adjusting device

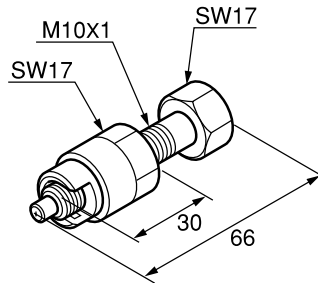

12. 157928-2920
(9 443 613 009)
Pliers

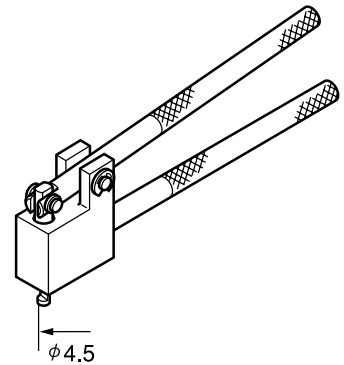

13. 157829-5220
(9 681 610 184)
Inserter

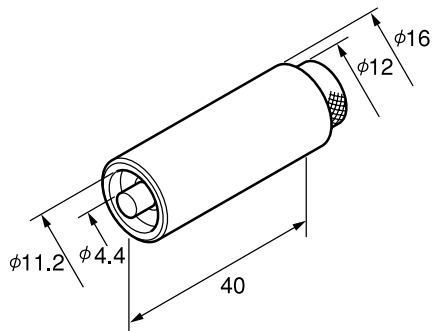

14. 157971-1020
(9 443 613 442)
Piping assembly

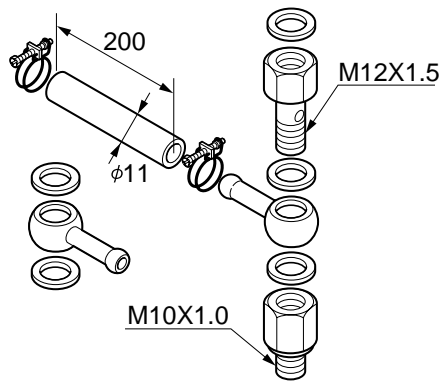

15. 157641-6920
(9 443 612 975)
Socket assembly

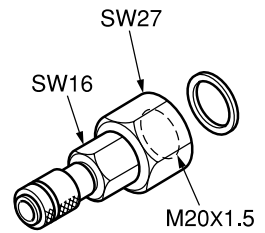

3 SPECIAL TOOLS

[2] Adjustment controller assembly construction:

Note:

The numbers in brackets below are Bosch part numbers.

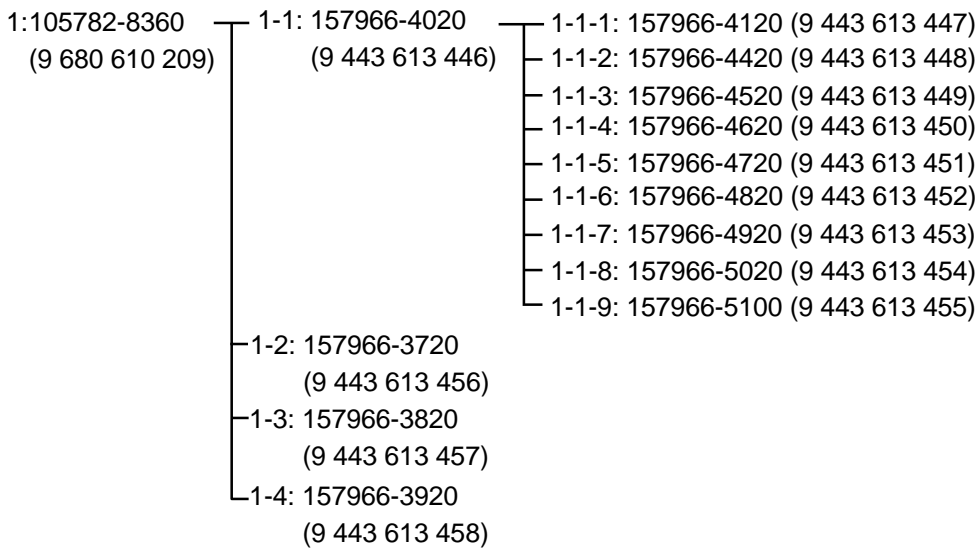

Note:

Key number 1 (RBAJ part no. 105782-8360, Bosch part no. 9 680 610 209) is used with both VRZ and COVEC-F pumps. With the COVEC-F pump, key numbers 1-1 (RBAJ part no. 157966-4020, Bosch part no. 9 443 613 446), 1-2 (RBAJ part no. 157966-3720, Bosch part no. 9 443 613 456) and 1-4 (RBAJ part no. 157966-3920, Bosch part no. 9 443 613 458) are used.

Adjustment controller assembly table (for COVEC-F)

Key no. 1: 105782-8360 (9 680 610 209)

Key no	RBAJ part no	Bosch part no	Part name	Qty	Remarks
1-1	157966-4020	9 443 613 446	CONTROLLER ASSY	1	
1-1-1	157966-4120	9 443 613 447	Controller unit	1	Checker assy
1-1-2	157966-4420	9 443 613 448	Wire harness	1	Power supply (Japan, USA)
1-1-3	157966-4520	9 443 613 449	Wire harness	1	Power supply (EC)
1-1-4	157966-4620	9 443 613 450	Wire harness	1	PC: COM1 ~ MC-02
1-1-5	157966-4720	9 443 613 451	Wire harness	1	PC: COM2 ~ MC-02
1-1-6	157966-4820	9 443 613 452	Wire harness	1	FCV GND harness
1-1-7	157966-4920	9 443 613 453	Main harness	1	Controller-Pump GE
1-1-8	157966-5020	9 443 613 454	Main harness	1	Controller-Pump ROM
1-1-9	157966-5100	9 443 613 455	CD-ROM	1	Software (Overseas Ver.) & (Calibration data) & Manual
1-2	157966-3720	9 443 613 456	ECU assembly (4D56)	1	4D56 throttle
1-4	157966-3920	9 443 613 458	ECU assembly (WL)	1	WL throttle

1-1 157966-4020
(9 443 613 446)
CONTROLLER ASSY

1-1-1 157966-4120
(9 443 613 447)
Controller unit

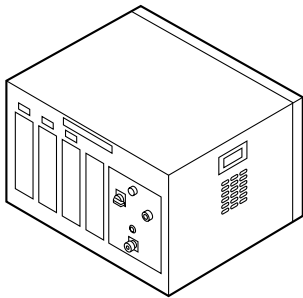

1-1-2 157966-4420
(9 443 613 448)
Wire harness

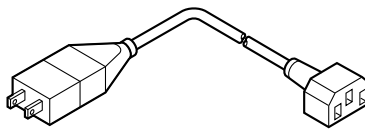

1-1-3 157966-4520
(9 443 613 449)
Wire harness

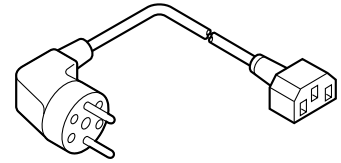

1-1-4 157966-4620
(9 443 613 450)
Wire harness

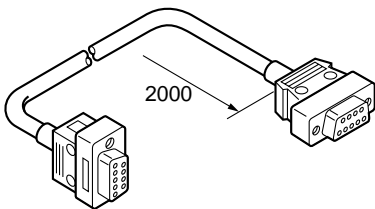

1-1-5 157966-4720
(9 443 613 451)
Wire harness

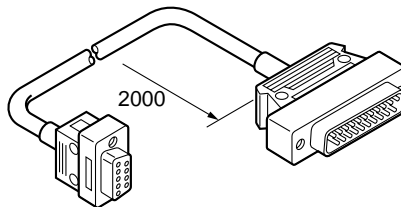

1-1-6 157966-4820
(9 443 613 452)
Wire harness

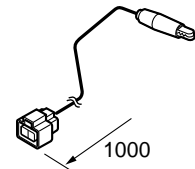

1-1-7 157966-4920
(9 443 613 453)
Main harness

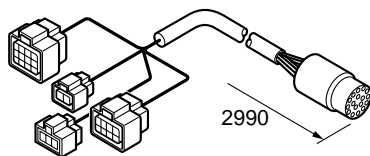

1-1-8 157966-5020
(9 443 613 454)
Main harness

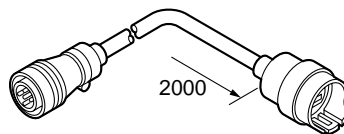

1-1-9 157966-5100
(9 443 613 455)
CD-ROM

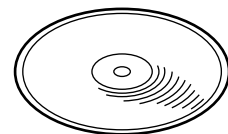

3 SPECIAL TOOLS

1-2 157966-3720
(9 443 613 456)
ECU assembly (4D56)

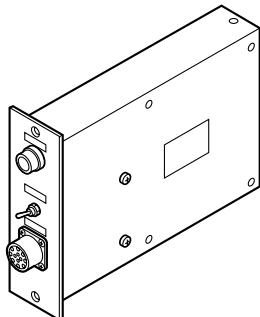

1-4 157966-3920
(9 443 613 458)
ECU assembly (WL)

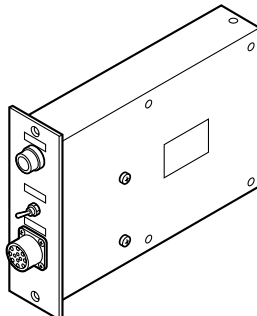

[3] Intermediate harnesses

Key no	RBAJ part no	Bosch part no	Part name	Qty	Remarks
1	157966-5620	9 443 613 459	Intermediate harness	1	4M56 Covec-F GE
2	157966-5820	9 443 613 461	Intermediate harness	1	WL Covec-F GE
3	157966-2421	9 443 613 462	Intermediate harness	1	For 4M41, 4D56 ROM

1. 157966-5620
(9 443 613 459)
Intermediate harness
(4D56)

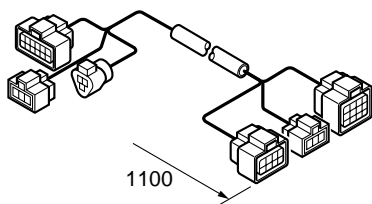

2. 157966-5820
(9 443 613 461)
Intermediate harness
(WL)

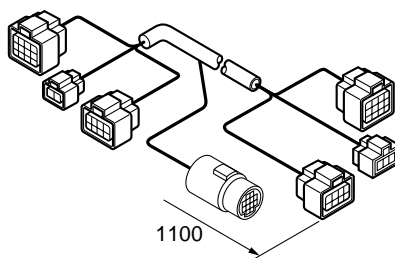

3. 157966-2421
(9 443 613 462)
Intermediate harness
(4M41, 4D56 ROM)

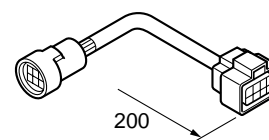

1. ADJUSTMENT CONDITIONS

[1] Test equipment

- (1) Pump test bench EPS815**
- (2) KMA802**
- (3) Adjustment software operating environment**

Windows OS	Windows 2000 PRO (at least Service Pack 2.0) English language version
Clock speed	Personal computer equipped with Pentium CPU (clock speed at least 333 MHz)
Memory	At least 128 MB usable memory
Hard disk	At least 20 MB space
Display	Resolution: at least 1027 x 768, number of display colors: high color minimum (16 bit)
Drive devices	CD-ROM drive, floppy disk drive
Additional devices	At least 2 communication ports (2 necessary for controller assembly) Mouse, keyboard

[2] Fuel piping

(1) Injection system piping diagram

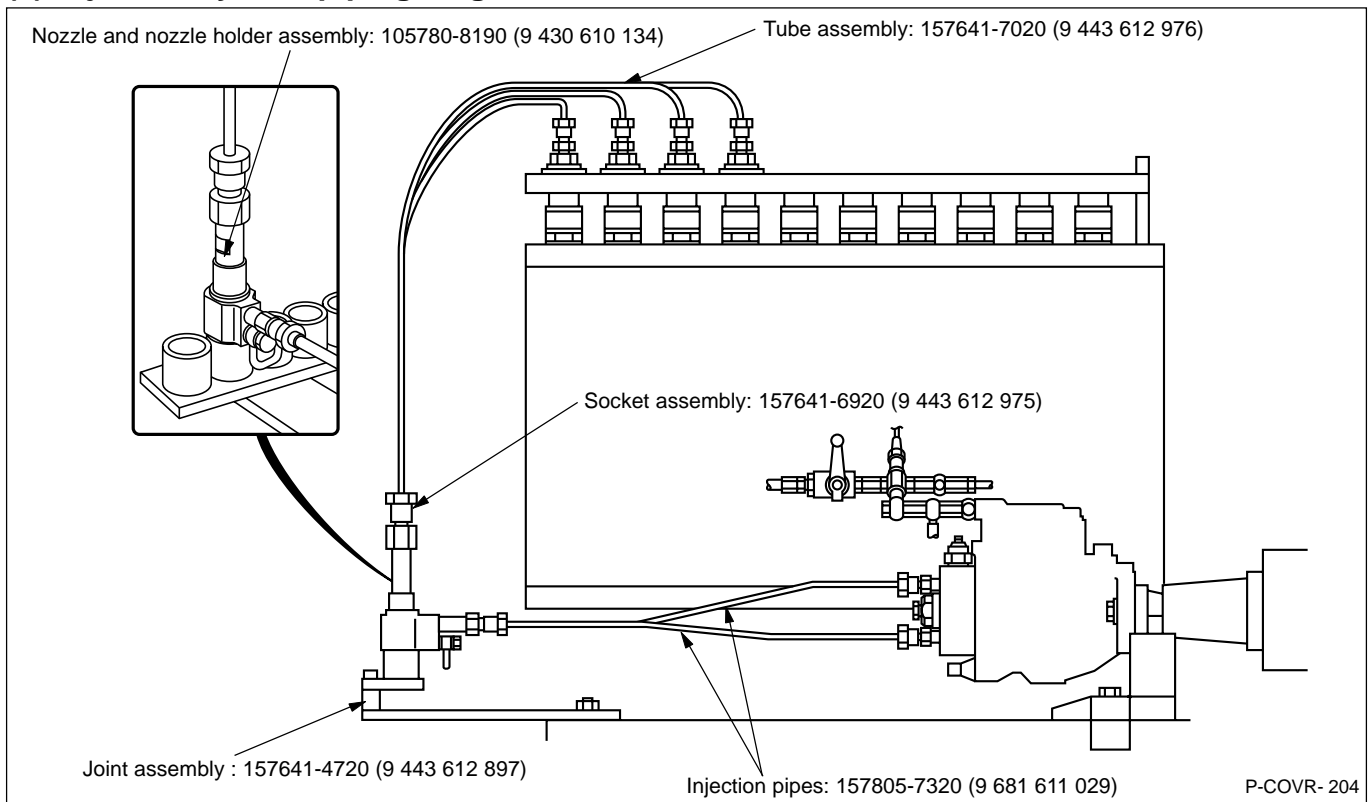

4 ADJUSTMENT

(2) Fuel piping

Key no	RBAJ part no	Bosch part no	Part name	Qty	Remarks
1	157971-1020	9 443 613 442	Piping assembly	-	For COVEC-F and VRZ overflow fuel piping
1/1	157971-1100	9 443 613 443	Bolt	1	For distributor head overflow
1/2	026512-1640	9 421 617 041	Gasket	6	For distributor head overflow
1/3	029711-2180	9 442 610 444	Eye	2	For distributor head overflow
1/4	157971-1000	9 443 613 444	Adapter	1	For distributor head overflow
1/5	017211-2010	9 442 611 983	Hose clip	2	For distributor head overflow
1/6	157986-8100	9 443 613 445	Hose	1	For distributor head overflow
1/7	026510-1340	9 442 610 043	Gasket	1	For distributor head overflow

Piping outline

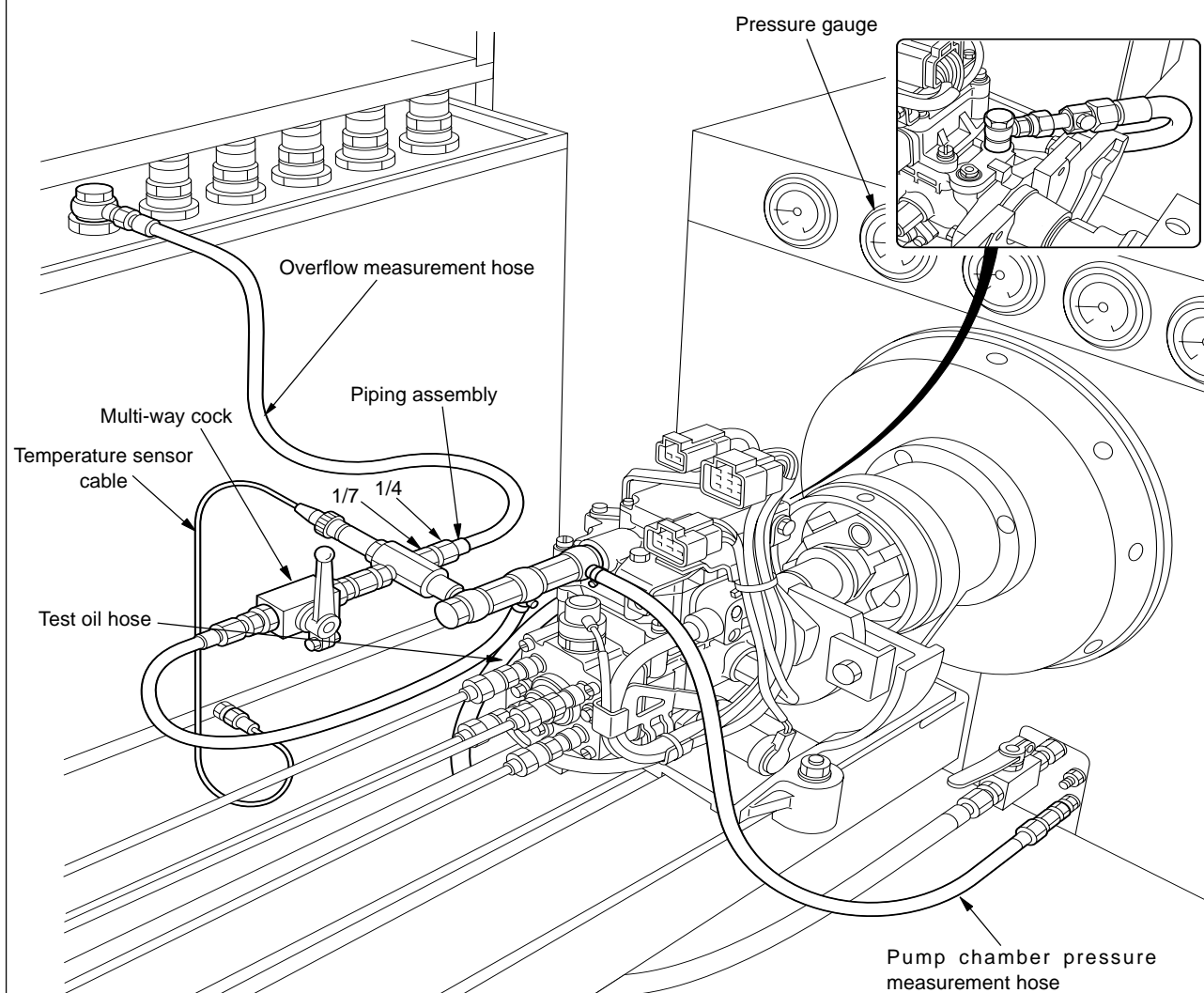

P-COVR-205

[3] Wiring outline

(1) Controller assembly wiring
MAZDA WL ENGINES

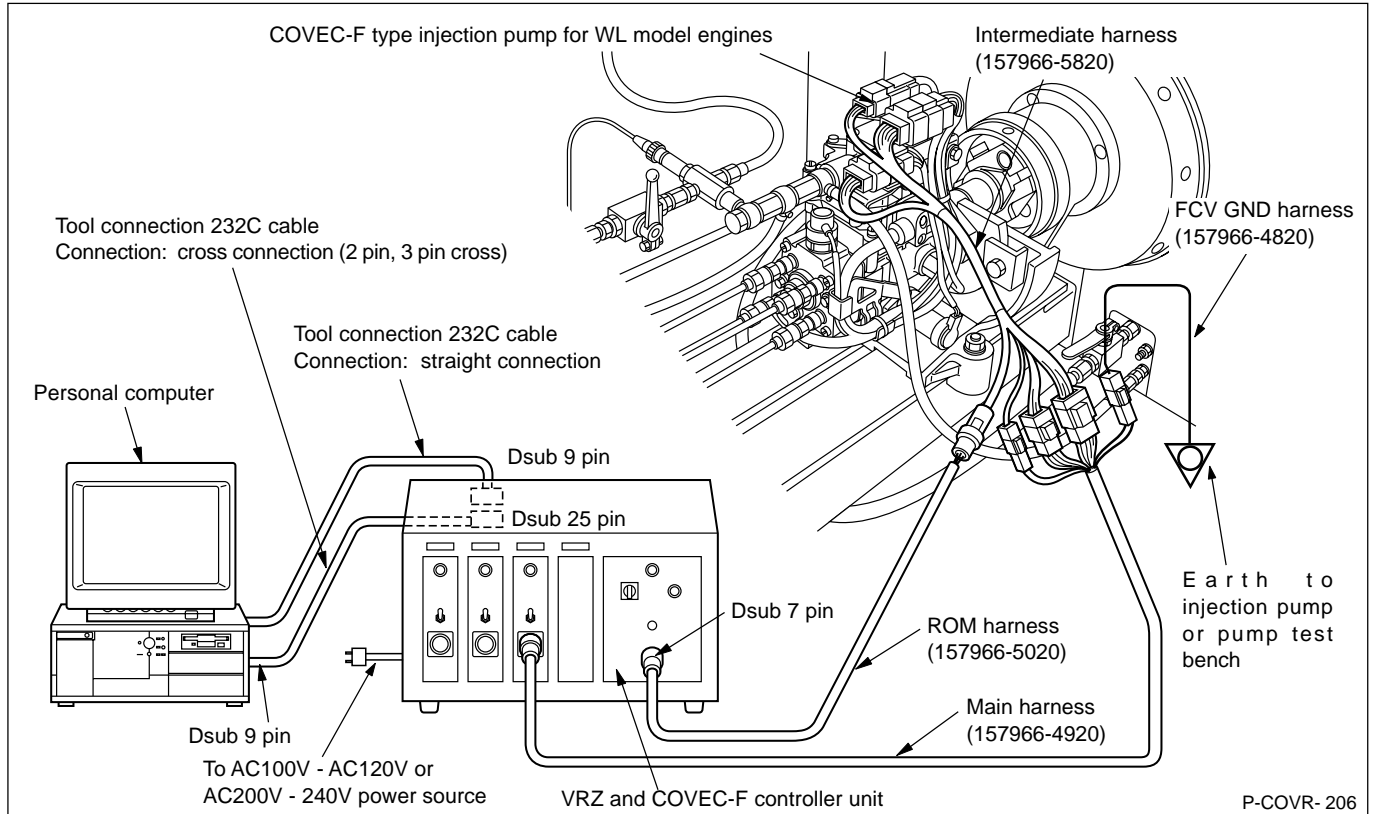

MITSUBISHI 4D56 ENGINES

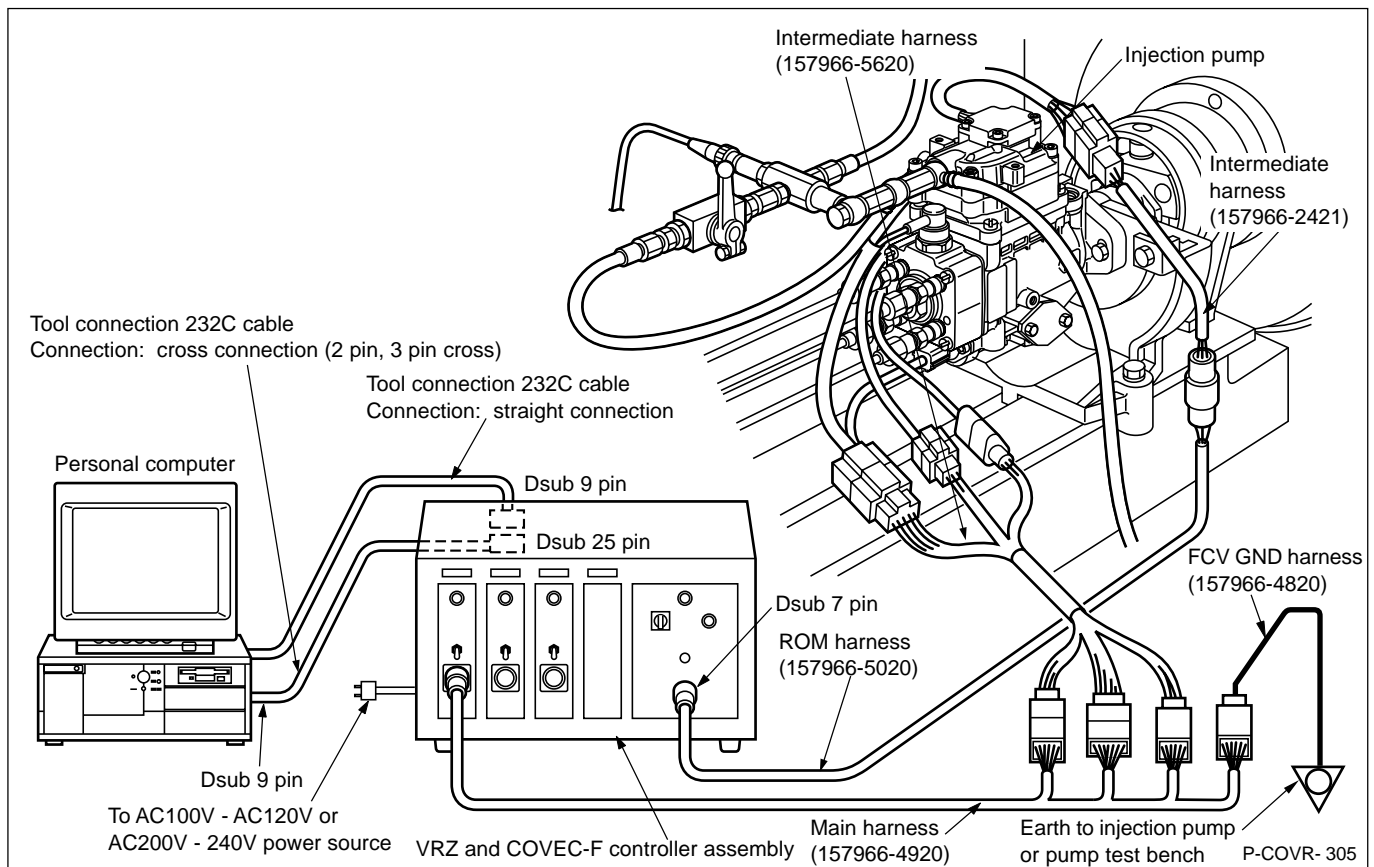

4 ADJUSTMENT

(2) Wiring connections inside controller unit

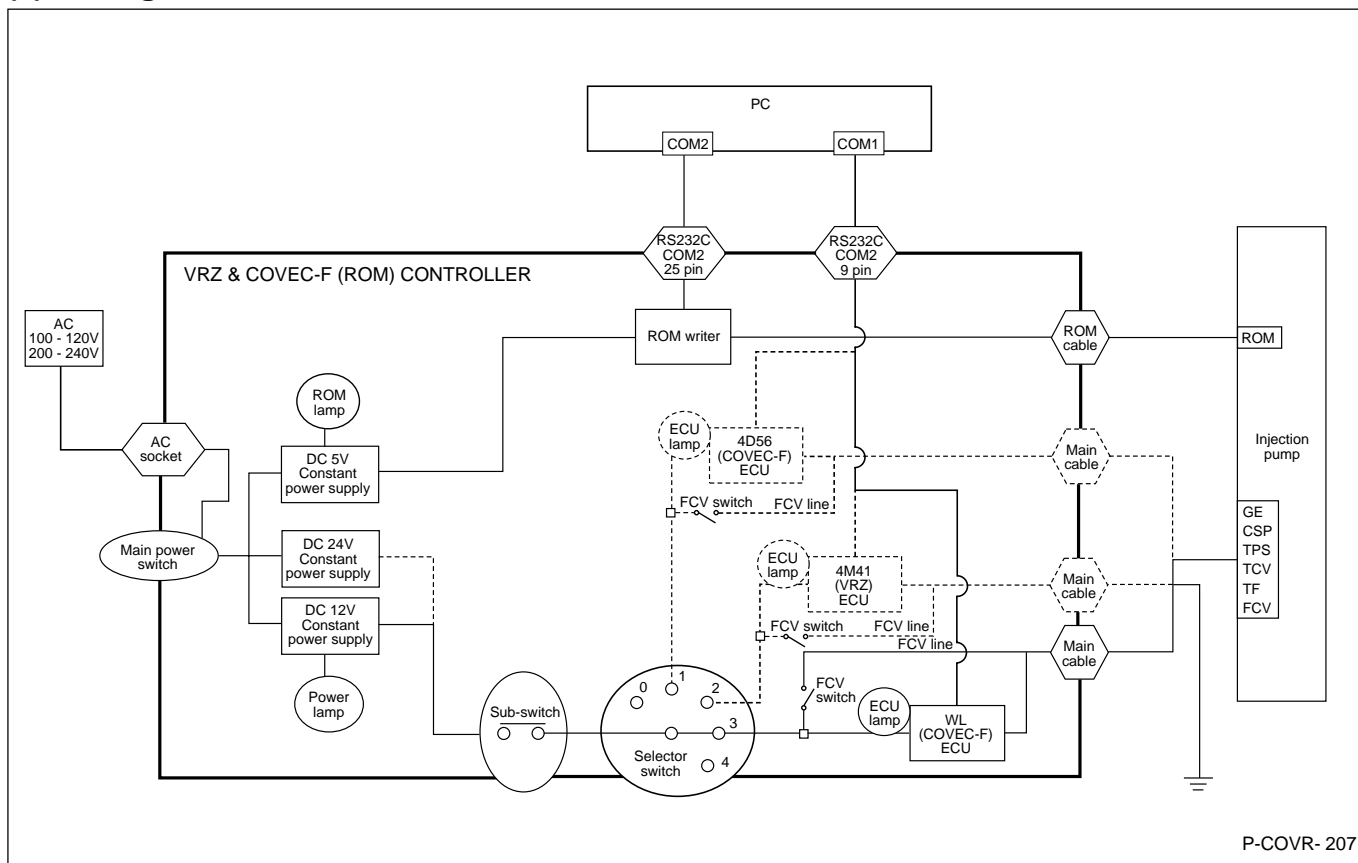

Note:

The above figure shows the wiring connections for the controller unit when used for the Mazda WL engine.

[4] Related materials

No.	Publication No.	Remarks
1	ED14E-11020	When installing the ECU assembly for the controller unit, refer to the installation instructions included with the controller unit.
2	ED14E-11010	When installing the adjustment software, refer to the installation manual included with the CD-ROM.

Note:

Where updating of adjustment data and inspection data is indicated, copy the data from the ESPI (ZW)'s CD-ROM.

2. CONTROLLER UNIT CONTROLS

[1] Front panel

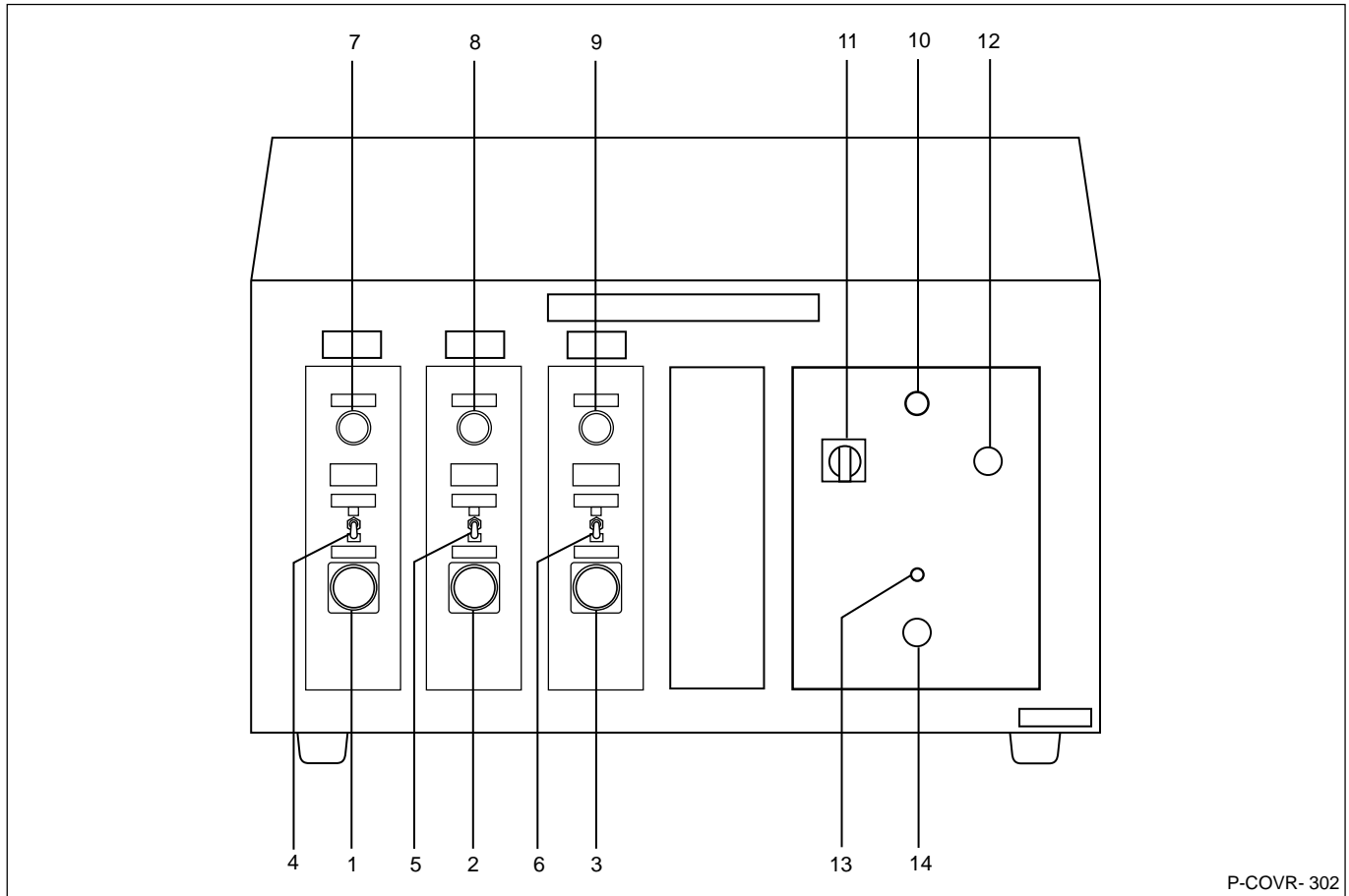

P-COVR- 302

Key no	Name	Use and purpose
1	Pump side wire harness connection	For connecting harness for injection pump's harness connectors and GE controller.
2	Pump side wire harness connection	For connecting harness for injection pump's harness connectors and GE controller.
3	Pump side wire harness connection	For connecting harness for injection pump's harness connectors and GE controller.
4	FCV (magnet valve) ON / OFF switch	Turns the FCV (magnet valve) ON and OFF. Turned ON when in use (positioned up). Usually turned OFF (positioned down).
5	FCV (magnet valve) ON / OFF switch	Turns the FCV (magnet valve) ON and OFF. Turned ON when in use (positioned up). Usually turned OFF (positioned down).
6	FCV (magnet valve) ON / OFF switch	Turns the FCV (magnet valve) ON and OFF. Turned ON when in use (positioned up). Usually turned OFF (positioned down).
7	4D56 ECU pilot lamp	Orange lamp lights when 4D56 ECU in use.
8	4M41 ECU pilot lamp	Orange lamp lights when 4M41 ECU in use.
9	WL ECU pilot lamp	Orange lamp lights when WL ECU in use.
10	Power pilot lamp	Orange lamp lights when ECU in use (when breaker is turned ON).

4 ADJUSTMENT

Key no	Name	Use and purpose
11	ECU changeover switch	Turn to align with ECU in use. 0: All OFF 1: No. 1 ECU 2: No. 2 ECU 3: No. 3 ECU 4: Spare ECU
12	Sub-switch	Power sub-switch for controller unit for COVEC-F adjustment. Press once to turn ON. When turned ON for use, orange lamp lights. Press once again to turn OFF.
13	ROM pilot lamp	Green lamp lights when ROM in use.
14	ROM wire harness connecting terminal	For connecting injection pump's ROM harness connector to ROM controller using wire harness.

CAUTION

If you smell any unusual smell or see smoke or sparks when using the controller unit, turn the power switch OFF immediately and stop using the controller unit.

Fire may result if you continue to use the controller unit.

Advice

- **Do not use the controller unit with oily hands. The oil may stick to the dials and cause improper resistor contact inside the controller unit, preventing proper operation.**
- **Before turning the power switch ON, confirm that the wire harnesses are properly connected.**

[2] Rear panel

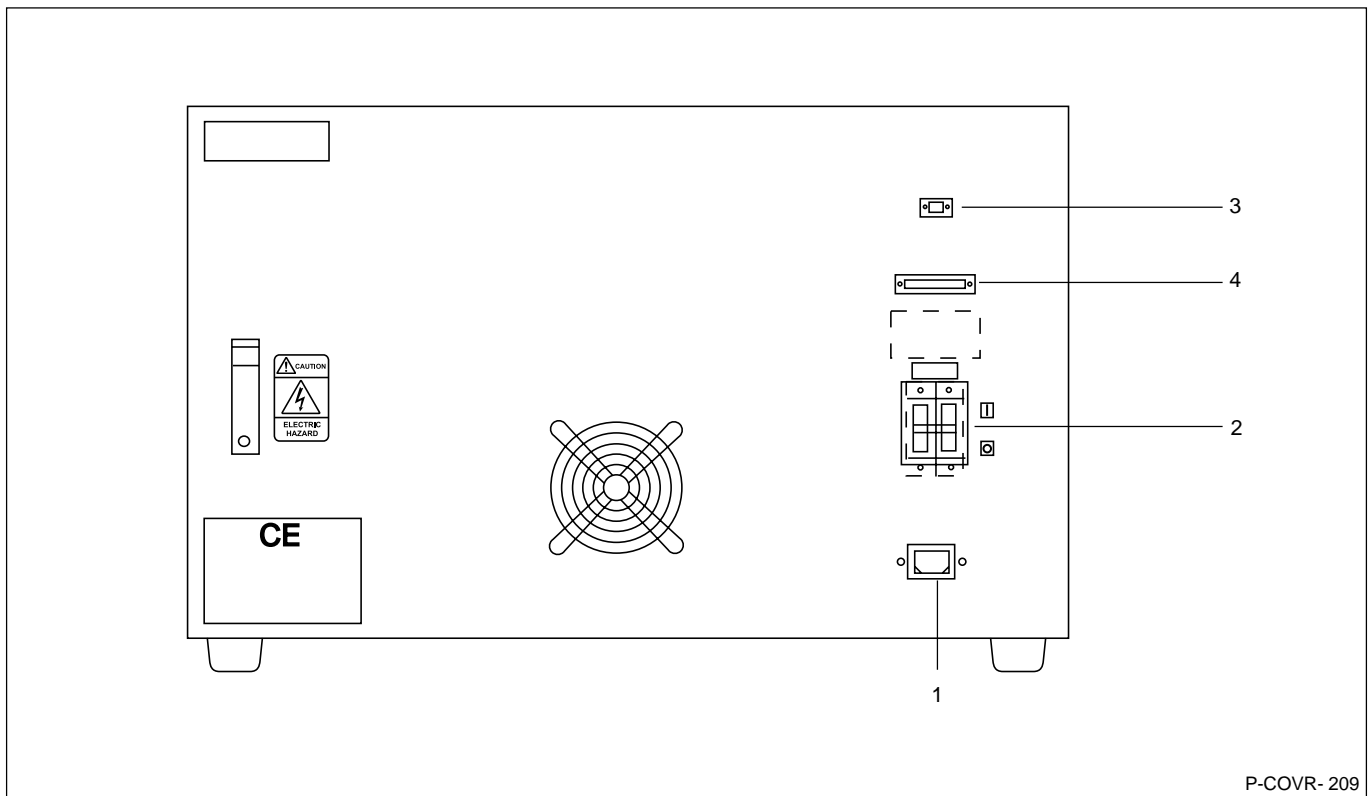

P-COVR- 209

Key no	Name	Use and purpose
1	AC100V - 120V power or AC 200V - 240V power terminal	Connect to AC100V - 120V, 50Hz / 60Hz power or AC 200V - 240V, 50Hz / 60Hz power source.
2	Main switch (breaker)	Controller assembly power switch. Turn ON when in use (position at 'I'). Position at 'O' to turn OFF.
3	D-sub 9 pin cable connection (COM1)	Connects RS232C cable to personal computer (for GE).
4	D-sub 25 pin cable connection (COM2)	Connects RS232C cable to personal computer (for Q-ROM).

⚠ CAUTION

If you smell any unusual smell or see smoke or sparks when using the controller unit, turn the power OFF immediately and stop using the controller unit. Fire may result if you continue to use the controller unit.

Advice

- Do not use the controller unit with oily hands. The oil may stick to the dials and cause improper resistor contact inside the controller unit, preventing proper operation.
- Before turning the power switch ON, confirm that the wire harnesses are properly connected.

3. PUMP ADJUSTMENT TOOL FLOW CHART

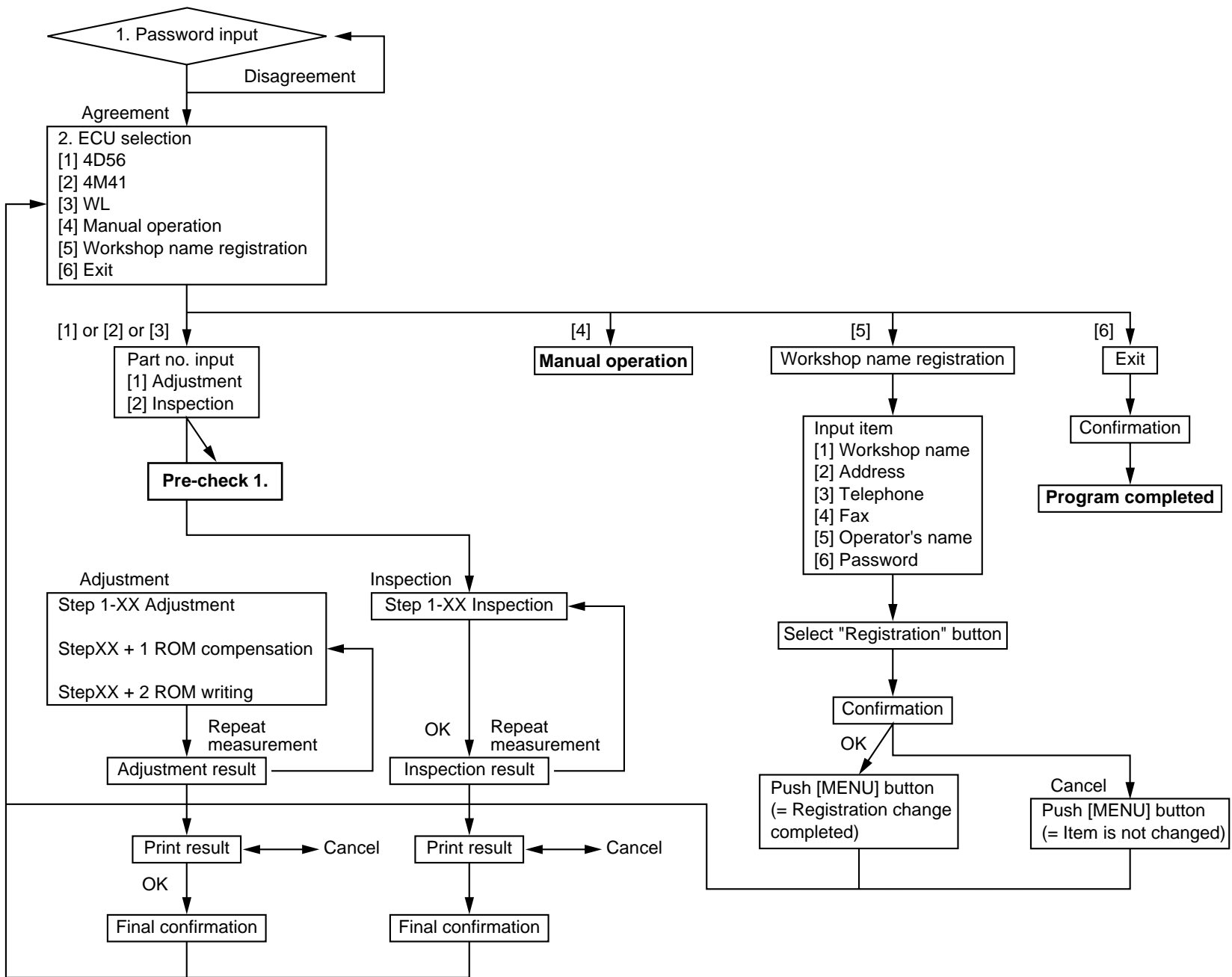

4. PUMP ADJUSTMENT TOOL MONITOR SCREEN

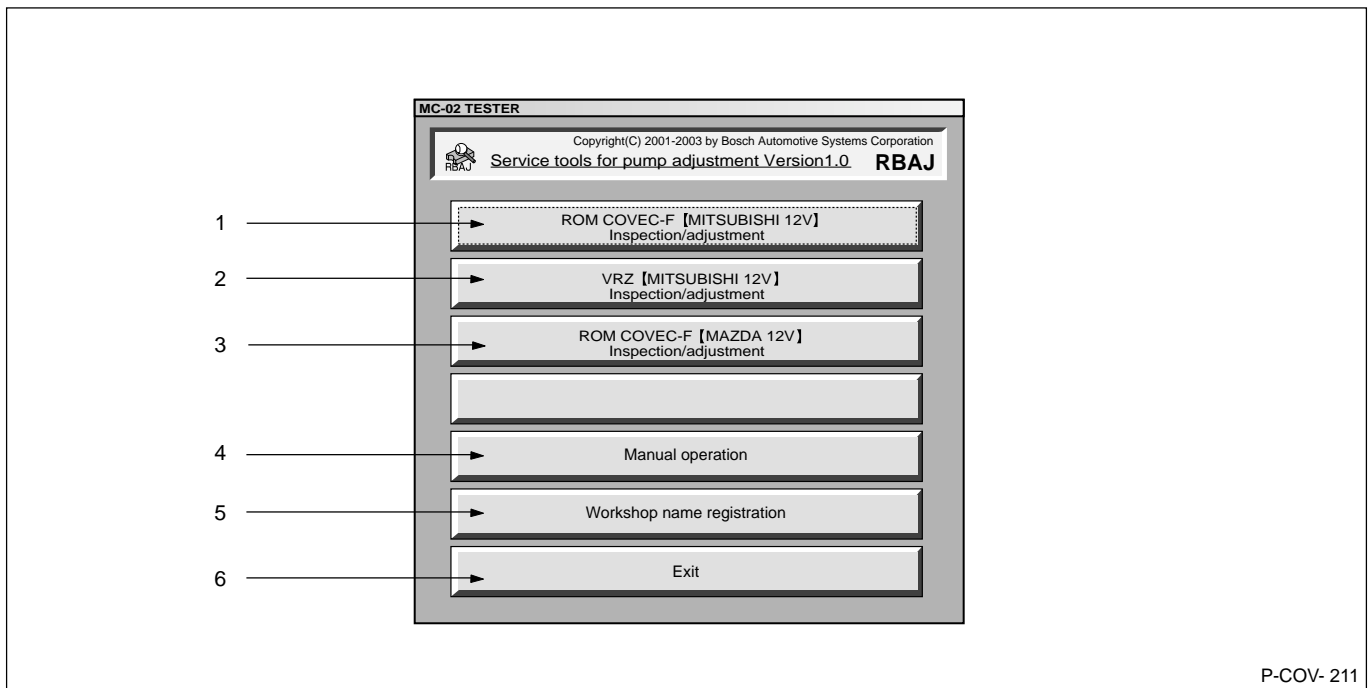

No.	Name	Use and purpose
1	4D56 model engine's COVEC-F type injection pump inspection / adjustment key	Select for inspection / adjustment of COVEC-F injection pump for Mitsubishi 4D56 model engine
2	4M41 model engine's VRZ type injection pump inspection / adjustment key	Select for inspection / adjustment of VRZ injection pump for Mitsubishi 4M41 model engine
3	WL model engine's COVEC-F type injection pump inspection / adjustment key	Select for inspection / adjustment of COVEC-F injection pump for Mazda WL model engine
4	Pre-stroke adjustment key	For adjusting injection pump's pre-stroke
5	Workshop registration key	For workshop registration
6	Exit key	To exit adjustment software

4 ADJUSTMENT

5. PUMP ADJUSTMENT TOOL MONITOR SCREEN OUTLINE Inspection and adjustment step screen

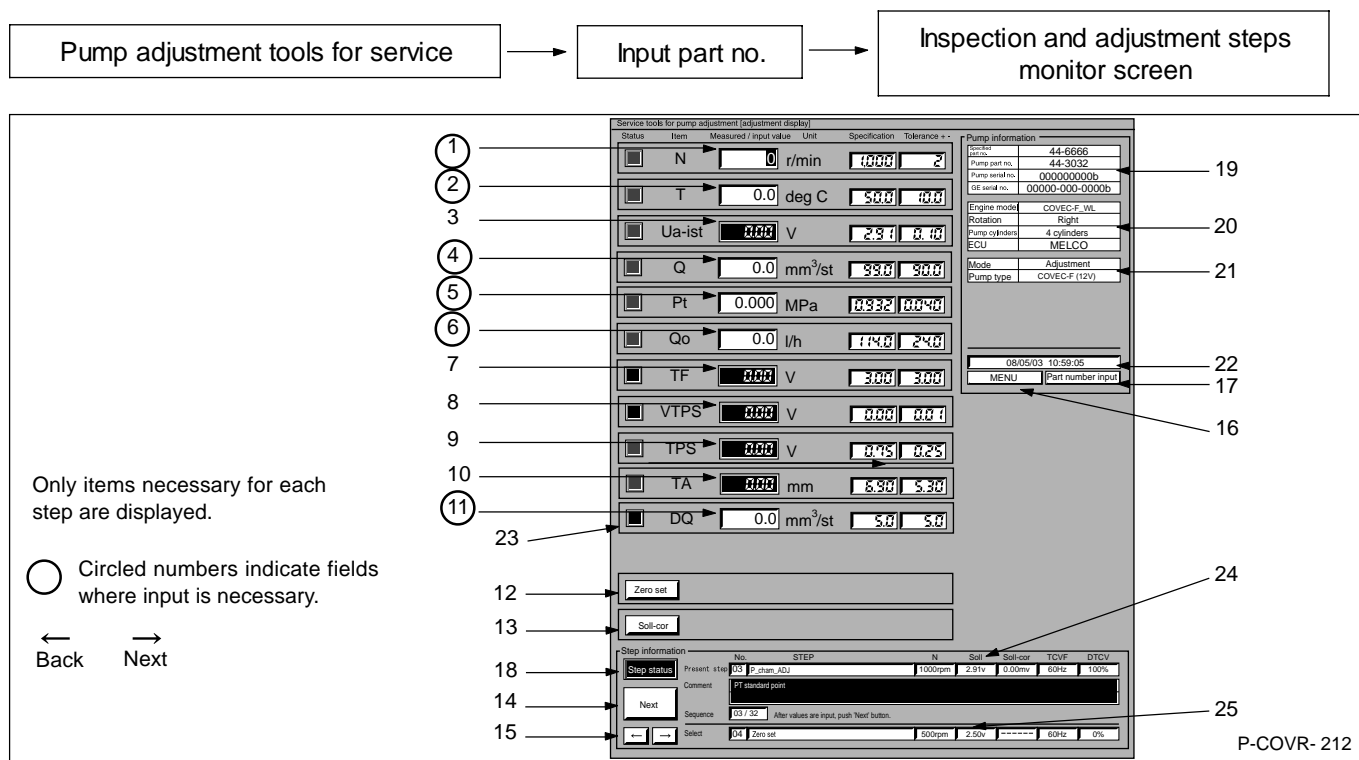

No.	Name	Remarks
1	Pump speed input (N)	Input the pump's speed.
2	Test oil temperature input (T)	Input the test oil temperature.
3	Actual control sleeve position voltage display (U α soll)	Displays actual control sleeve position voltage.
4	Pump injection quantity input	Input pump's injection quantity.
5	Pump chamber pressure input	Input pump's chamber pressure.
6	Pump overflow quantity input	Input pump's overflow quantity.
7	Fuel temperature (TF) output voltage display	Displays fuel temperature output voltage.
8	Output voltage display (VTPS) at 0 mm timer stroke	Displays VTPS output voltage (voltage at 0 mm timer stroke).
9	Timer piston sensor voltage output display (TPS)	Displays TPS (timer piston sensor output voltage).
10	Timer stroke output display (TA)	Displays TA (timer stroke) output.
11	Input of variation between cylinders (DQ)	Input variations between pump's injection quantities.
12	Zero setting key	TPS output voltage at TA = 0 mm can be set at 0 V.
13	Target control sleeve position compensation voltage display	Any control sleeve position can be set by setting the compensation voltage.
14	NEXT key	To set at next step.
15	Keys for moving to next or previous step	To set at any step (← BACK, → NEXT).
16	Menu key	To set at MENU display.
17	Part number input key	To set at part number input display.
18	Step status key	Displays step status. Changes from red to green when all items are within specifications.
19	Part number, serial number display	Displays pump information part number (specification, pump) and serial number (pump, GE).
20	Specification display	Displays pump information specifications.
21	Measurement mode display	Displays pump information measurement mode (inspection, adjustment).
22	Measurement date display	Displays date and time of measurements.
23	Status display	Displays step status. Green: within specifications; red: outside of specifications.
24	Current step display	Displays current step items.
25	Next step display	Displays next step's items.

6. MANUAL OPERATION DISPLAY

Pre-stroke adjustment (manual operation)

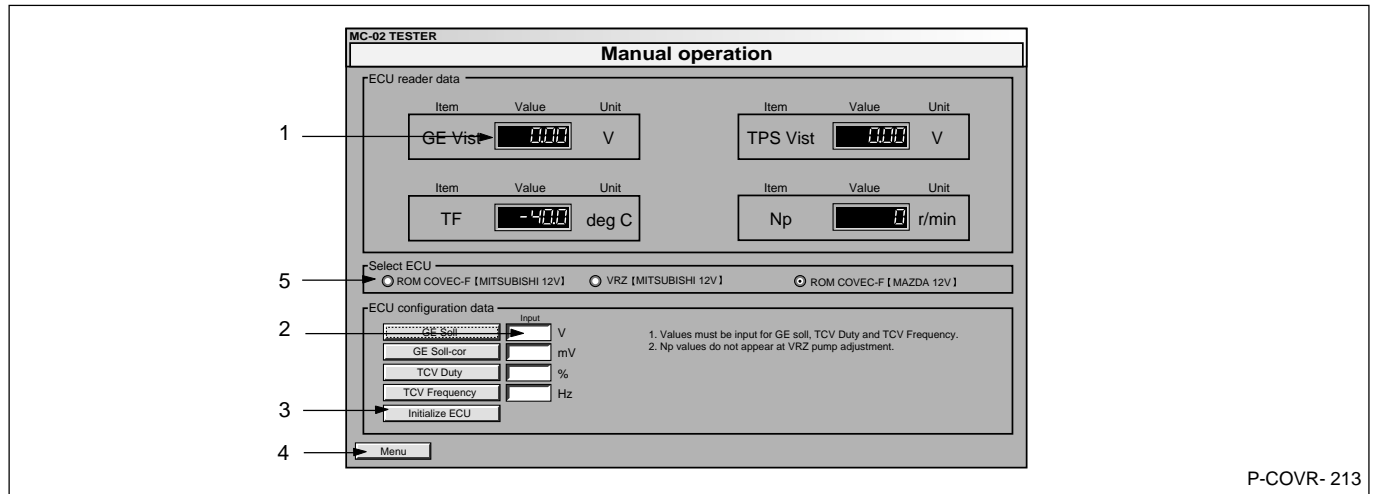

P-COVR- 213

No.	Name	Remarks
1	Control sleeve position actual voltage display	Displays actual control sleeve position voltage.
2	Control sleeve position target voltage input	By operating the input keys, the control sleeve position can be set for the engine specified in No. 5.
3	Initialize ECU	Clears display values.
4	MENU	Displays MENU screen.
5	Select ECU	Select the ECU for the engine.

7. WORKSHOP DISPLAY

Second timing adjustment (manual operation)

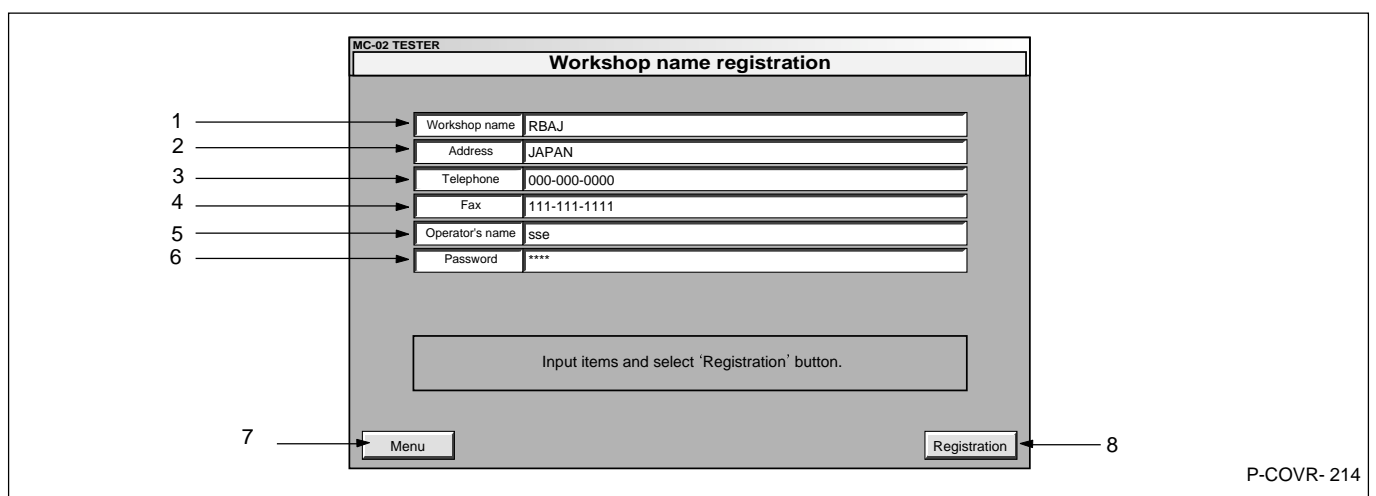
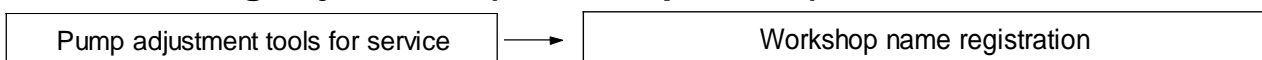

P-COVR- 214

4 ADJUSTMENT

No.	Name	Remarks
1	Workshop name	Input company name.
2	Address	Input company address.
3	Telephone	Input telephone number.
4	Fax	Input fax number.
5	Operator's name	Input operator's name.
6	Password	Input password and change password.
7	MENU	Can be used to set MENU display.
8	Registration	For keeping registered items.

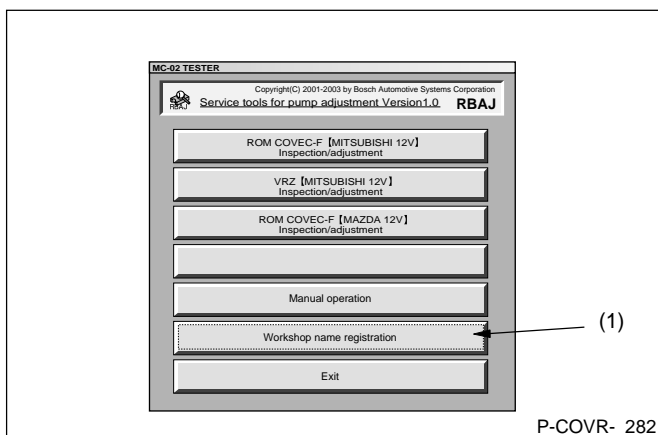

WORKSHOP REGISTRATION

(1) Select 'Workshop name registration.'

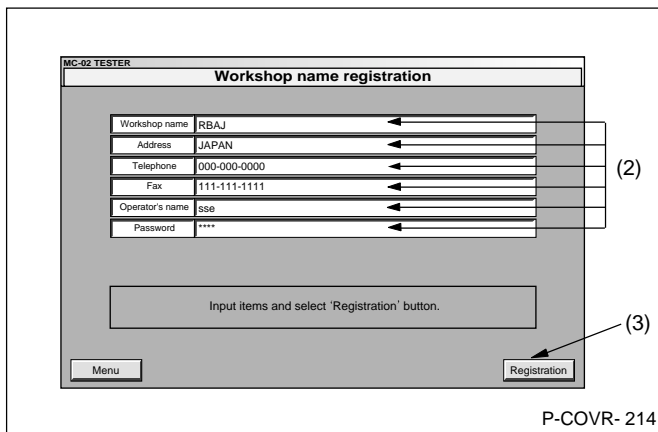

(2) Input the company name, etc, in the fields on the screen.

(3) Click the 'Registration' button.

Note:

The default password at setup is 'RBAJ'. Input a new password if desired. (The only limit to the number of figures and letters in the password is the size of the input field.)

8. ADJUSTMENT

Adjustment sequence

Note:

The following describes adjustment of the COVEC-F pump for Mazda WL engines.

For Mitsubishi 4D56 engines, the adjustment sequence, the wiring harnesses and connections, and the ECU assembly used differ from those of Mazda engines.

The details of the adjustment procedures, however are the same. Refer to page 11 for the wiring outline for Mitsubishi 4D56 engines.

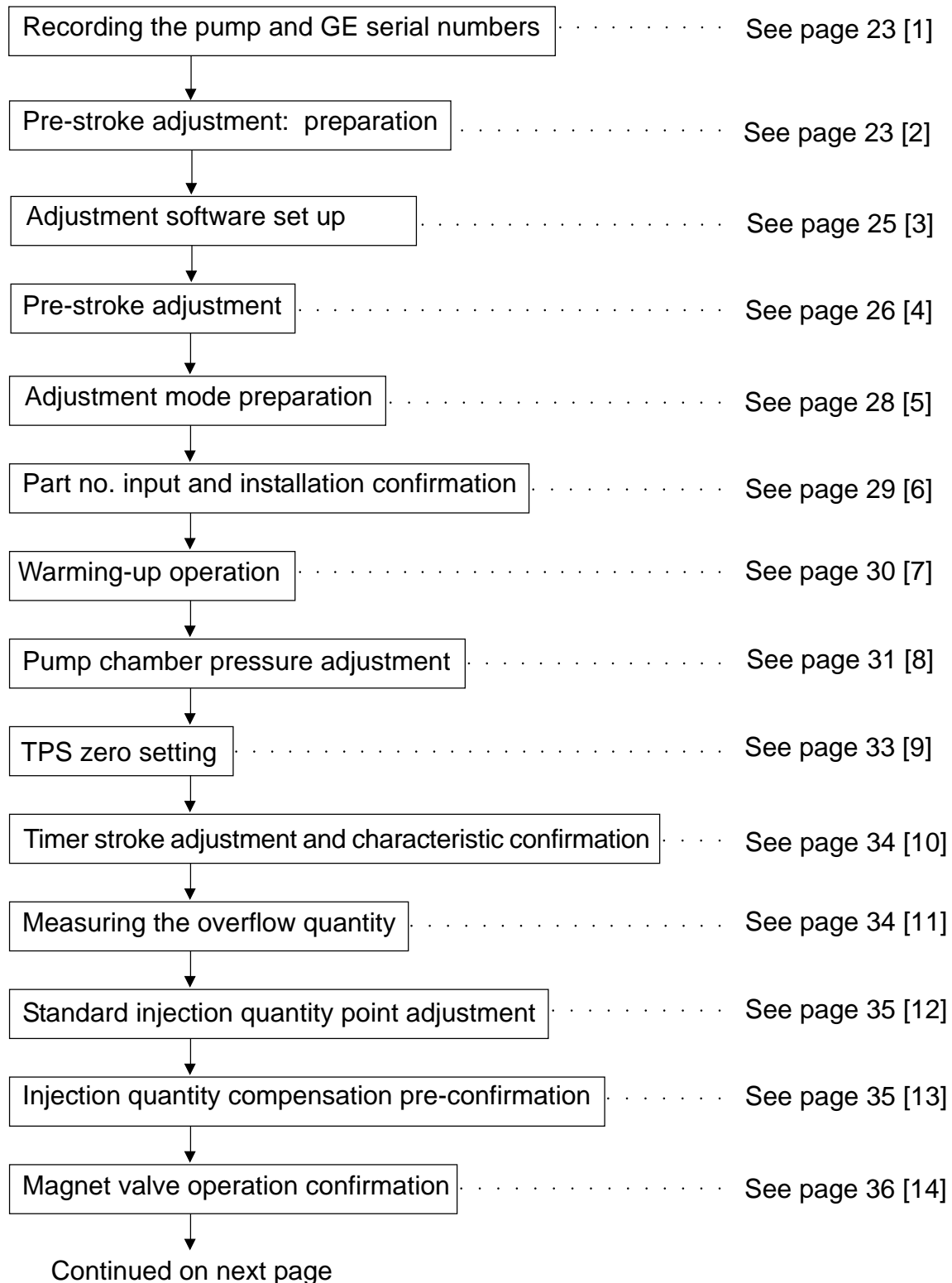

4 ADJUSTMENT

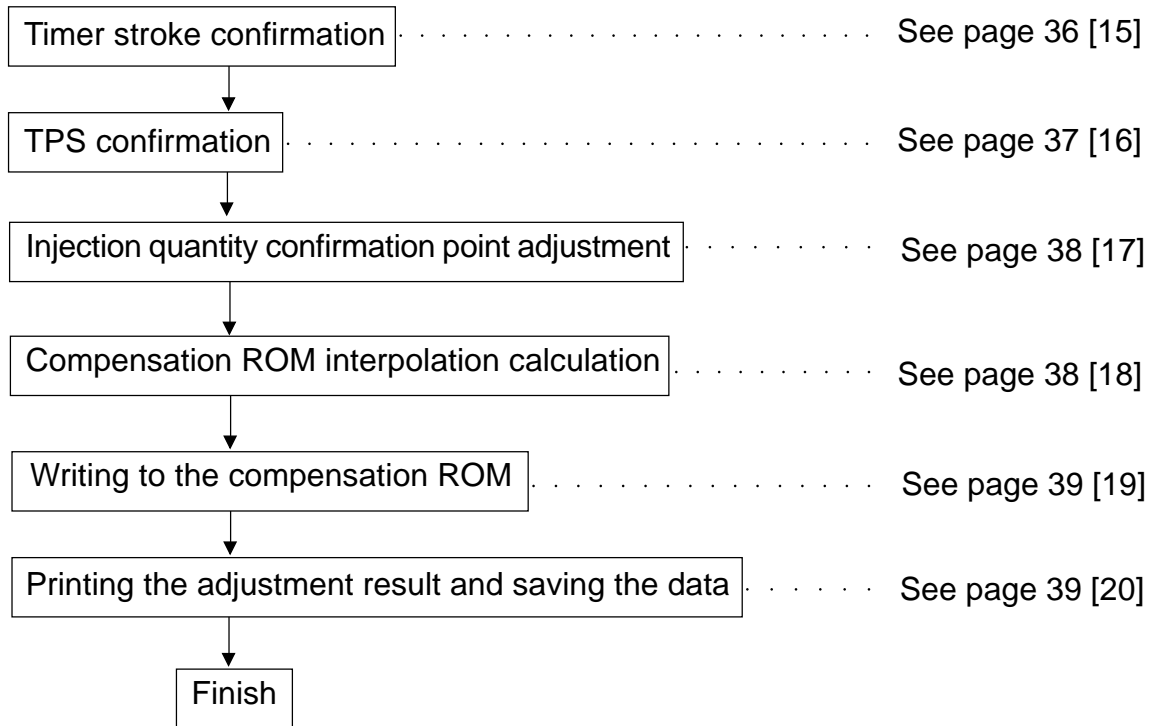

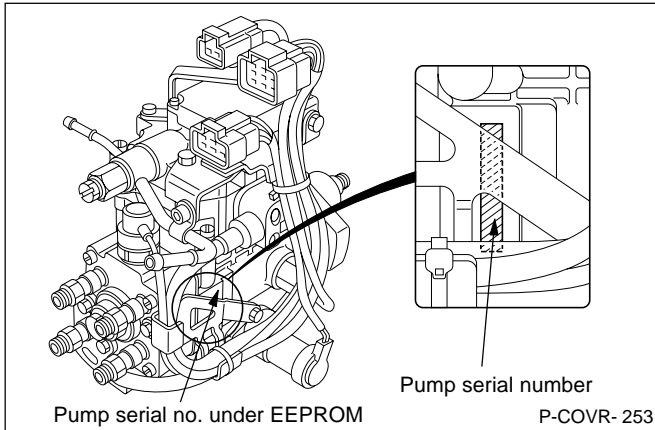

[1] Recording the pump and GE serial numbers

- (1) Read and record the 10 digit pump serial number.

Advice

It is easier to read the pump's serial number before beginning 'Preparation.'

Note:

Serial number input is used during adjustment mode and inspection mode.

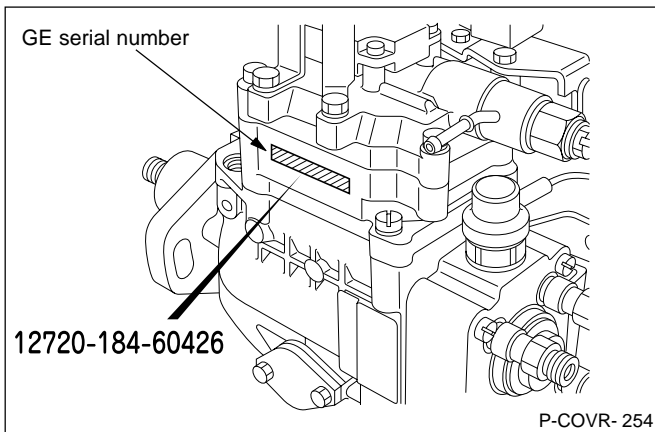

- (2) Read and record the 13 digit GE actuator serial number.

Advice

It is easier to read the GE actuator's serial number before beginning 'Preparation.'

Note:

Serial number input is used during adjustment mode and inspection mode.

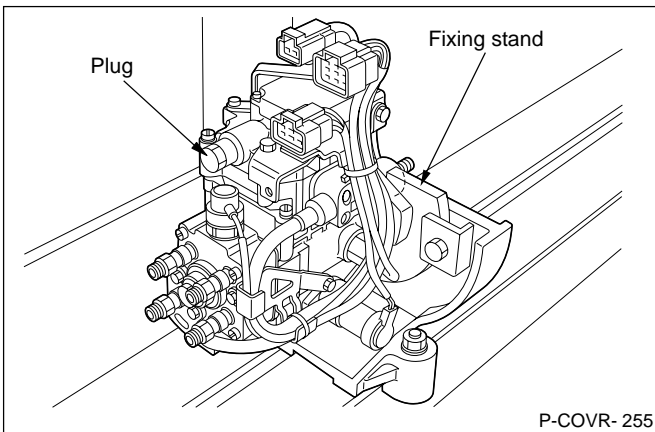

[2] Pre-stroke adjustment: preparation

- (1) Temporarily attach the fixing stand to the pump test bench and attach the injection pump to the fixing stand.

Tool name	Part no.	Remarks
Fixing stand	105796-0000	

- (2) Attach the plug to where the overflow valve was removed.

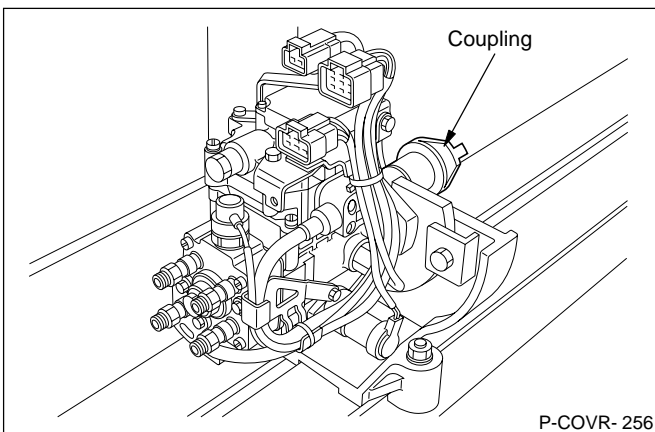

- (3) Assemble the key to the drive shaft.
- (4) Align the coupling with the key, assemble it to the shaft and fix it using the nut.

Tool name	Part no.	Remarks
Coupling	105842-4522	

4 ADJUSTMENT

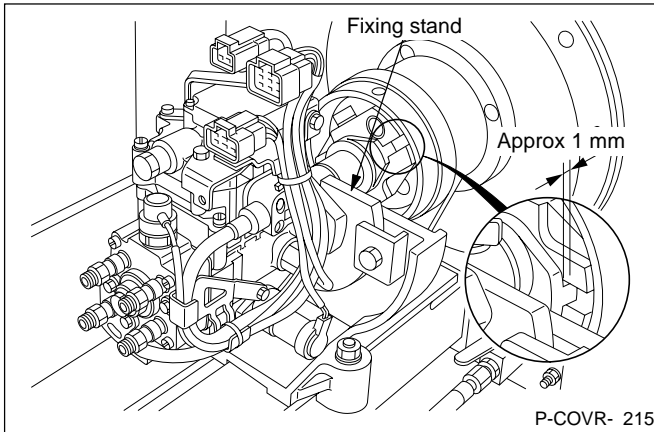

- (5) Move the fixing stand and assemble the coupling teeth to the pump test bench drive coupling. Ensure approximately 1 mm clearance between the coupling and the drive coupling.

Advice

The clearance between the coupling and the drive coupling must not exceed 1 mm.

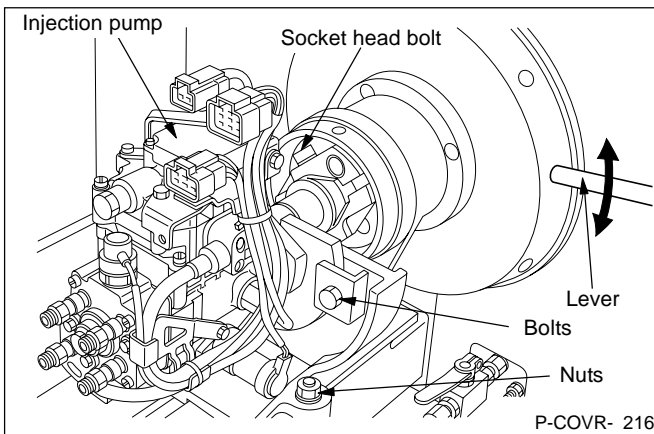

- (6) Rotate the pump test bench flywheel using the lever and confirm that the injection pump rotates smoothly.
- (7) Securely tighten the fixing stand installation bolts and nuts and the drive coupling socket head bolt to fix the injection pump to the pump test bench.

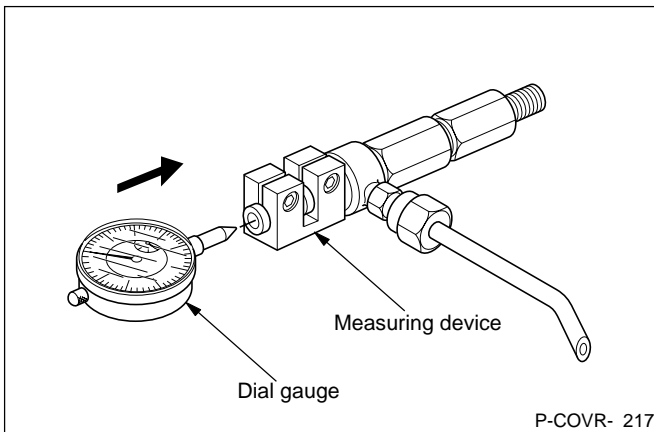

- (8) Attach the dial gauge to the measuring device.

Tool name	Part no.	Remarks
Dial gauge	157954-4100	
Measuring device	105782-8160	

Advice

Confirm that the gauge needle moves smoothly.

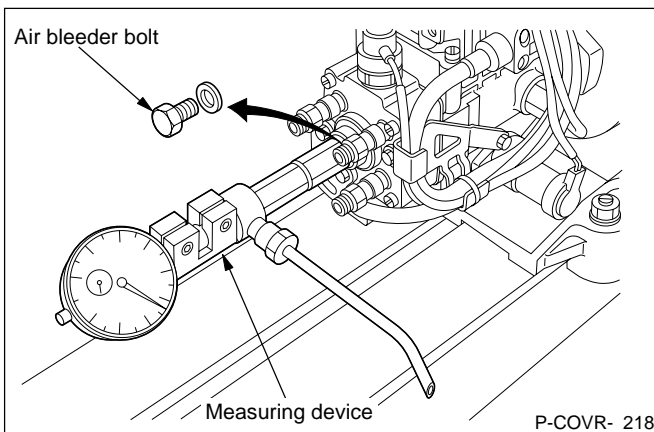

- (9) Remove the air bleeder bolt.
- (10) Install the measuring device to where the air bleeder bolt was installed.

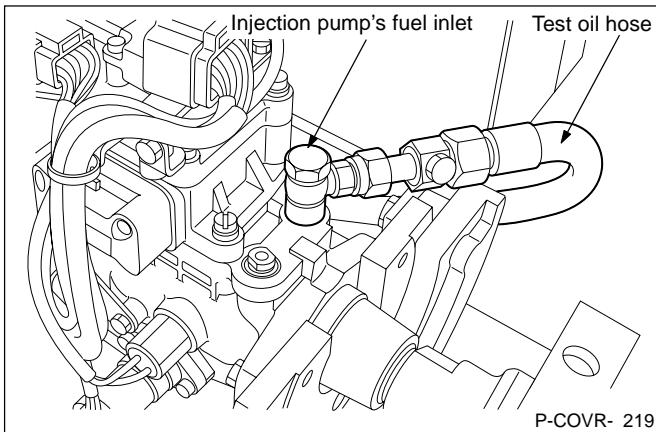

- (11) Connect the test oil hose to the injection pump's fuel inlet.

Advice

Do not connect the pump chamber pressure measurement hose, the overflow measurement hose, the temperature sensor cable or the multiway cock.

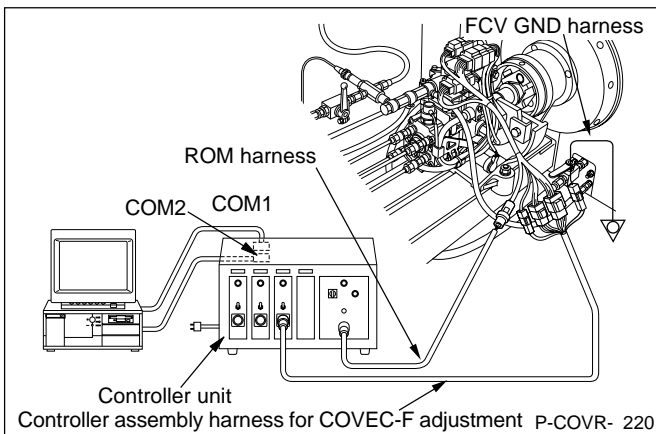

- (12) Connect the controller assembly's wire harness and intermediate harness to the injection pump's connectors. (Refer to page 11 for the controller assembly's wiring. The following describes Mazda wiring.)
- (13) Connect the wire harness to the controller unit's ECU assembly connector (Mazda: No. 3; Mitsubishi: No. 1).
- (14) Connect the ROM controller's wire harness to the intermediate harness.
- (15) Connect the FCV GND harness to the controller assembly's wire harness and to earth.
- (16) Connect the D-Sub 9 pin cable connector (COM 1) on the rear of the controller unit to the personal computer using the wire harness.
- (17) Connect the D-Sub 25 pin cable connector (COM 2) on the rear of the controller unit to the personal computer using the wire harness.

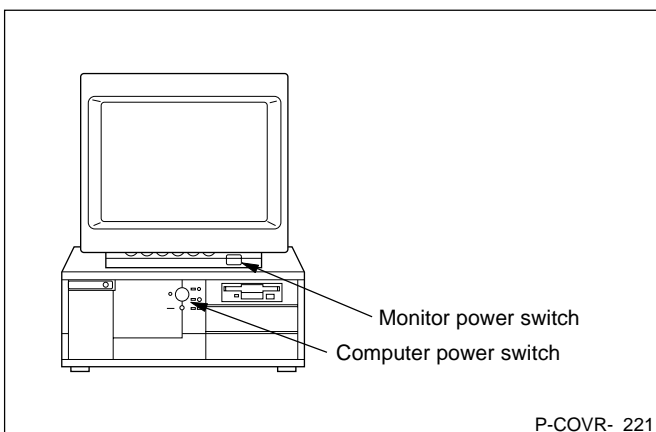

[3] Adjustment software set up

- (1) Turn the computer and the monitor power switches ON.

4 ADJUSTMENT

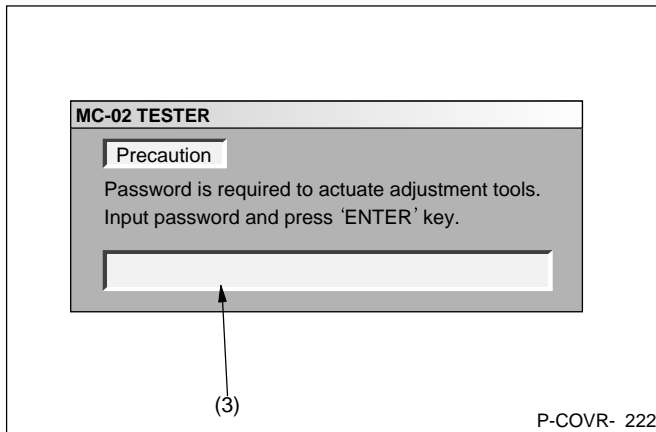

(2) Start the 'Service tools for pump adjustment' software.

(3) Input the password and press the 'Enter' key.

Advice

Input the initial default password ('RBAJ') or your own password.

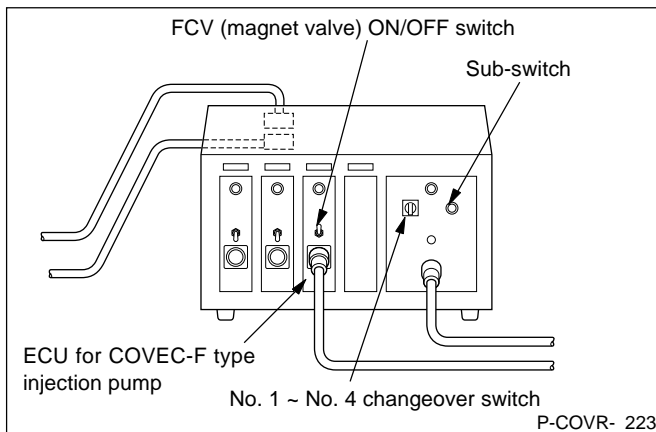

(4) Turn the main switch on the rear of the controller unit ON.

(5) Set the No 1 ~ No 4 changeover switch at the relevant setting (Mazda: No. 3; Mitsubishi: No. 1).

(6) Turn the FCV (magnet valve) ON/OFF switch ON to energize the magnet valve.

(7) Turn the sub-switch on the front of the controller unit ON.

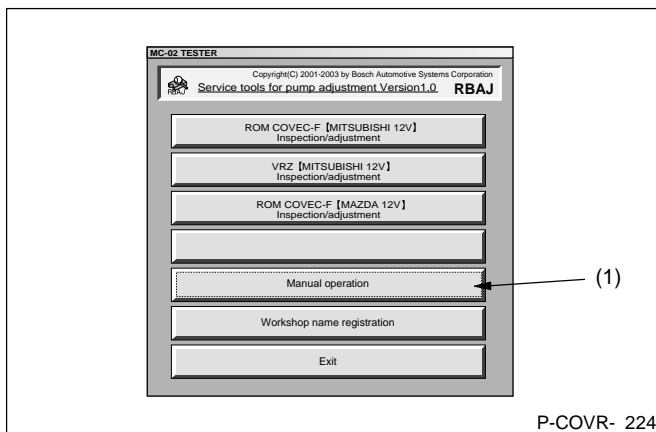

[4] Pre-stroke adjustment

(1) Select the 'Manual operation' button.

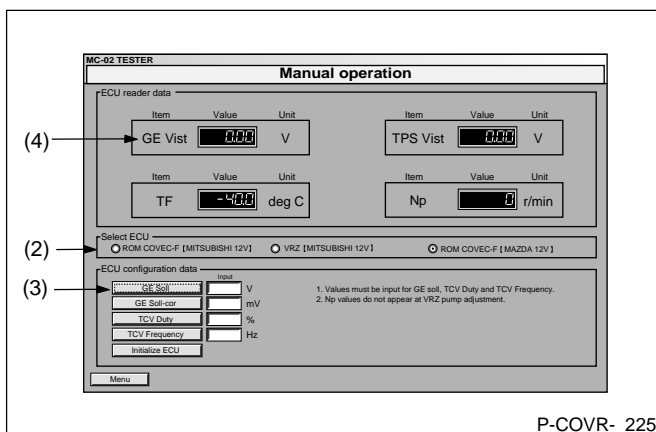

(2) Select the ECU.

(3) Click the 'GE soll' key and input the specified GE soll voltage value 2.8 V.

(4) Confirm that the GE Vist value is displayed.

Note:

The GE Vist values vary.

4 ADJUSTMENT

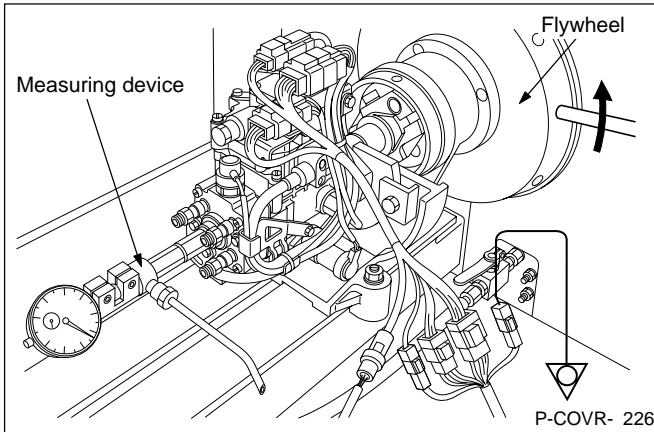

- (5) Supply test oil to the injection pump at the specified supply pressure (20 kPa {0.2 kgf/cm²}).
- (6) Rotate the pump test bench's flywheel 1 ~ 2 turns in the specified direction of rotation using the lever and confirm from the dial gauge that the plunger lifts smoothly.

Advice

Test oil will flow from the measuring device's spill pipe. Prepare a container.

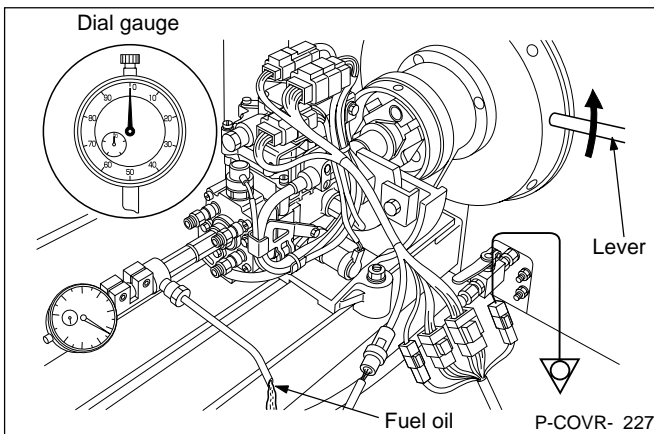

- (7) Rotate the pump test bench's flywheel in the specified direction to position the plunger in the bottom dead center position.

Note:

The plunger's bottom dead center position is the smallest reading indicated by the dial gauge needle.

- (8) Zero the dial gauge.

Advice

Test oil will flow from the measuring device's spill pipe. Prepare a container.

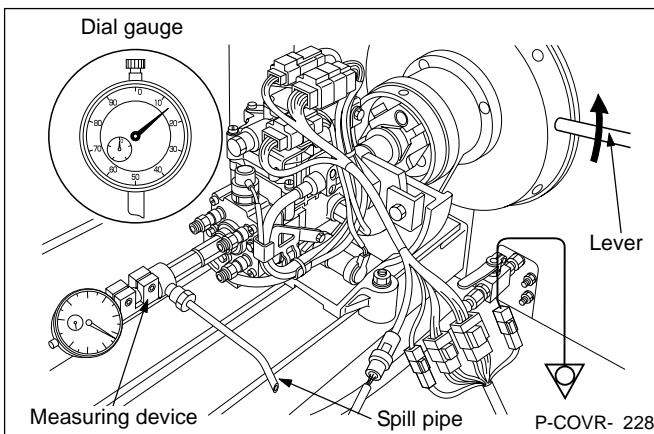

- (9) Slowly rotate the pump test bench's flywheel in the specified direction of rotation using the lever. Read the dial gauge indication (ie, the pre-stroke) when test oil stops flowing from the measuring device's spill pipe.

⚠ CAUTION

Remove the lever after operating the flywheel.

Operating the pump test bench with the lever in place can result in bodily injury or pump test bench damage.

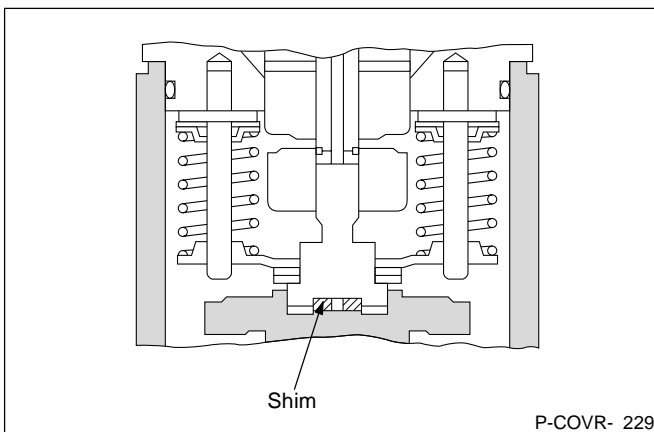

- (10) If pre-stroke is not as specified, replace the shim to adjust the 'K' dimension. (Refer to the COVEC-F Service Manual, Publication No. EE14E-11102, pages 40 to 42 for 'K' dimension measurement.)

4 ADJUSTMENT

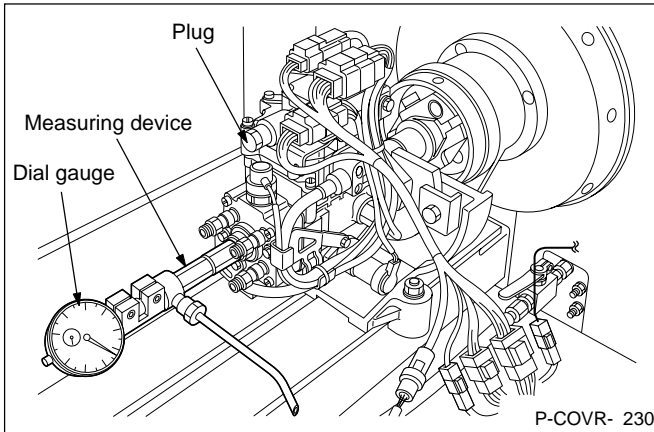

[5] Adjustment mode preparation

- (1) Remove the dial gauge and the measuring device.
- (2) Remove the plug.

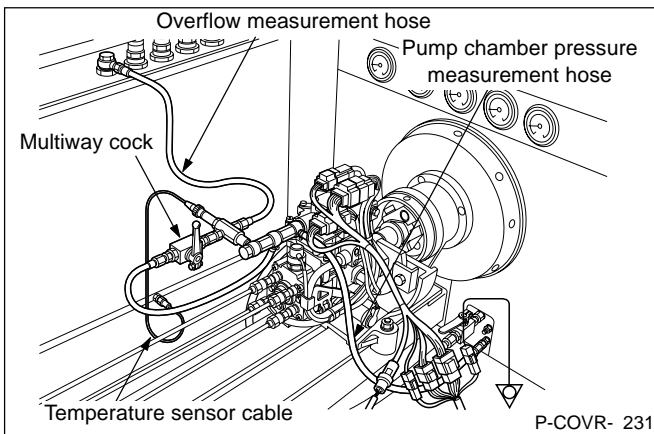

- (3) Connect the pump chamber pressure measurement hose, the overflow measurement hose, the temperature sensor cable, and the multiway cock to the injection pump. (Refer to page 10 for the fuel piping.)
- (4) Connect the injection system piping to the injection pump. (Refer to page 9 for the injection system piping.)

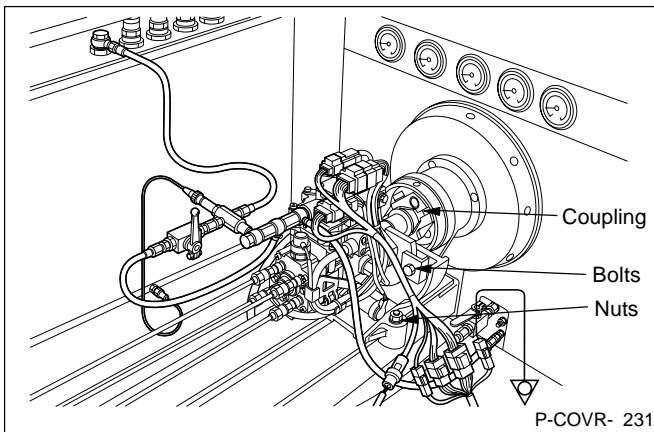

- (5) Reconfirm that the coupling and the fixing stand bolts and nuts are securely tightened.
- (6) Attach the measuring device to the injection pump. (The measuring device cannot be seen in the figure at left.)

Tool name	Part no.	Remarks
Measuring device	105782-8260	

- (7) Set the 20NP pump test bench test oil overflow temperature at 45°C.

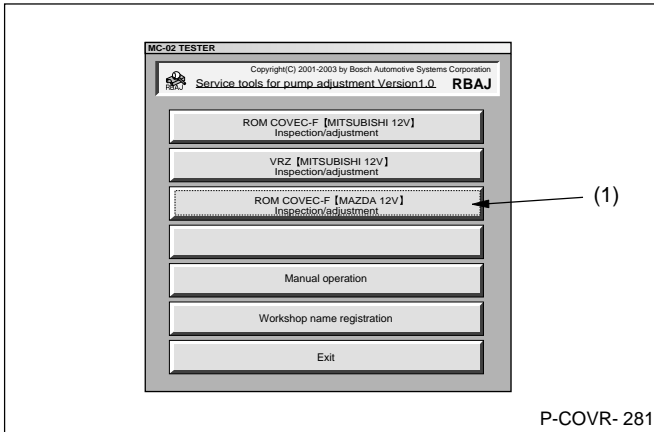

P-COVR- 281

[6] Part number input and installation confirmation

- (1) Select the Inspection/adjustment button (Mazda: 'ROM COVEEC-F [MAZDA 12V] Inspection/adjustment'; Mitsubishi: 'ROM COVEEC-F [MITSUBISHI 12V] Inspection/adjustment').

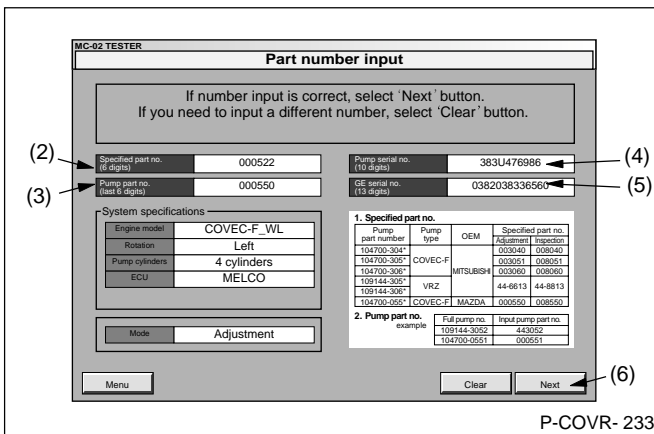

P-COVR- 233

- (2) When the dialog shown at left appears, input the specified part number (6 digits).
- (3) Input the pump part number (last 6 digits).
- (4) Input the pump serial number (10 digits).
- (5) Input the GE's serial number (13 digits).
- (6) Press the 'Next' key.

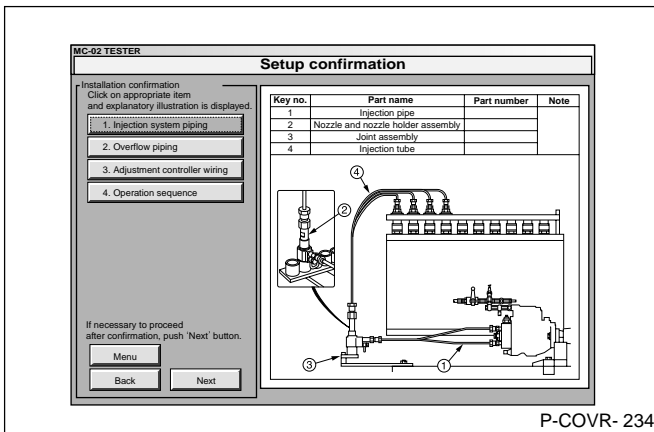

P-COVR- 234

- (7) Confirm that the screen changes to the injection system piping display.
- (8) Select '1. Injection system piping.'

Note:

Clicking the different buttons (1. Injection system piping, 2. Overflow piping, 3. Adjustment controller wiring, and 4. Operation sequence) displays different Setup confirmation screens.

4 ADJUSTMENT

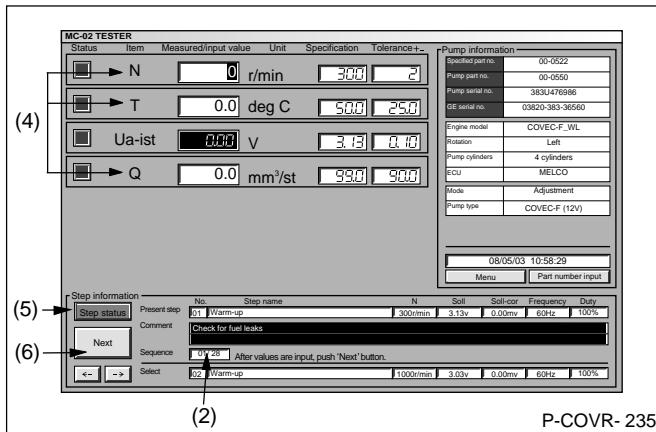

[7] Warming-up operation

- (1) Set the pump test bench delivery pressure at the specified 20 kPa {0.2 kgf/cm²}.
- (2) Confirm that the sequence is 01/28.
- (3) Run the injection pump at the specified speed N (see figure at left).
- (4) Measure N, T and Q on the pump test bench and input the values.

Note:

U α ist is displayed automatically.

- (5) Confirm that the Step status field is green.
- (6) Proceed to the next step.

Advice

- If U α ist values are not as specified, press the 'Next' button several times. Then, return to Step 01/28 using the back arrow.

Repeat the Step 01/28 and confirm that U α ist values are as specified.

Note:

If not as specified after confirming U α ist several times, the GE may be faulty.

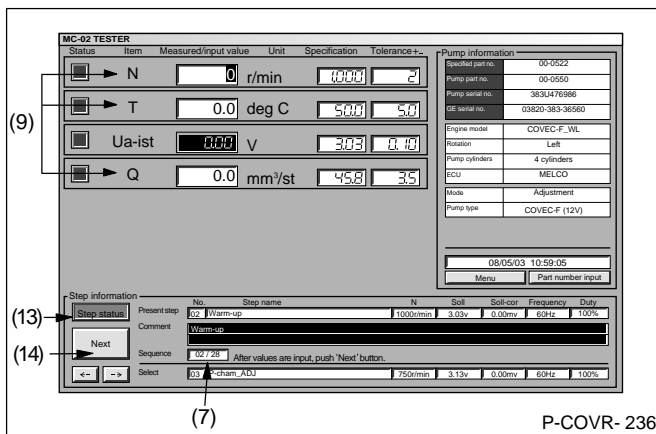

- (7) Confirm that the sequence is 02/28.
- (8) Run the injection pump at the specified speed N (see figure at left).
- (9) Measure N, T and Q on the pump test bench and input the values.

Note:

U α ist is displayed automatically.

- (10) Confirm injection.
- (11) Confirm that no fuel leaks from the injection pump fuel piping connections.

CAUTION

If there are any fuel leaks, if there is no injection or if any unusual noises occur during operation, stop test bench operation immediately and inspect the pump.

- (12) Confirm that the injection pump is operating normally.
- (13) Confirm that the Step status field is green.
- (14) Proceed to the next step.

Advice

Because the test oil temperature takes longer to increase in cold weather, turn the pump test bench on earlier.

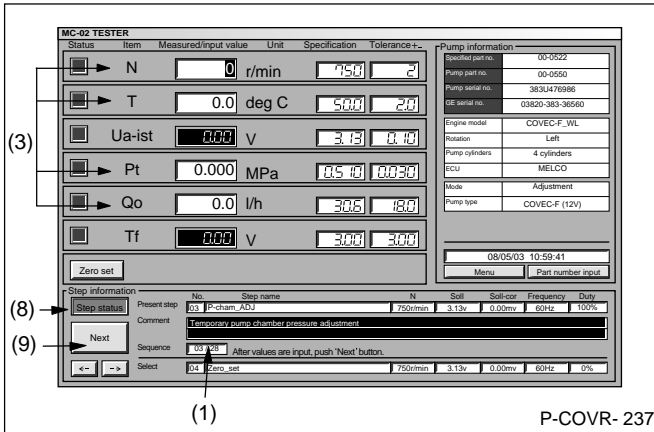

[8] Pump chamber pressure adjustment

- (1) Confirm that the sequence is 03/28.
- (2) Run the injection pump at the specified speed N (see figure at left).
- (3) Measure N, T, Pt and Qo on the pump test bench and input the values.

Note:

- U α ist and Tf are displayed automatically.
- (4) If Pt is as specified, perform steps (8) and (9) below. If Pt is not as specified, adjust as described below.

When the pump chamber pressure exceeds the specifications

- Stop the pump test bench and remove the regulating valve.
- Remove the spring ring using the pliers, then remove the piston and spring.

Tool name	Part no.	Remarks
Pliers	157829-2920	

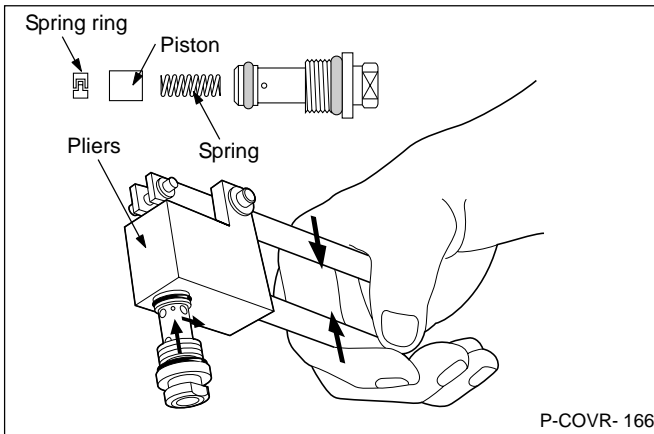

- Push the plug out to the end of the regulating valve using the pushrod.

Tool name	Part no.	Remarks
Pushrod	157829-5300	

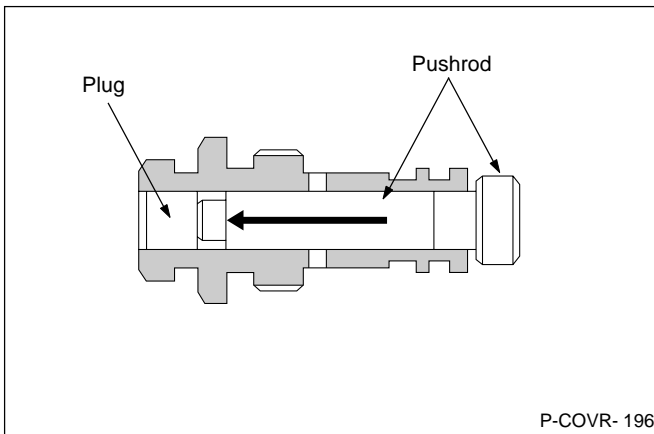

Note:

The pushrod (157829-5300) is part of the inserter (157829-5220).

- Insert the spring and piston into the regulating valve.
- Press fit a new spring ring into the regulating valve using the holder and a hammer.

Part name	Part no.	Remarks
Spring ring	146114-0000 (9 461 610 094)	

Tool name	Part no.	Remarks
Holder	157829-5200	

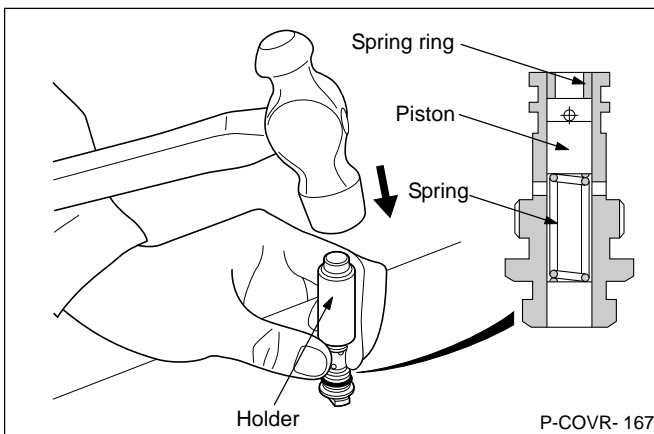

Note:

The holder (157829-5200) is part of the inserter (157829-5220).

4 ADJUSTMENT

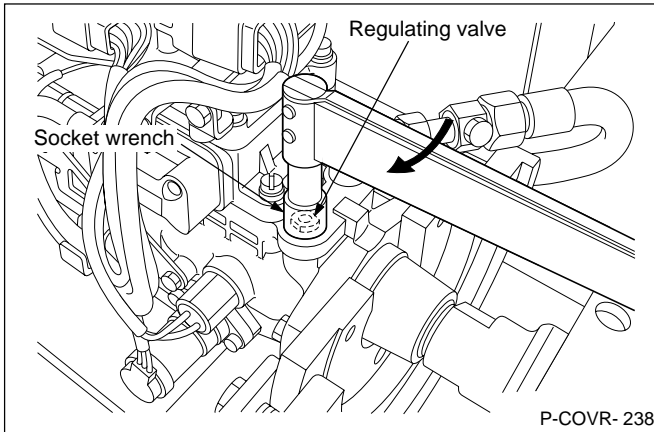

- Screw the regulating valve into the pump housing and tighten it to the specified torque using the socket wrench.

Specified torque: 11.0 ~ 13.0 N.m
{1.1 ~ 1.3 kgf.m}

Tool name	Part no.	Remarks
Socket wrench	157913-7000	

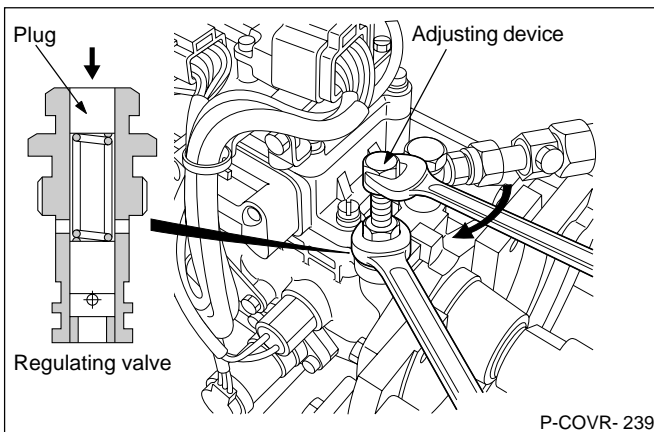

When the pump chamber pressure is less than the specifications

- Attach the adjusting device to the regulating valve.
- Gradually press the regulating valve plug into the regulating valve assembly using the adjusting device to adjust the pump chamber pressure.

Advice

Do not press the plug in too far.

- While reading the pump chamber pressure, adjust to within specifications using the adjusting device.

Tool name	Part no	Remarks
Adjusting device	157829-0820	

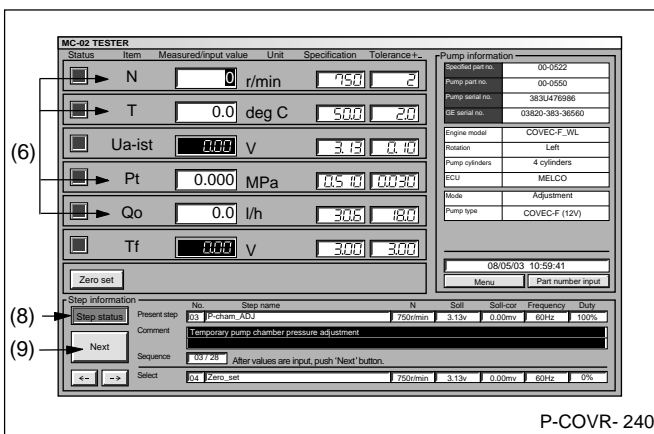

- Measure N, T, Pt and Qo again on the pump test bench and input the values.
- Confirm that the injection pump is operating normally.
- Confirm that the Step status field is green.
- Proceed to the next step.

Advice

If the overflowing quantity is not as specified after confirming pump chamber pressure, check the overflow valve.

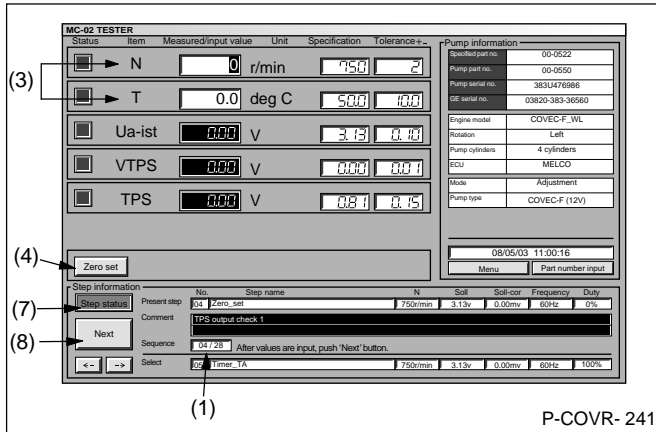

[9] TPS zero setting

- (1) Confirm that the sequence is 04/28.
- (2) Run the injection pump at the specified speed N (see figure at left).
- (3) Measure N and T on the pump test bench and input the values.

Note:

$U \propto ist$, VTPS and TPS are displayed automatically.

- (4) Press the 'Zero set' key and confirm that the VTPS value is within the specifications.

Note:

VTPS is the voltage value for when the timer piston is 0 mm.

- (5) If the TPS is as specified, perform steps (7) and (8) below. If the TPS is not as specified, replace the TPS standard point shim to adjust the TPS initial output.

Note:

- For pumps for Mazda WL engines, a TPS standard point shim with a thickness of 0.6 mm is assembled as standard.

Shim part no.	Thickness	Outer dia, inner dia
146603-0700 (9 461 610 447)	0.6	17.5, 7.5

- For pumps for Mitsubishi 4D56 engines, select shims from the table below.

Shim part no	Th/ness (mm)	Shim part no	Th/ness (mm)
146603-0700 (9 461 610 447)	0.6	146603-1000 (9 461 610 450)	1.0
146603-0800 (9 461 610 448)	0.7	146603-1100 (9 461 610 451)	1.2
146603-0900 (9 461 610 449)	0.9	146603-3600 (9 461 610 452)	2.4

- (6) Measure N and T again on the pump test bench and input the values.
- (7) Confirm that the Step status field is green.
- (8) Proceed to the next step.

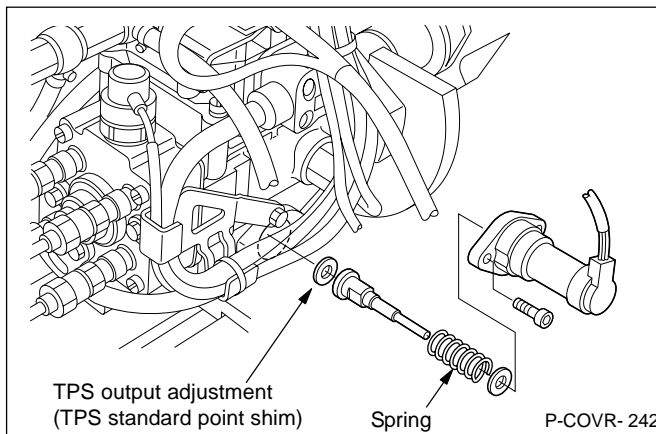

4 ADJUSTMENT

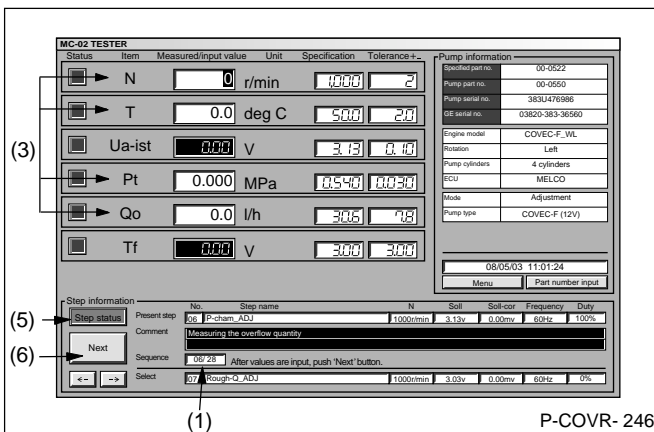
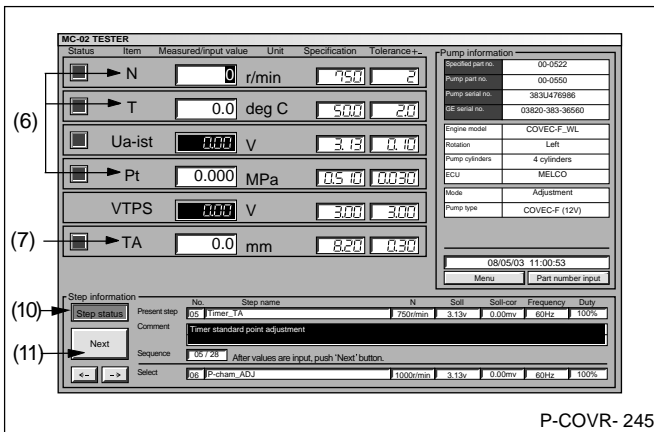
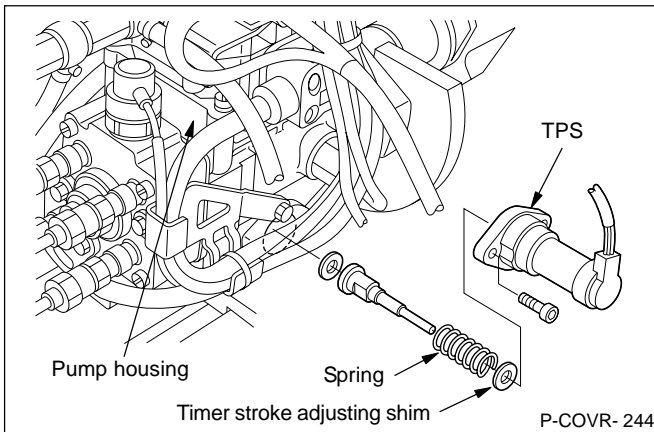
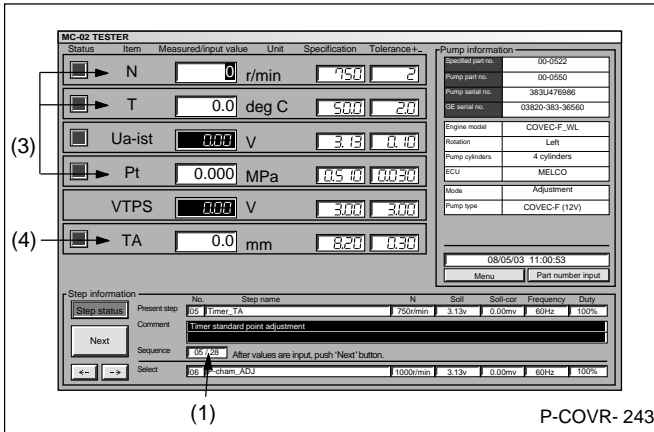

[10] Timer stroke adjustment and characteristic confirmation

- (1) Confirm that the sequence is 05/28.
- (2) Run the injection pump at the specified speed N (see figure at left).
- (3) Measure N, T and Pt on the pump test bench and input the values.
- (4) Measure TA from the measuring device and input the value.

Note:

U α ist and VTPS are displayed automatically.

- (5) If the timer stroke TA is not as specified, replace the timer stroke adjusting shim until the timer stroke is as specified.

Shim part no	Th/ness (mm)	Shim part no	Th/ness (mm)
146603-0700 (9 461 610 447)	0.6	146603-1000 (9 461 610 450)	1.0
146603-0800 (9 461 610 448)	0.7	146603-1100 (9 461 610 451)	1.2
146603-0900 (9 461 610 449)	0.9	146603-3600 (9 461 610 452)	2.4

- (6) Measure N, T and Pt on the pump test bench and input the values.
- (7) Measure TA from the measuring device and input the value.
- (8) Confirm that the timer stroke is as specified.
- (9) Confirm that the pump chamber pressure is as specified.
- (10) Confirm that the Step status field is green.
- (11) Proceed to the next step.

[11] Measuring the overflow quantity

- (1) Confirm that the sequence is 06/28.
- (2) Run the injection pump at the specified speed N (see figure at left).
- (3) Measure N, T, Pt and Qo on the pump test bench and input the values.

Note:

U α ist and TF are displayed automatically.

- (4) Confirm the overflow quantity.
- (5) Confirm that the Step status field is green.
- (6) Proceed to the next step.

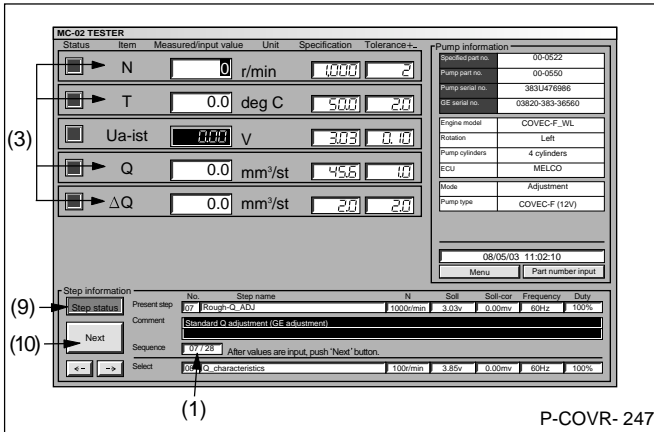

[12] Standard injection quantity point adjustment

- (1) Confirm that the sequence is 07/28.
- (2) Run the injection pump at the specified speed N (see figure at left).
- (3) Measure N, T, Q and DQ (ΔQ) on the pump test bench and input the values.

Note:

U α ist is displayed automatically.

- (4) If Q is as specified, perform steps (9) and (10) below. If Q is not as specified, adjust as described below.

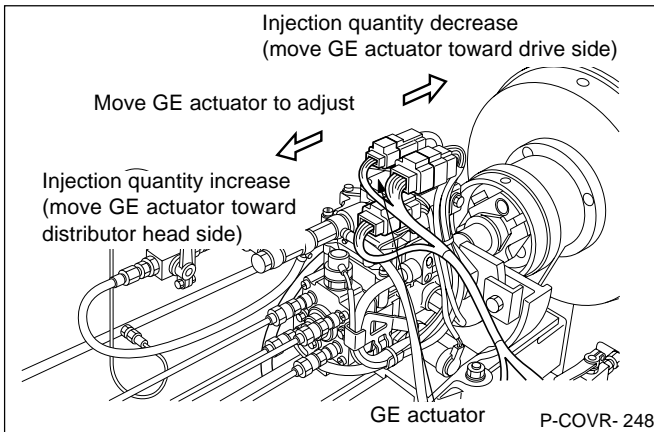

- (5) To adjust the fuel injection quantity, loosen the torx screws so that the GE actuator can move a little.

- (6) Move the GE actuator in the drive shaft's axial direction to adjust the full load injection quantity. (To increase the injection quantity, move the GE actuator toward the distributor head. To decrease the injection quantity, move the GE actuator toward the drive side.) Record the measured injection quantity and the position of the GE actuator to facilitate adjustment.

- (7) Following adjustment, tighten the torx screws to the specified torque.

**Specified torque: 7 ~ 10 N.m
{0.7 ~ 1.0 kgf.m}**

- (8) Measure N, T, Q and DQ (ΔQ) again on the pump test bench and input the values.
- (9) Confirm that the Step status field is green.
- (10) Proceed to the next step.

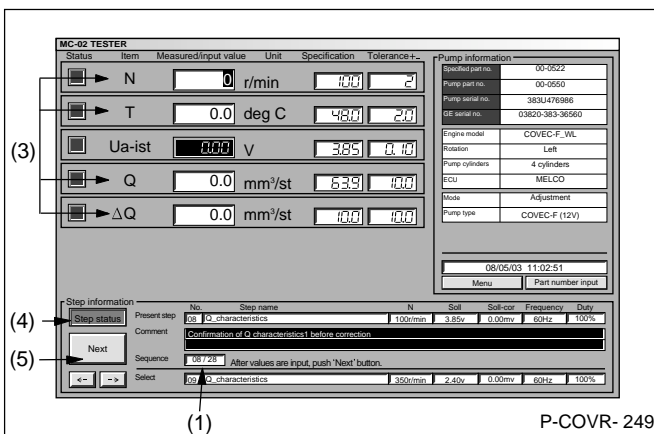

[13] Injection quantity compensation pre-confirmation

- (1) Confirm that the sequence is 08/28.
- (2) Run the injection pump at the specified speed N (see figure at left).
- (3) Measure N, T, Q and DQ (ΔQ) on the pump test bench and input the values.

Note:

U α ist is displayed automatically.

- (4) Confirm that the Step status field is green.
- (5) Proceed to the next step.

4 ADJUSTMENT

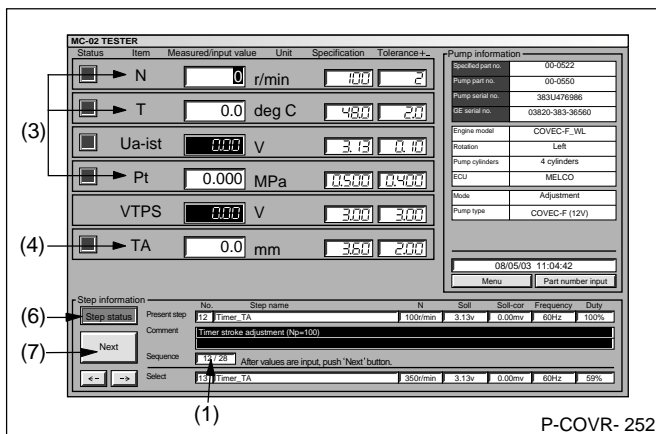
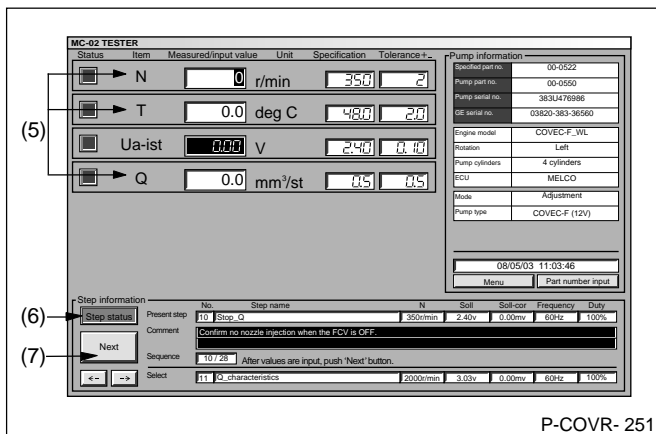
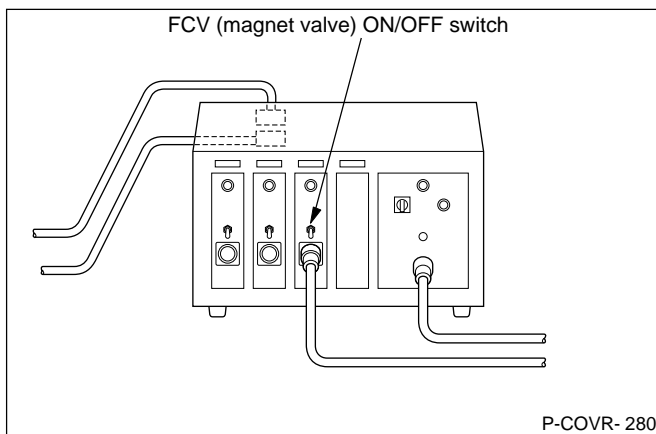
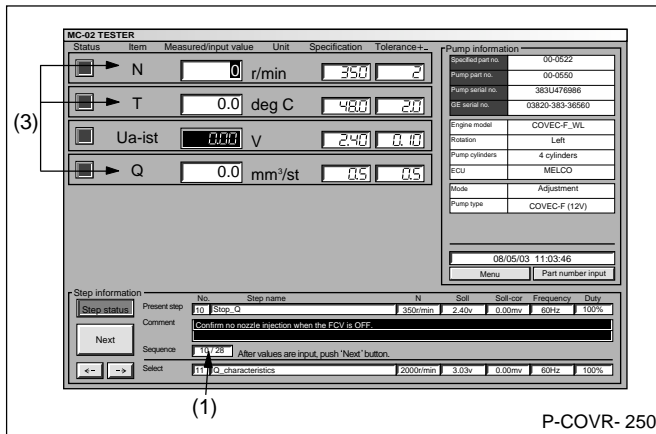

[14] Magnet valve operation confirmation

- (1) Confirm that the sequence is 10/28.
- (2) Run the injection pump at the specified speed N (see figure at left).
- (3) Measure N, T and Q on the pump test bench and input the values.

Note:

U α ist is displayed automatically.

- (4) Turn the FCV (magnet valve) ON/OFF switch OFF and confirm that non-injection results.

Advice

To confirm non-injection from the nozzle, look at the monitor screen and confirm that non-injection occurs within a short time (6 ~ 7 seconds).

- (5) Measure N, T and Q again on the pump test bench and input the values.
- (6) Confirm that the Step status field is green.
- (7) Proceed to the next step.

[15] Timer stroke confirmation

- (1) Confirm that the sequence is 12/28.
- (2) Run the injection pump at the specified speed N (see figure at left).
- (3) Measure N, T and Pt on the pump test bench and input the values.
- (4) Measure TA from the measuring device and input the value.

Note:

- U α ist and VTPS are displayed automatically.
- (5) Confirm that the timer stroke is as specified.
- (6) Confirm that the Step status field is green.
- (7) Proceed to the next step.

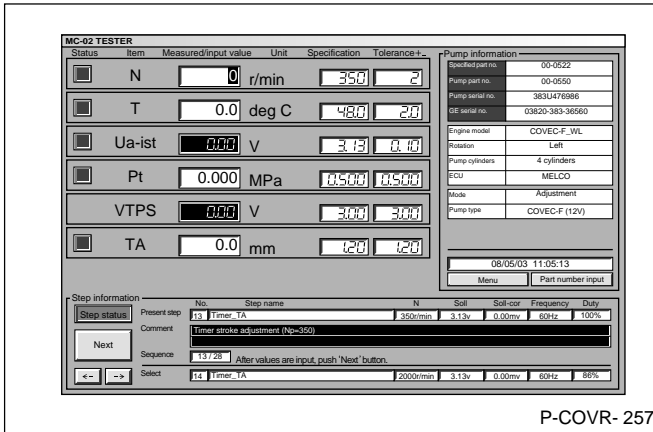

P-COVR- 257

Confirm 350 revolutions (Step 13/28) ~ 2,200 revolutions (Step 15/28) using the same procedure used for 100 revolutions (Step 12/28) above.

Advice

Repeat Step 04/28 if the timer stroke is not as specified.

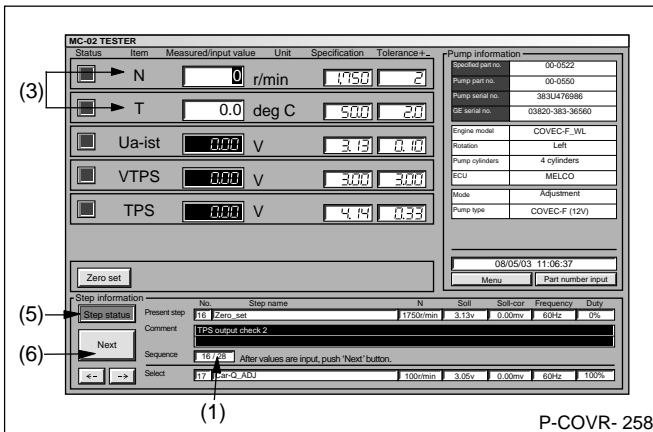

P-COVR- 258

[16] TPS confirmation

- (1) Confirm that the sequence is 16/28.
- (2) Run the injection pump at the specified speed N (see figure at left).
- (3) Measure N and T on the pump test bench and input the values.

Note:

U \propto ist, VTPS and TPS are displayed automatically.

- (4) Confirm that the TPS value is within the specified range.

Note:

VTPS is the voltage value for when the timer piston is in the full stroke position.

- (5) Confirm that the Step status field is green.
- (6) Proceed to the next step.

4 ADJUSTMENT

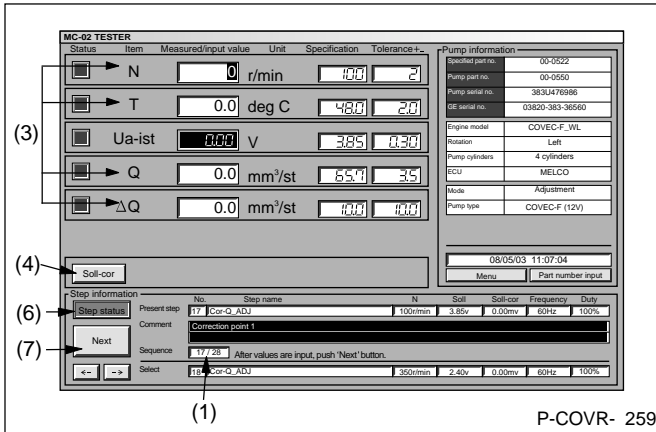

[17] Injection quantity compensation point adjustment

- (1) Confirm that the sequence is 17/28.
- (2) Run the injection pump at the specified speed N (see figure at left).
- (3) Measure N, T, Q and DQ (ΔQ) on the pump test bench and input the values.

Note:

U α ist is displayed automatically.

- (4) If the injection quantity is not as specified, press the 'Soll-cor' setting, input the soll compensation voltage and adjust the injection quantity to the specification.
- (5) Measure the injection quantity and confirm that it is as specified.

Advice

With the Soll-cor setting, the compensation voltage range differs with the service data or the calculation file. If the compensation voltage range is exceeded, a 'Reset' message is displayed.

When the injection quantity is greater than the specification

Input a minus to the compensation voltage and input the value.

When the injection quantity is less than the specification

Input the value only to the compensation voltage (a plus is not necessary).

- (6) Confirm that the Step status field is green.
- (7) Proceed to the next step.

Adjust compensation point 2 (Step 18/28) ~ compensation point 10 (Step 26/28) using the same procedure used for compensation point 1 (Step 17/28) above.

- (1) After adjusting the compensation point 1, press the 'Next' button to automatically proceed to Step 27/28.

[18] Compensation ROM interpolation calculation

Note:

In Step 27/28 the adjustment software automatically performs the calculations.

Advice

If the compensation voltage Soll values are not correct, compensation calculations are not performed and an error message is displayed. If an error message is displayed, repeat Step 17/28.

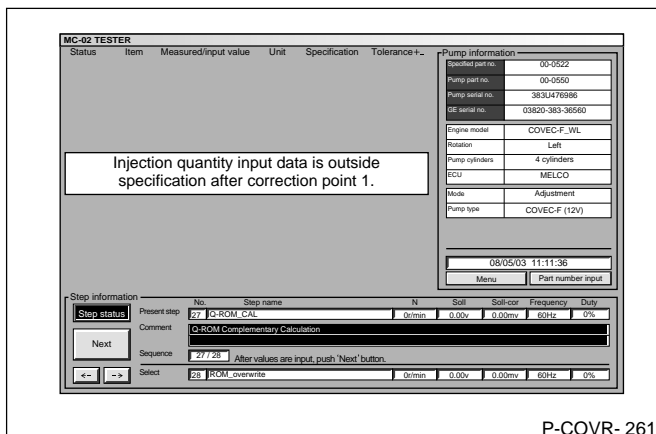
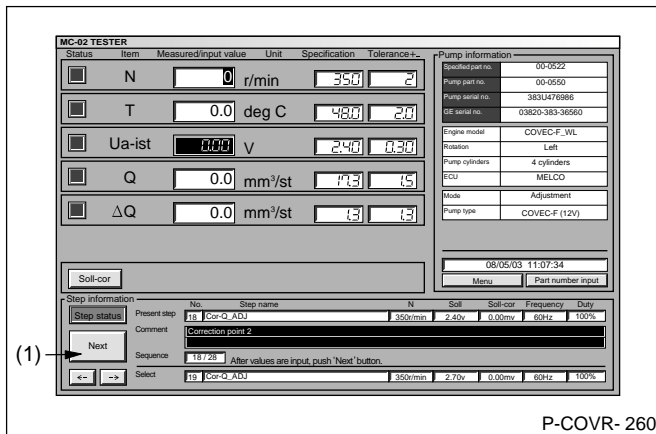

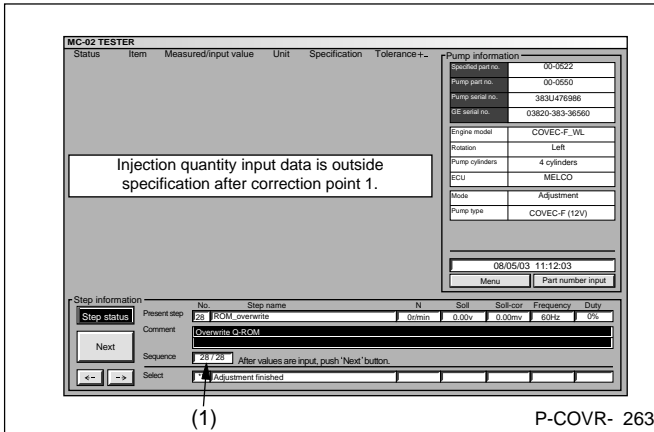

(1)

[19] Writing to the compensation ROM

- (1) Press Step 27/28 to automatically display the step 28/28.
- (2) The adjustment software automatically writes the compensation Q data to the injection pump's Q adjustment ROM.

Advice

Never touch the computer, the injection pump or the connecting wire harnesses while writing to the ROM.

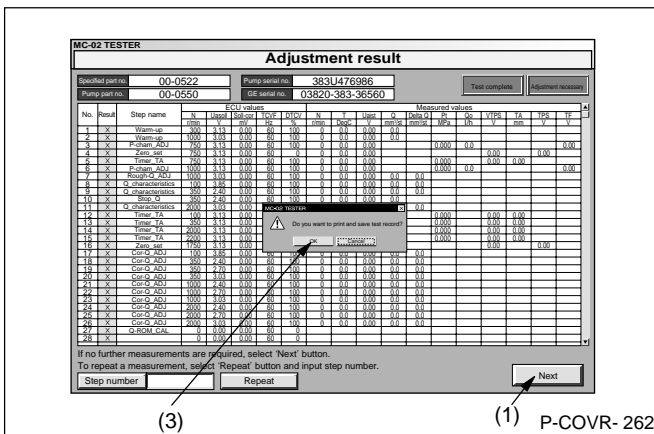

(3)

(1)

[20] Printing the adjustment result and saving the data

- (1) Click the 'Next' key.
- (2) The message 'Do you want to print and save test record' appears.
- (3) Click 'OK.'

Note:

If you select 'Cancel,' you cannot continue to the next step.

Advice

- The printed test record can be given to the customer.
 - The saved test record is a record of all the data and must be handled carefully.
- (4) Turn the controller unit's sub-switch OFF.
 - (5) Turn the controller unit's main switch OFF.

5 INSPECTION

INSPECTION

Inspection sequence

Note:

The following describes inspection of the COVEC-F pump for Mazda WL engines.

For Mitsubishi 4D56 engines, the inspection sequence, the wiring harnesses and connections, and the ECU assembly used differ from those of Mazda engines.

The details of the inspection procedures, however are the same. Refer to page 11 for the wiring outline for Mitsubishi 4D56 engines.

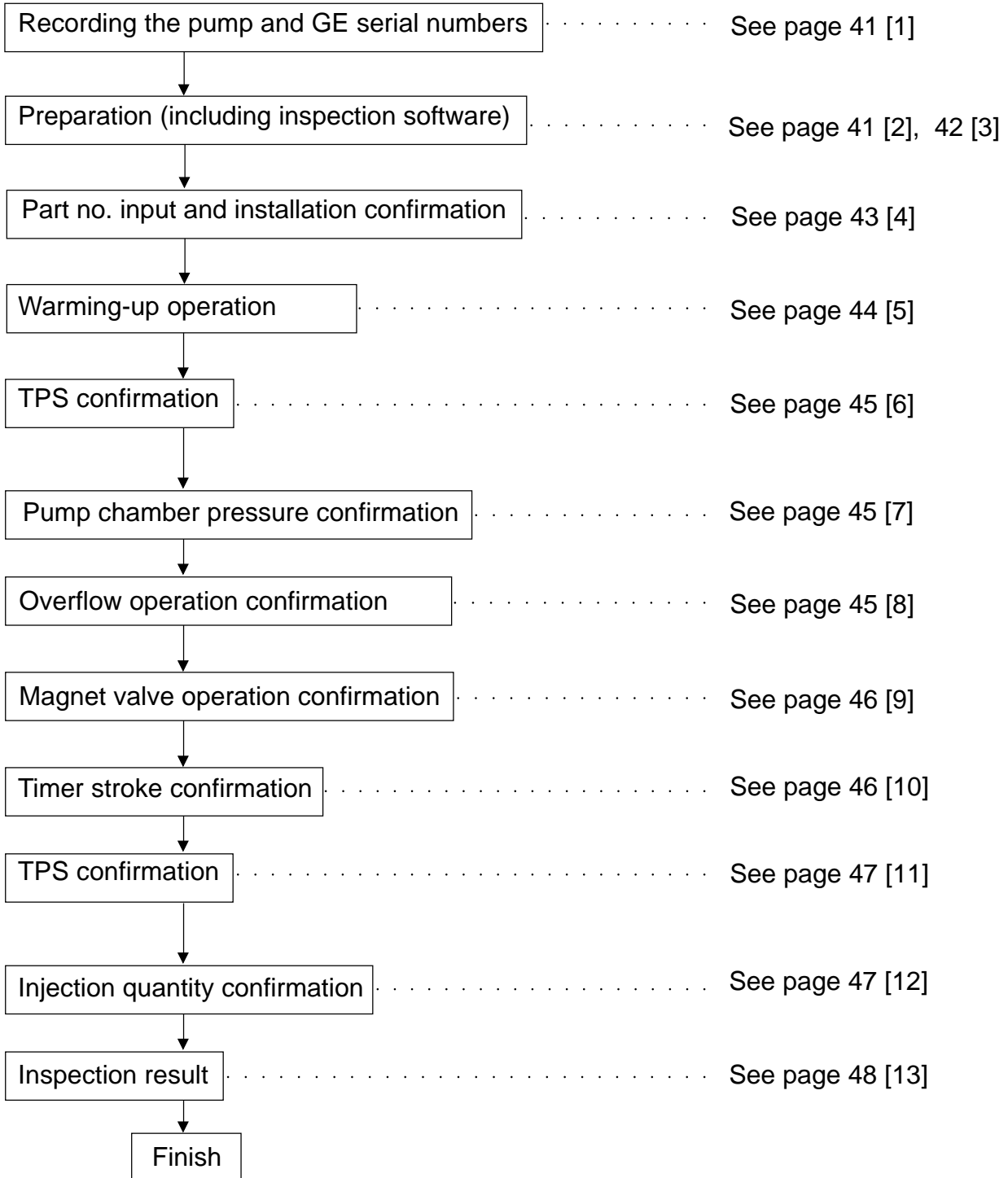

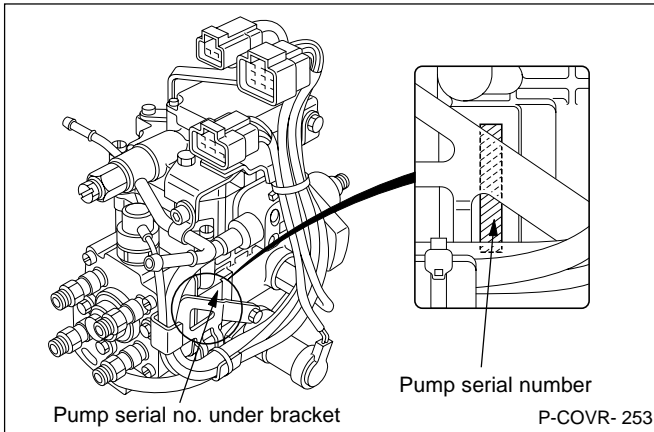

[1] Recording the pump and GE serial numbers

- (1) Read and record the 10 digit pump serial number.

Advice

It is easier to read the pump's serial number before beginning 'Preparation.'

Note:

Serial number input is used during adjustment mode and inspection mode.

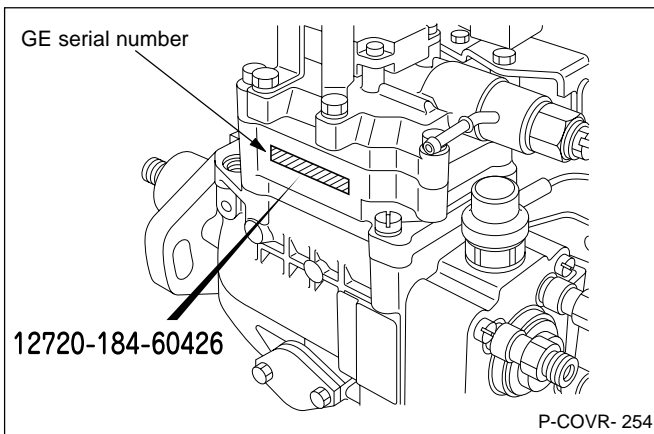

- (2) Read and record the 13 digit GE actuator serial number.

Advice

It is easier to read the GE actuator's serial number before beginning 'Preparation.'

Note:

Serial number input is used during adjustment mode and inspection mode.

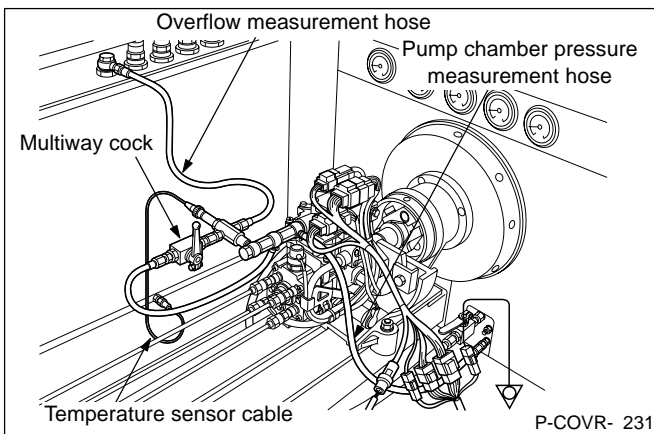

[2] Preparation

- (1) Connect the test oil hose to the injection pump. (Refer to page 10 for the fuel piping.)
- (2) Connect the injection system piping to the injection pump. (Refer to page 9 for the injection system piping.)
- (3) Connect the controller assembly's wire harness and intermediate harness to the injection pump's connectors. (Refer to page 11 for the controller assembly's wiring. The following describes Mazda wiring.)
- (4) Connect the wire harness to the controller unit's ECU assembly connector (Mazda: No. 3; Mitsubishi: No. 1).
- (5) Connect the ROM controller's wire harness to the intermediate harness.
- (6) Connect the FCV GND harness to the controller assembly's wire harness and to earth.
- (7) Connect the D-Sub 9 pin cable connector (COM 1) on the rear of the controller unit to the personal computer using the wire harness.
- (8) Connect the D-Sub 25 pin cable connector (COM 2) on the rear of the controller unit to the personal computer using the wire harness.

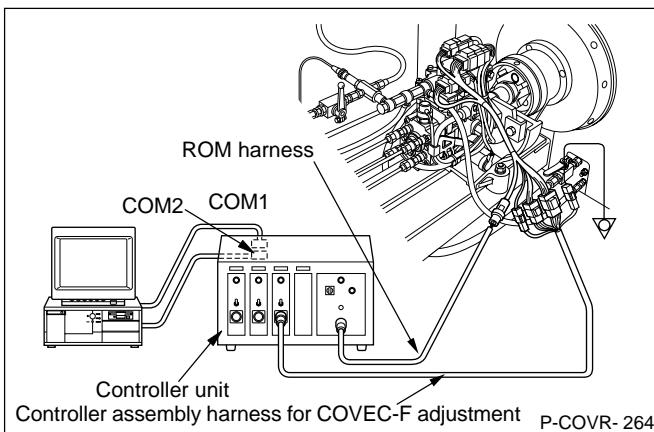

5 INSPECTION

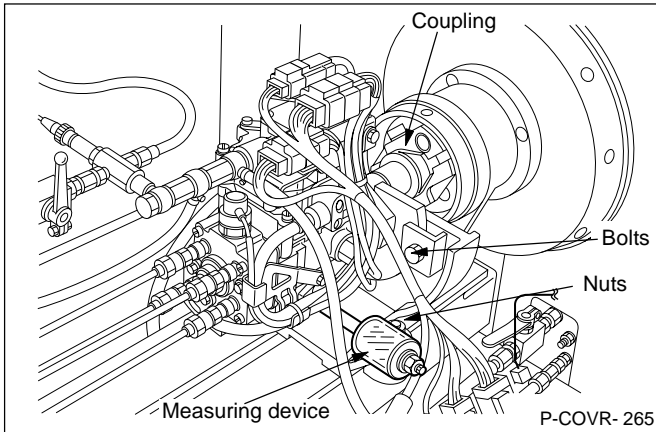

- (9) Reconfirm that the coupling and the fixing stand bolts and nuts are securely tightened.
- (10) Attach the measuring device to the injection pump.

Tool name	Part no.	Remarks
Measuring device	105782-8260	

- (11) Set the 20NP pump tester's test oil outlet temperature at 45°C.

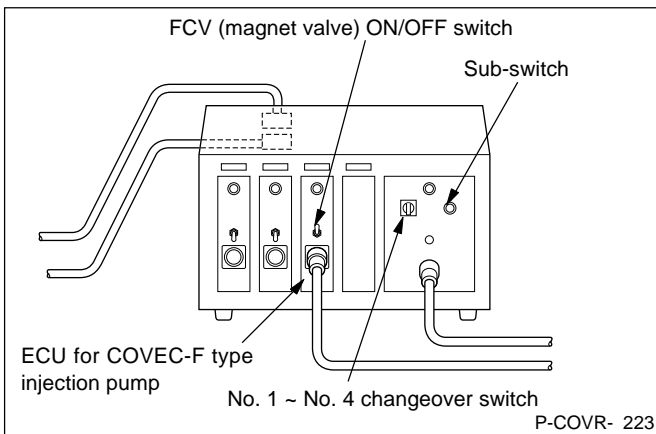

- (12) Turn the main switch on the rear of the controller unit ON.
- (13) Set the No 1 ~ No 4 changeover switch at the relevant setting (Mazda: No. 3; Mitsubishi: No. 1).
- (14) Turn the FCV (magnet valve) ON/OFF switch ON to energize the magnet valve.
- (15) Turn the sub-switch on the front of the controller unit ON.

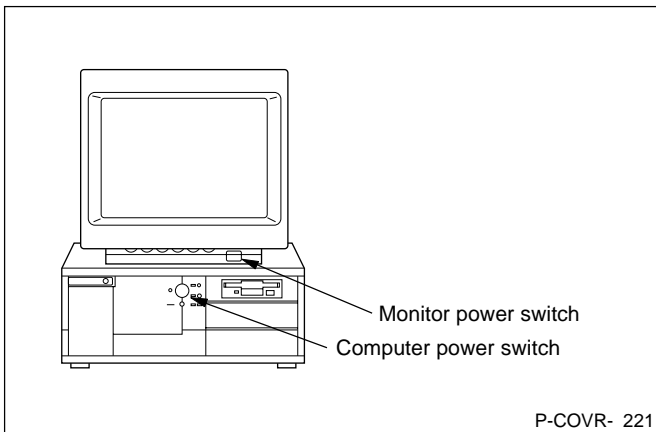

[3] Inspection software set up

- (1) Turn the computer and the monitor power switches ON.

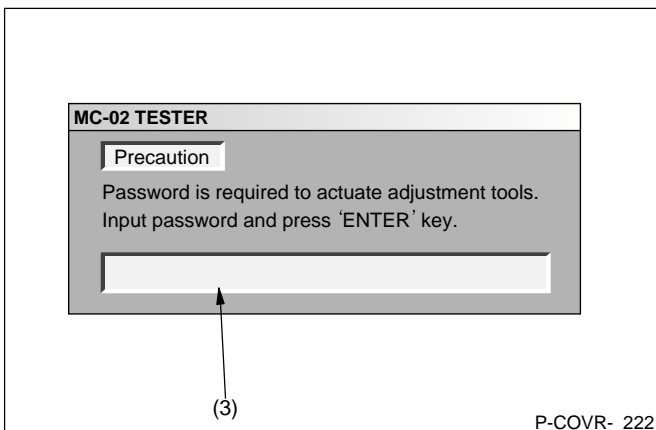

- (2) Start the 'Service tools for pump adjustment' software.
- (3) Input the password and press the 'Enter' key.

Advice

Input the initial default password ('RBAJ') or your own password.

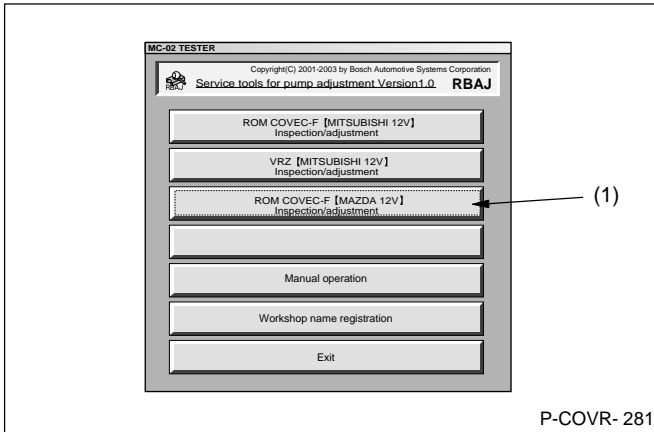

[4] Part number input and installation confirmation

- (1) Select the Inspection/adjustment button (Mazda: 'ROM COVEEC-F [MAZDA 12V] Inspection/adjustment'; Mitsubishi: 'ROM COVEEC-F [MITSUBISHI 12V] Inspection/adjustment').

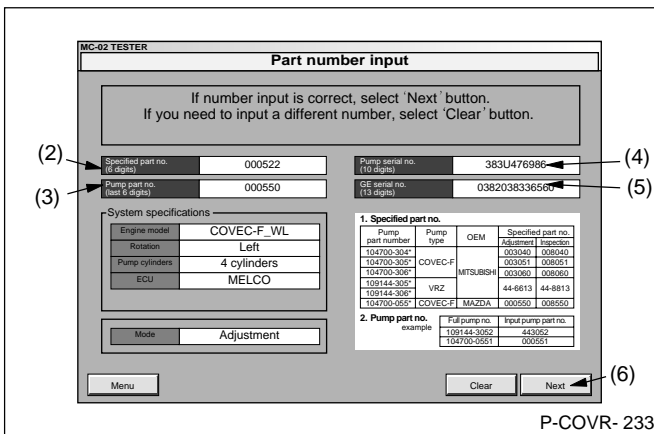

- (2) When the dialog shown at left appears, input the specified part number (6 digits).
- (3) Input the pump part number (last 6 digits).
- (4) Input the pump serial number (10 digits).
- (5) Input the GE's serial number (13 digits).
- (6) Press the 'Next' key.

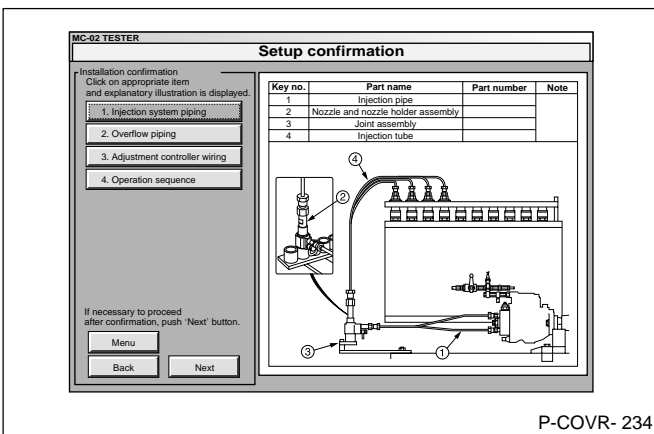

- (7) Confirm that the screen changes to the injection system piping display.
- (8) Select '1. Injection system piping.'

Note:
Clicking the different buttons (1. Injection system piping, 2. Overflow piping, 3. Adjustment controller wiring, and 4. Operation sequence) displays different Setup confirmation screens.

5 INSPECTION

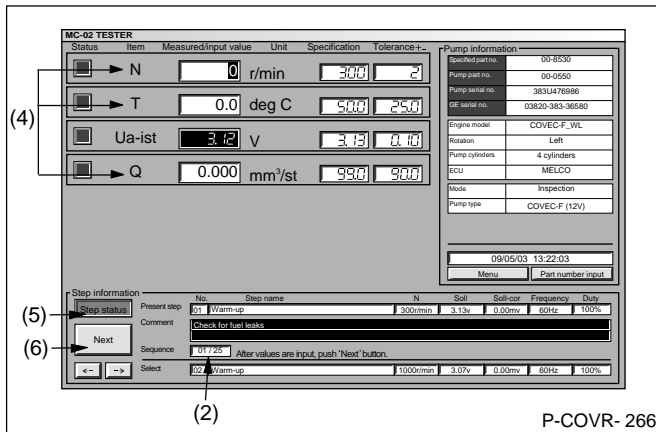

[5] Warming-up operation

- (1) Set the pump test bench delivery pressure at the specified 20 kPa {0.2 kgf/cm²}.
- (2) Confirm that the sequence is 01/25.
- (3) Run the injection pump at the specified speed N (see figure at left).
- (4) Measure N, T and Q on the pump test bench and input the values.

Note:

U α ist is displayed automatically.

- (5) Confirm that the Step status field is green.
- (6) Proceed to the next step.

Advice

- If U α ist values are not as specified, press the 'Next' button several times. Then, return to Step 01/25 using the back arrow.

Repeat the Step 01/25 and confirm that U α ist values are as specified.

Note:

If not as specified after confirming U α ist several times, the GE may be faulty.

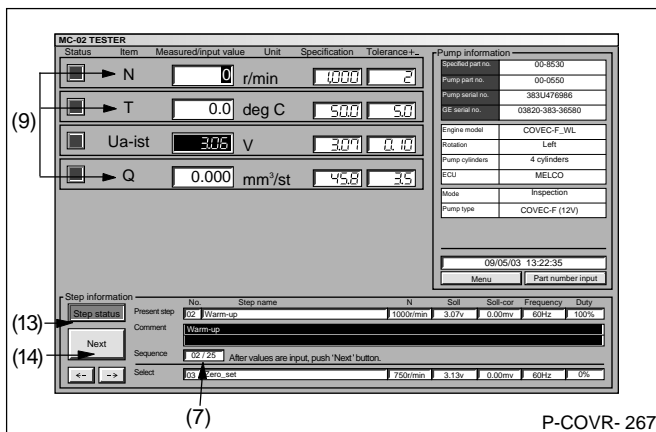

- (7) Confirm that the sequence is 02/25.
- (8) Run the injection pump at the specified speed N (see figure at left).
- (9) Measure N, T and Q on the pump test bench and input the values.

Note:

U α ist is displayed automatically.

- (10) Confirm injection.
- (11) Confirm that no fuel leaks from the injection pump fuel piping connections.

⚠ CAUTION

If there are any fuel leaks, if there is no injection or if any unusual noises occur during operation, stop test bench operation immediately and inspect the pump.

- (12) Confirm that the injection pump is operating normally.
- (13) Confirm that the Step status field is green.
- (14) Proceed to the next step.

Advice

Because the test oil temperature takes longer to increase in cold weather, turn the pump test bench on earlier.

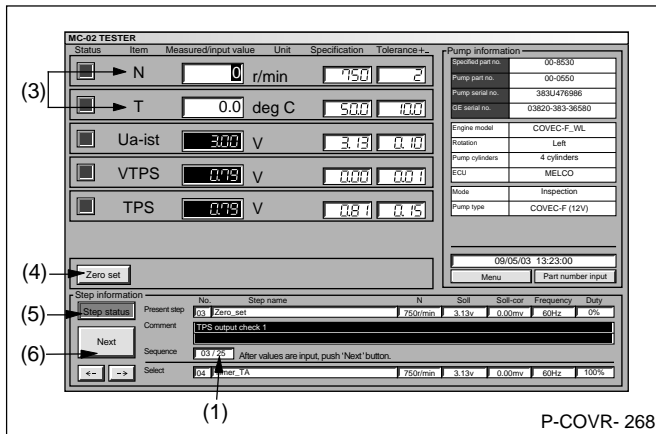

[6] TPS confirmation

- (1) Confirm that the sequence is 03/25.
- (2) Run the injection pump at the specified speed N (see figure at left).
- (3) Measure N and T on the pump test bench and input the values.

Note:

U α ist, VTPS and TPS are displayed automatically.

- (4) Push the 'Zero set' key and confirm that the VTPS value is within the specified range.
- (5) Confirm that the Step status field is green.
- (6) Proceed to the next step.

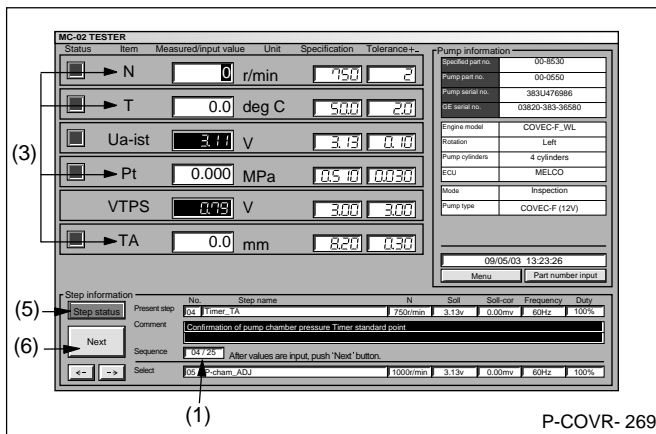

[7] Pump chamber pressure confirmation

- (1) Confirm that the sequence is Step 04/25.
- (2) Run the injection pump at the specified speed N (see figure at left).
- (3) Measure N, T, Pt and TA on the pump test bench and input the values.

Note:

U α ist and VTPS are displayed automatically.

- (4) Confirm the pump chamber pressure.
- (5) Confirm that the Step status field is green.
- (6) Proceed to the next step.

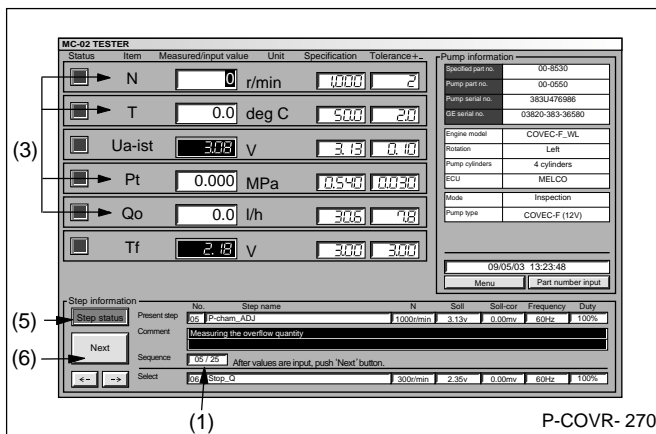

[8] Overflow operation confirmation

- (1) Confirm that the sequence is 05/25.
- (2) Run the injection pump at the specified speed N (see figure at left).
- (3) Measure N, T, Pt and Qo on the pump test bench and input the values.

Note:

U α ist and TF are displayed automatically.

- (4) Confirm the pump chamber pressure.
- (5) Confirm that the Step status field is green.
- (6) Proceed to the next step.

5 INSPECTION

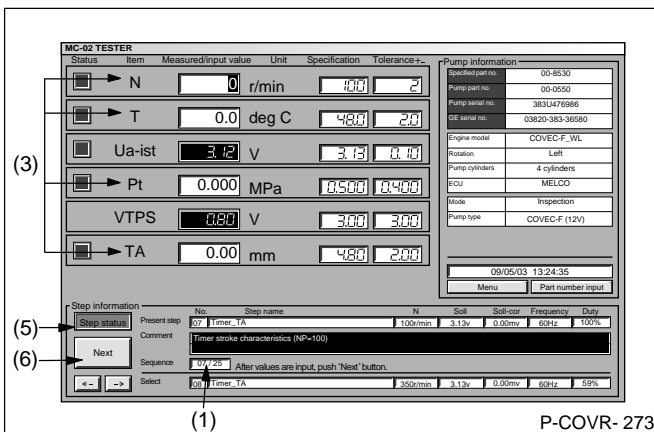
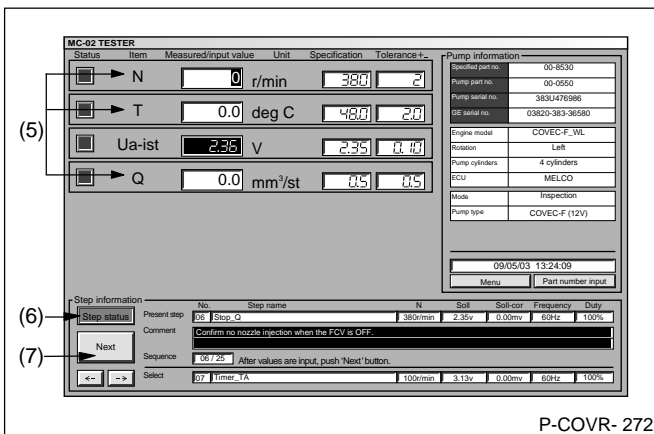
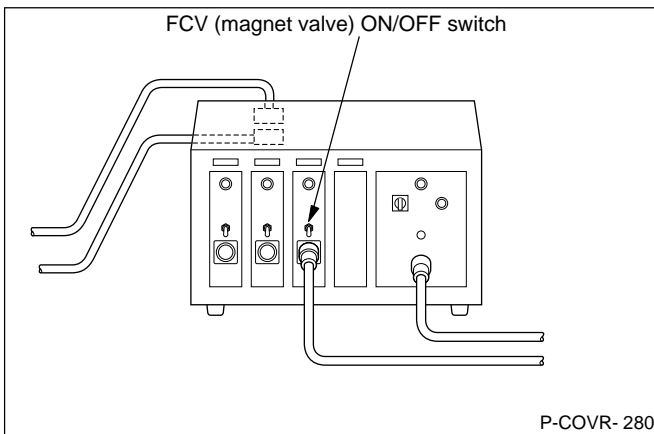
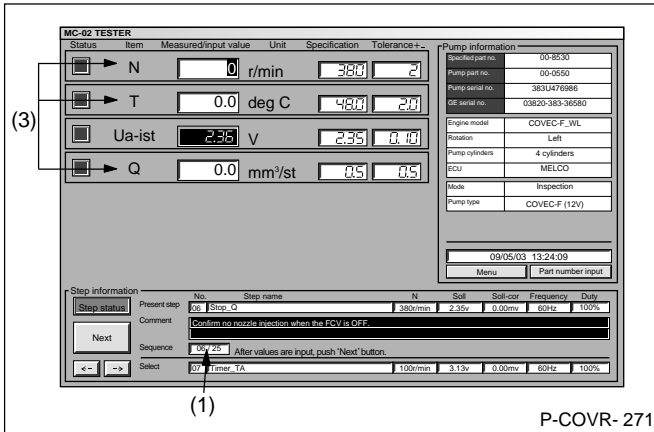

[9] Magnet valve operation confirmation

- (1) Confirm that the sequence is 06/25.
- (2) Run the injection pump at the specified speed N (see figure at left).
- (3) Measure N, T and Q on the pump test bench and input the values.

Note:

U α ist is displayed automatically.

- (4) Turn the FCV (magnet valve) ON/OFF switch OFF and confirm that non-injection results.

Advice

To confirm non-injection from the nozzle, look at the monitor screen and confirm that non-injection occurs within a short time (6 ~ 7 seconds).

- (5) Measure N, T and Q again on the pump test bench and input the values.
- (6) Confirm that the Step status field is green.
- (7) Proceed to the next step.

[10] Timer stroke confirmation

- (1) Confirm that the sequence is Step 07/25.
- (2) Run the injection pump at the specified speed N (see figure at left).
- (3) Measure N, T and Pt on the pump test bench and input the values. Measure TA from the measuring device and input the value.

Note:

- U α ist and VTPS are displayed automatically.
- (4) Confirm that the timer stroke TA is within the specifications.
- (5) Confirm that the Step status field is green.
- (6) Proceed to the next step.

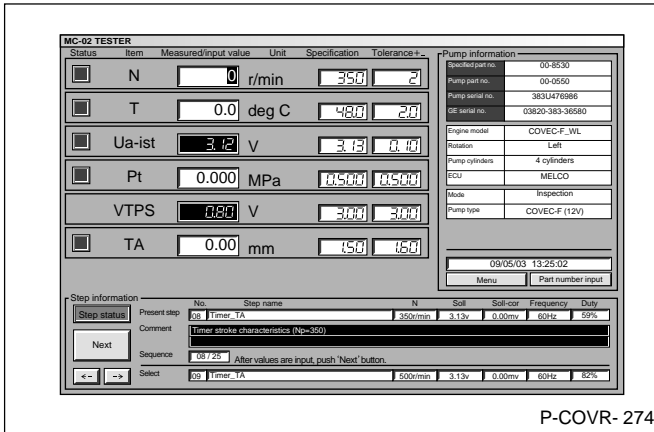

Confirm 350 revolutions (Step 08/25) ~ 2,200 revolutions (Step 14/25) using the same procedure used for 100 revolutions (Step 07/25) above.

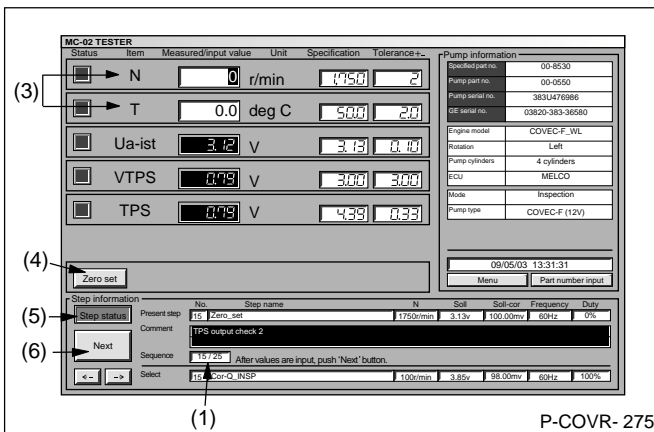

[11] TPS confirmation

- (1) Confirm that the sequence is Step 15/25.
- (2) Run the injection pump at the specified speed N (see figure at left).
- (3) Measure N and T on the pump test bench and input the values.

Note:

U α ist, VTPS and TPS are displayed automatically.

- (4) Press the 'Zero set' key and confirm that the VTPS value is within the specifications.
- (5) Confirm that the Step status field is green.
- (6) Proceed to the next step.

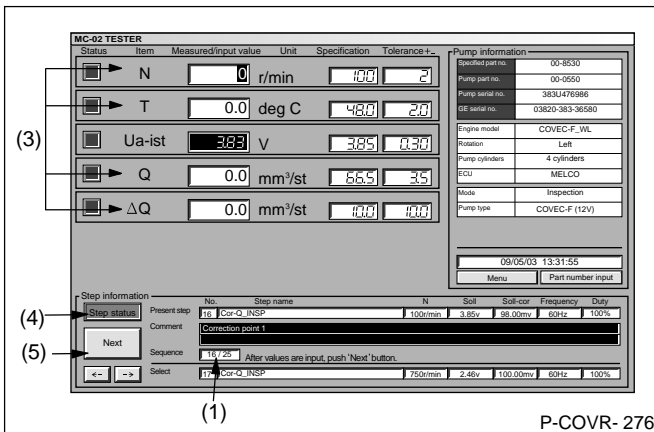

[12] Injection quantity confirmation

- (1) Confirm that the sequence is Step 16/25.
- (2) Run the injection pump at the specified speed N (see figure at left).
- (3) Measure N, T, Q and DQ (ΔQ) on the pump test bench and input the values.

Note:

U α ist is displayed automatically.

Advice

Do not perform injection quantity adjustment.

- (4) Confirm that the Step status field is green.
- (5) Proceed to the next step.

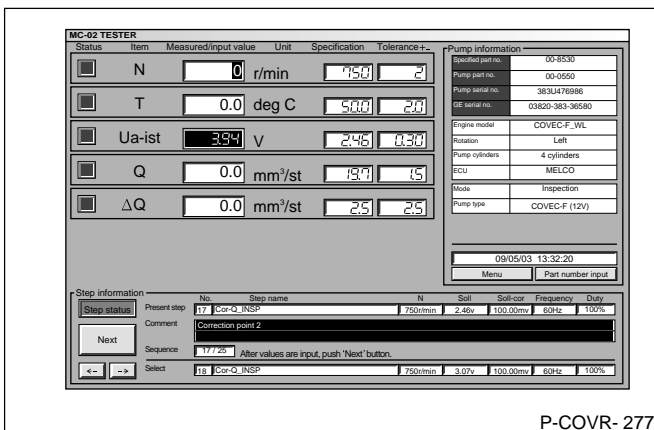

Confirm compensation point 2 (Step 17/25) ~ compensation point 10 (Step 25/25) using the same procedure used for compensation point 1 (Step 16/25) above.

5 INSPECTION

MC-02 TESTER

Inspection result

Specified part no. 00-8530 Pump serial no. 383U476986 Test complete. [] []

Part no. 00-0550 Control no. 03820-383-36580

No.	Result	Step name	ECU value										Measured value										
			A	Uapp	ISLSP	TOP	MPV	M	T	Ugr	Q	Delta Q	IS	IS	IS	IS	IS	IS	IS	IS	IS	IS	
1	X	Warm-up	300	3.12	0.00	0.0	100	0	0.0	3.12	0.0												
2	X	Warm-up	300	3.12	0.00	0.0	100	0	0.0	3.12	0.0												
3	X	Warm-up	300	3.12	0.00	0.0	100	0	0.0	3.12	0.0												
4	X	Warm-up	300	3.12	0.00	0.0	100	0	0.0	3.12	0.0												
5	X	P-Start_ABS	1500	3.12	0.00	0.0	100	0	0.0	3.12	0.0	0.000	0.0	0.00	0.00	0.00	0.00	0.00	0.00	0.00	0.00	0.00	0.00
6	X	Temp-TA	100	3.12	0.00	0.0	100	0	0.0	3.12	0.0	0.000	0.00	0.00	0.00	0.00	0.00	0.00	0.00	0.00	0.00	0.00	0.00
7	X	Temp-TA	100	3.12	0.00	0.0	100	0	0.0	3.12	0.0	0.000	0.00	0.00	0.00	0.00	0.00	0.00	0.00	0.00	0.00	0.00	0.00
8	X	Temp-TA	100	3.12	0.00	0.0	100	0	0.0	3.12	0.0	0.000	0.00	0.00	0.00	0.00	0.00	0.00	0.00	0.00	0.00	0.00	0.00
9	X	Temp-TA	100	3.12	0.00	0.0	100	0	0.0	3.12	0.0	0.000	0.00	0.00	0.00	0.00	0.00	0.00	0.00	0.00	0.00	0.00	0.00
10	X	Temp-TA	100	3.12	0.00	0.0	100	0	0.0	3.12	0.0	0.000	0.00	0.00	0.00	0.00	0.00	0.00	0.00	0.00	0.00	0.00	0.00
11	X	Temp-TA	100	3.12	0.00	0.0	100	0	0.0	3.12	0.0	0.000	0.00	0.00	0.00	0.00	0.00	0.00	0.00	0.00	0.00	0.00	0.00
12	X	Temp-TA	100	3.12	0.00	0.0	100	0	0.0	3.12	0.0	0.000	0.00	0.00	0.00	0.00	0.00	0.00	0.00	0.00	0.00	0.00	0.00
13	X	Temp-TA	2200	3.12	0.00	0.0	100	0	0.0	3.12	0.0	0.000	0.00	0.00	0.00	0.00	0.00	0.00	0.00	0.00	0.00	0.00	0.00
14	X	Temp-TA	4500	3.12	0.00	0.0	100	0	0.0	3.12	0.0	0.000	0.00	0.00	0.00	0.00	0.00	0.00	0.00	0.00	0.00	0.00	0.00
15	X	Temp-TA	100	3.12	0.00	0.0	100	0	0.0	3.12	0.0	0.000	0.00	0.00	0.00	0.00	0.00	0.00	0.00	0.00	0.00	0.00	0.00
16	X	Cor-Q_INSP	100	3.12	0.00	0.0	100	0	0.0	3.12	0.0	0.000	0.00	0.00	0.00	0.00	0.00	0.00	0.00	0.00	0.00	0.00	0.00
17	X	Cor-Q_INSP	100	3.12	0.00	0.0	100	0	0.0	3.12	0.0	0.000	0.00	0.00	0.00	0.00	0.00	0.00	0.00	0.00	0.00	0.00	0.00
18	X	Cor-Q_INSP	100	3.12	0.00	0.0	100	0	0.0	3.12	0.0	0.000	0.00	0.00	0.00	0.00	0.00	0.00	0.00	0.00	0.00	0.00	0.00
19	X	Cor-Q_INSP	100	3.12	0.00	0.0	100	0	0.0	3.12	0.0	0.000	0.00	0.00	0.00	0.00	0.00	0.00	0.00	0.00	0.00	0.00	0.00
20	X	Cor-Q_INSP	1000	3.12	0.00	0.0	100	0	0.0	3.12	0.0	0.000	0.00	0.00	0.00	0.00	0.00	0.00	0.00	0.00	0.00	0.00	0.00
21	X	Cor-Q_INSP	1000	3.12	0.00	0.0	100	0	0.0	3.12	0.0	0.000	0.00	0.00	0.00	0.00	0.00	0.00	0.00	0.00	0.00	0.00	0.00
22	X	Cor-Q_INSP	1000	3.12	0.00	0.0	100	0	0.0	3.12	0.0	0.000	0.00	0.00	0.00	0.00	0.00	0.00	0.00	0.00	0.00	0.00	0.00
23	X	Cor-Q_INSP	1000	3.12	0.00	0.0	100	0	0.0	3.12	0.0	0.000	0.00	0.00	0.00	0.00	0.00	0.00	0.00	0.00	0.00	0.00	0.00
24	X	Cor-Q_INSP	1100	3.12	0.00	0.0	100	0	0.0	3.12	0.0	0.000	0.00	0.00	0.00	0.00	0.00	0.00	0.00	0.00	0.00	0.00	0.00
25	X	Cor-Q_INSP	1100	3.12	0.00	0.0	100	0	0.0	3.12	0.0	0.000	0.00	0.00	0.00	0.00	0.00	0.00	0.00	0.00	0.00	0.00	0.00
26	X	Cor-Q_INSP	1100	3.12	0.00	0.0	100	0	0.0	3.12	0.0	0.000	0.00	0.00	0.00	0.00	0.00	0.00	0.00	0.00	0.00	0.00	0.00
27	X	Cor-Q_INSP	1100	3.12	0.00	0.0	100	0	0.0	3.12	0.0	0.000	0.00	0.00	0.00	0.00	0.00	0.00	0.00	0.00	0.00	0.00	0.00
28	X	Cor-Q_INSP	1100	3.12	0.00	0.0	100	0	0.0	3.12	0.0	0.000	0.00	0.00	0.00	0.00	0.00	0.00	0.00	0.00	0.00	0.00	0.00

If no further measurements are required, select 'Next' button.
To repeat a measurement, select 'Repeat' button and input step number.

Step number [] Repeat [] Next []

(3) (1) P-COVR- 278

[13] Inspection result

- (1) Click the 'Next' key.
- (2) The message 'Do you want to print and save test record' appears.
- (3) Click 'OK.'

Note:

If you select 'Cancel,' you cannot continue to the next step.

Advice

- The printed test record can be given to the customer.
 - The saved test record is a record of all the data and must be handled carefully.
- (4) Turn the controller unit's sub-switch OFF.
 - (5) Turn the controller unit's main switch OFF.

6 TIGHTENING TORQUES

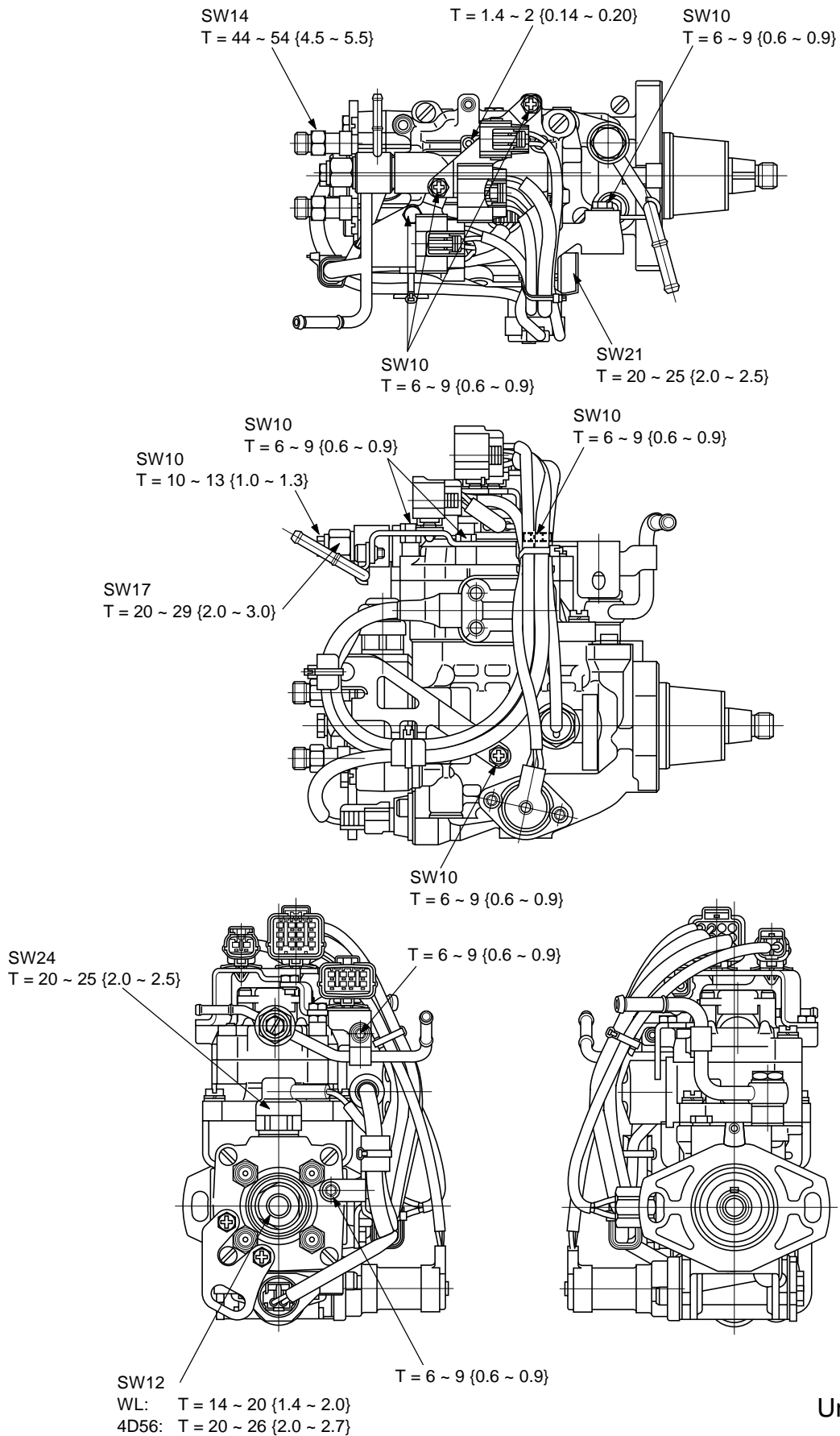

P-COVR-279

7 PART NUMBER EXPLANATION

1. INJECTION PUMP ASSEMBLY NUMBER

1 0 4 7 * * - * * * *
(1) (2) (3) (4) (5)

(1): VE type injection pump

(2): Number of cylinders

0 → 4 cylinders

1 → 6 cylinders

(3): Number of plungers - diameter

8 → $\phi 8$

6 → $\phi 11$

9 → $\phi 9$

1 → $\phi 11$

0 → $\phi 10$

2 → $\phi 12$

5 → $\phi 11$

(4): Proper number

(5): Suffix

2. BOSCH TYPE NUMBER

NP - VE - * / * E **** R NP****
(1) (2) (3) (4) (5) (6) (7) (8)

(1): Manufactured by Bosch Automotive Systems Corporation

(2): VE type injection pump

(3): Number of cylinders

(4): Plunger diameter

(5): E Electronic governor

F Mechanical governor

(6): Maximum controlled governor speed (r/min)

(7): Direction of pump rotation

R: clockwise viewed from drive side

L: counter clockwise viewed from drive side

(8): Proper number

Pub. No: EE14E-11190

FUEL INJECTION PUMP MODEL COVEC-F

Service Manual

Adjustment & Inspection

Printing: July 2003

Published by:

Bosch K.K.

Sales Automotive Aftermarket Division

Printed in Japan

© Copyright 2003, Bosch K.K

WPGVS-02