

INTERIOR AND SUPPLEMENTAL RESTRAINT SYSTEM (SRS)

CONTENTS

INTERIOR	52A
SUPPLEMENTAL RESTRAINT SYSTEM (SRS)	52B

INTERIOR

CONTENTS

SERVICE SPECIFICATIONS	3	FRONT SEAT	18
SPECIAL TOOL	3	REAR/SECOND SEAT	25
INSTRUMENT PANEL <L.H. DRIVE VEHICLES>*	4	THIRD SEAT	35
INSTRUMENT PANEL <R.H. DRIVE VEHICLES>*	8	FRONT SEAT BELT	38
FLOOR CONSOLE	12	REAR SEAT BELT<SHORT WHEELBASE> ..	40
TRIMS	13	SECOND/THIRD SEAT BELT <LONG WHEELBASE>	41
SUNVISOR HOLDER	17		

WARNINGS REGARDING SERVICING OF SUPPLEMENTAL RESTRAINT SYSTEM (SRS) EQUIPPED VEHICLES

WARNING!

- (1) Improper service or maintenance of any component of the SRS, or any SRS-related component, can lead to personal injury or death to service personnel (from inadvertent firing of the air bag) or to the driver (from rendering the SRS inoperative).
- (2) Service or maintenance of any SRS component or SRS-related component must be performed only at an authorized MITSUBISHI dealer.
- (3) MITSUBISHI dealer personnel must thoroughly review this manual, and especially its GROUP 52B – Supplemental Restraint System (SRS) before beginning any service or maintenance of any component of the SRS or any SRS-related component.

NOTE

The SRS includes the following components: front impact sensors, SRS-ECU, SRS warning lamp, air bag module, clock spring and interconnecting wiring. Other SRS-related components (that may have to be removed/installed in connection with SRS service or maintenance) are indicated in the table of contents by an asterisk (*).

SERVICE SPECIFICATIONS

Items		Standard value	
		Sport seat	Except sport seat
Seat cushion heater resistance Ω (at cabin temperature of 20°C)	Between terminals 1 and 3	6.4±10%	5.0 ± 10%
	Between terminals 2 and 3	6.0±10%	5.4 ± 10%
Seatback heater resistance Ω (at cabin temperature of 20°C)	Between terminals 1 and 2	6.0±10%	6.0 ± 10%

SPECIAL TOOL

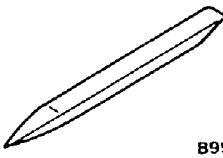



Tool	Number	Name	Use
 <p>8990784</p>	MB990784	Ornament remover	Removal of switch, trim, etc.

INSTRUMENT PANEL <L.H. DRIVE VEHICLES>**Caution**

For removal of instrument panel and the passenger's side air bag module, always observe the service procedures described in GROUP 52B – Air Bag Module and Clock Spring.

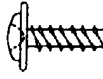
REMOVAL AND INSTALLATION

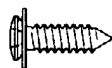
For installation of the instrument panel, the bolts and screws described below are used. They are indicated by symbols in the illustration.

Name	Symbol	Size mm (D x L)	Colour	Shape
Tapping screw	A	5 x 10	–	 19Z0004
	B	5 x 12	–	
	C	5 x 16	–	 19Z0022
	D	5 x 16	–	
	E	5 x 16	Black	
	F	5 x 20	–	
	G	5 x 20	Black	
	H	5 x 16	–	 19Z0003
Washer assembled screw	I	5 x 16	–	 X0010BY
Washer assembled bolt	J	5 x 20	Black	 19Z0005
	K	6 x 16	–	
	L	6 x 16	Black	
	M	6 x 20	–	 19Z0010

D = Thread diameter

L = Effective thread length

CAUTION: SRS

When removing and installing the instrument panel (vehicles equipped with SRS), do not let it bump against the SRS-ECU.

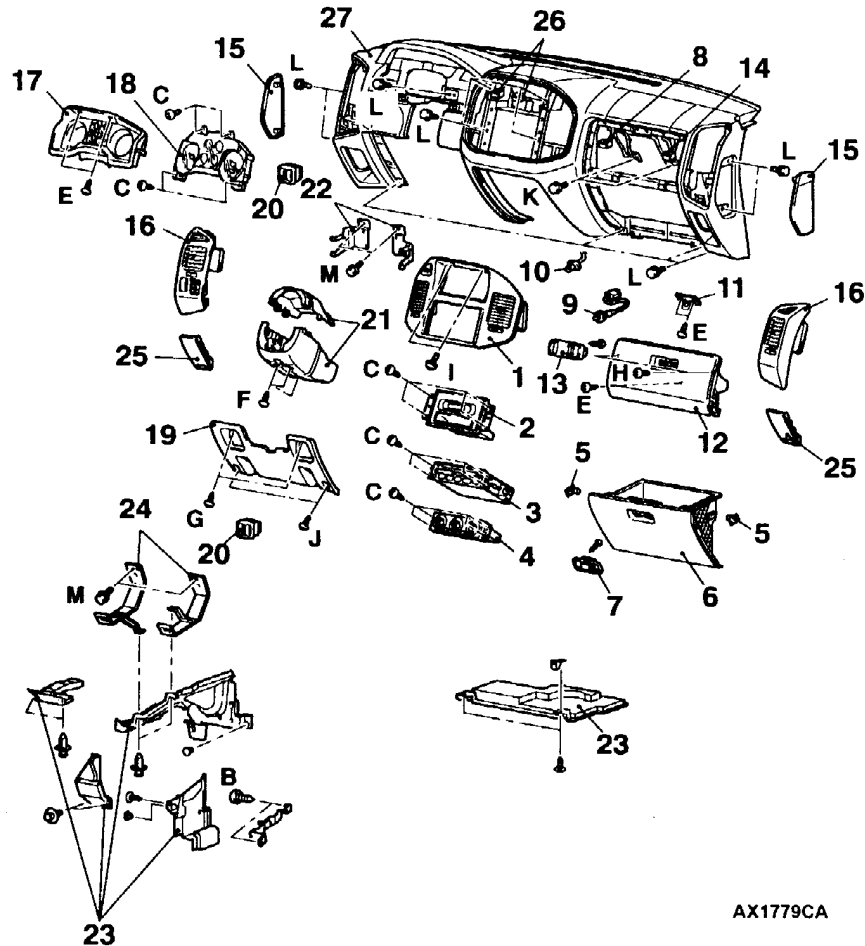

AX1779CA

Removal steps

- Rear floor console assembly (Refer to P.52A-12.)
- CD player unit (Refer to GROUP 54A.)
- Front floor console (Refer to P.52A-12.)
- 1. Center panel assembly
- 2. Center display
- 3. Radio and tape player
- 4. Manual air conditioner assembly
- 5. Glove box stopper
- 6. Glove box assembly
- 7. Glove box lock
- 8. Glove box lamp switch harness connector
- 9. Glove box lamp switch
- 10. Glove box lamp
- 11. Upper glove box striker
- 12. Upper glove box assembly
- 13. Upper glove box lid lock
- 14. Front passenger's side air bag module harness connector
- 15. Instrument panel side cover
- 16. Air outlet assembly
- 17. Meter bezel
- 18. Combination meter assembly
 - Hood opener lever (Refer to GROUP 42.)
 - Fuel lid opener lever (Refer to GROUP 42.)
- 19. Lower panel
- 20. Switch panel
- 21. Column cover
- 22. Stay A
 - Assist grip (Refer to P.52A-13,15.)
 - Front pillar trim (Refer to P.52A-13,15.)
- 23. Under cover assembly
- 24. Stay B
- 25. Corner lower panel
- 26. Photo sensor harness connector
 - Steering shaft assembly bolt (Refer to GROUP 37A.)
- 27. Instrument panel assembly

CLIP AND CLAW POSITION

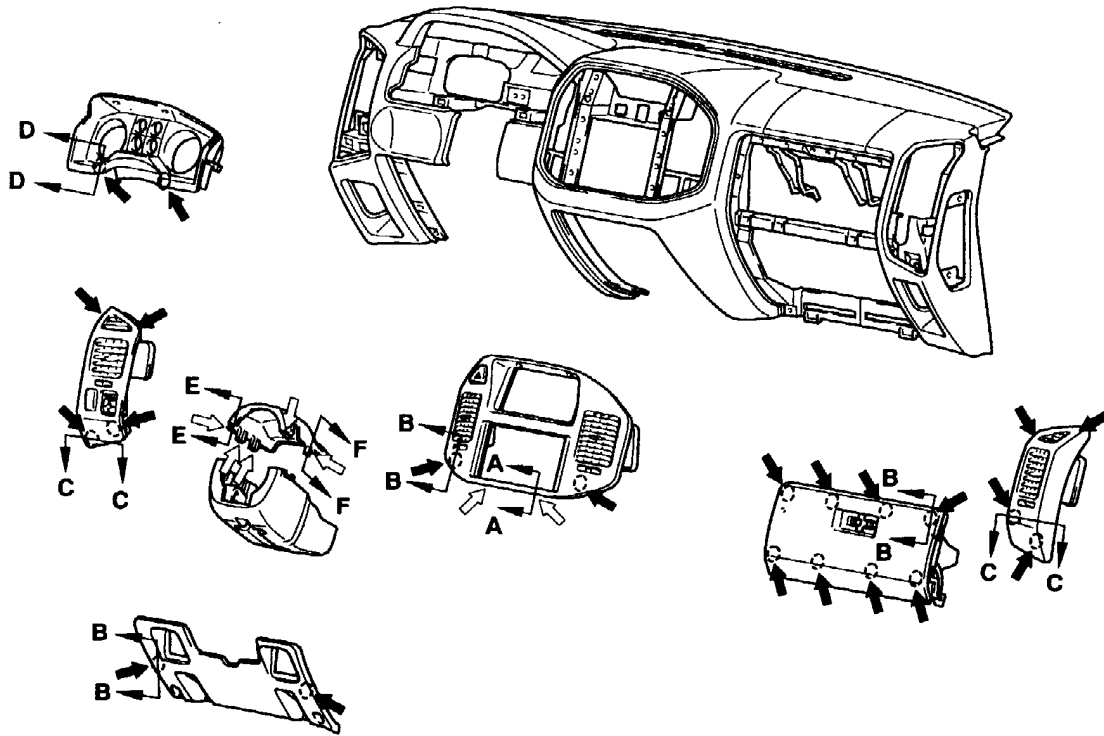

NOTE

- ➔ : Clip position
- ➞ : Claw position

AACX01533

<p>Section A - A</p> <p>Center panel assembly</p> <p>Instrument panel</p> <p>Claw</p> <p>AACX01367</p>	<p>Section B - B</p> <p>Instrument panel</p> <p>Center panel assembly and upper glove box assembly and lower panel</p> <p>Clip</p> <p>AACX01368</p>	<p>Section C - C</p> <p>Air outlet assembly</p> <p>Clip</p> <p>Instrument panel</p> <p>AACX01366</p>	<p>Section D - D</p> <p>Meter bezel</p> <p>Instrument panel</p> <p>Clip</p> <p>AACX01369</p>
<p>Section E - E</p> <p>Column cover</p> <p>Claw</p> <p>AACX01365</p>	<p>Section F - F</p> <p>Column cover</p> <p>Claw</p> <p>AACX01364</p>		

DISASSEMBLY AND REASSEMBLY

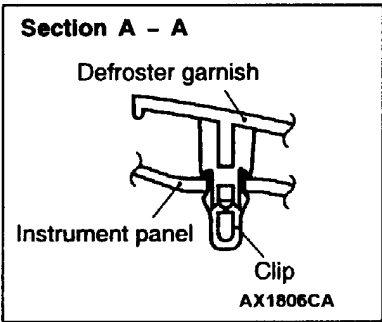
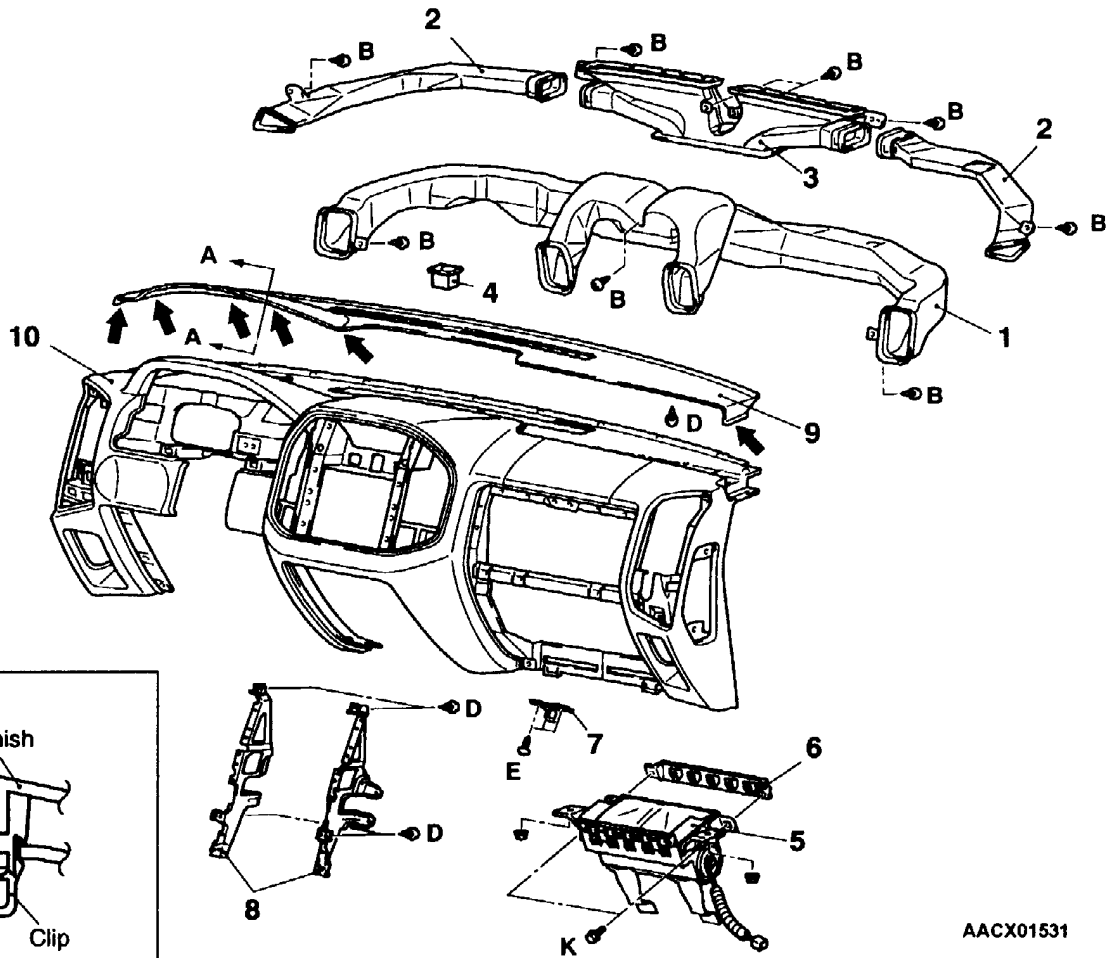

AACX01531

Disassembly steps





- | | |
|--|--|
| 1. Distribution duct | 6. Air bag side plate |
| 2. Side defroster duct | 7. Glove box striker |
| 3. Center defroster duct | 8. Instrument panel center reinforcement |
| 4. Photo sensor | 9. Defroster garnish |
| 5. Front passenger's side air bag module | 10. Instrument panel |

INSTRUMENT PANEL <R.H. DRIVE VEHICLES>**Caution**

For removal of instrument panel and the passenger's side air bag module, always observe the service procedures described in GROUP 52B - Air Bag Module and Clock Spring.

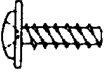
REMOVAL AND INSTALLATION

For installation of the instrument panel, the bolts and screws described below are used. They are indicated by symbols in the illustration.

Name	Symbol	Size mm (D x L)	Colour	Shape
Tapping screw	a	5 x 10	-	 19Z0004
	b	5 x 12	-	
	c	5 x 16	-	 19Z0022
	d	5 x 16	-	
	e	5 x 16	Black	
	f	5 x 20	-	
	g	5 x 20	Black	 19Z0003
	h	5 x 16	-	
Washer assembled screw	i	5 x 16	-	 X0010BY
Washer assembled bolt	j	5 x 20	Black	 19Z0005
	k	6 x 16	-	
	l	6 x 16	Black	
	m	6 x 20	-	 19Z0010

D = Thread diameter

L = Effective thread length

CAUTION: SRS
When removing and installing the instrument panel (vehicles equipped with SRS), do not let it bump against the SRS-ECU.

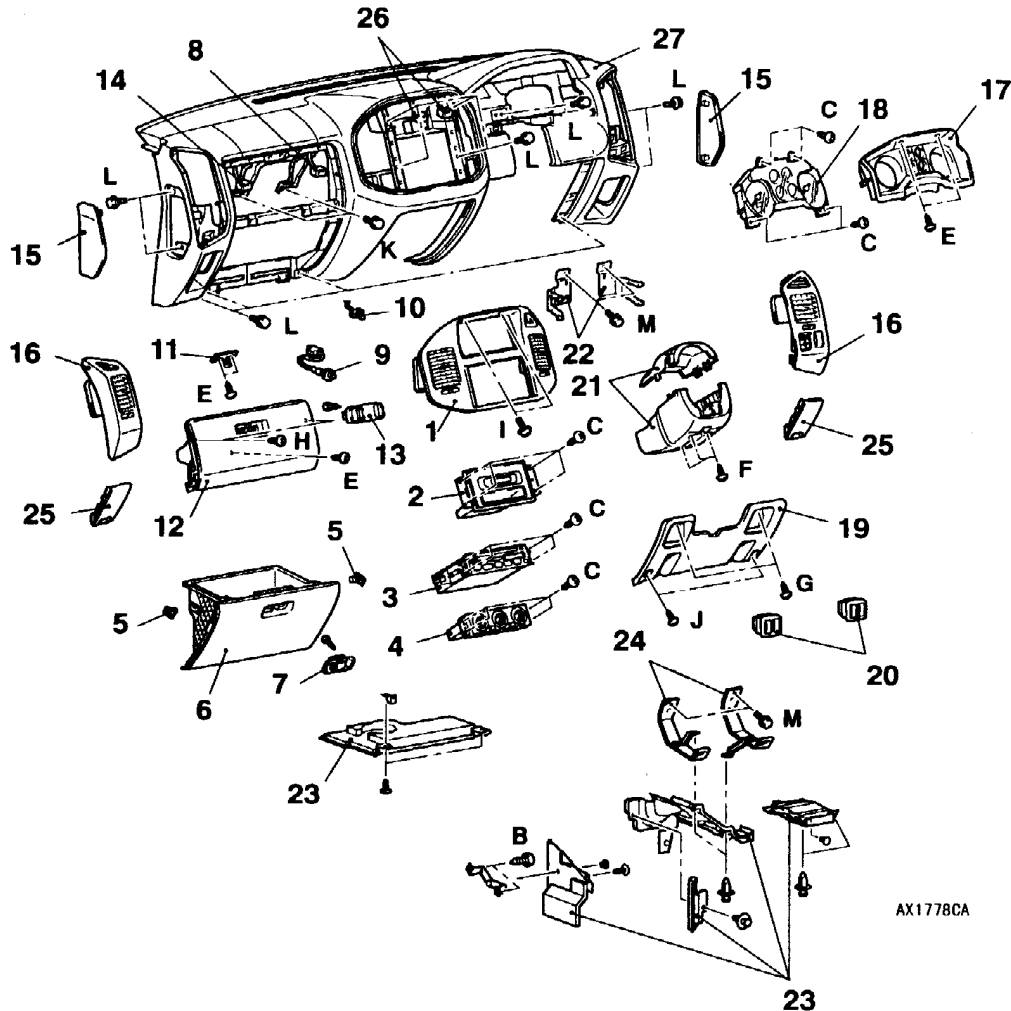

AX1778CA

Removal steps

- Rear floor console assembly (Refer to P.52A-12.)
- CD player unit (Refer to GROUP 54A.)
- Front floor console (Refer to P.52A-12.)
- 1. Center panel assembly
- 2. Center display
- 3. Radio and tape player
- 4. Manual air conditioner assembly
- 5. Glove box stopper
- 6. Glove box assembly
- 7. Glove box lock
- 8. Glove box lamp switch harness connector
- 9. Glove box lamp switch
- 10. Glove box lamp
- 11. Upper glove box striker
- 12. Upper glove box assembly
- 13. Upper glove box lid lock
- 14. Front passenger's side air bag module harness connector
- 15. Instrument panel side cover
- 16. Air outlet assembly
- 17. Meter bezel
- 18. Combination meter assembly
 - Hood opener lever (Refer to GROUP 42.)
 - Fuel lid opener lever (Refer to GROUP 42.)
- 19. Lower panel
- 20. Switch panel
- 21. Column cover
- 22. Stay A
 - Assist grip (Refer to P.52A-13,15.)
 - Front pillar trim (Refer to P.52A-13,15.)
- 23. Under cover assembly
- 24. Stay B
- 25. Corner lower panel
- 26. Photo sensor harness connector
 - Steering shaft assembly bolt (Refer to GROUP 37A.)
- 27. Instrument panel assembly

CLIP AND CLAW POSITION

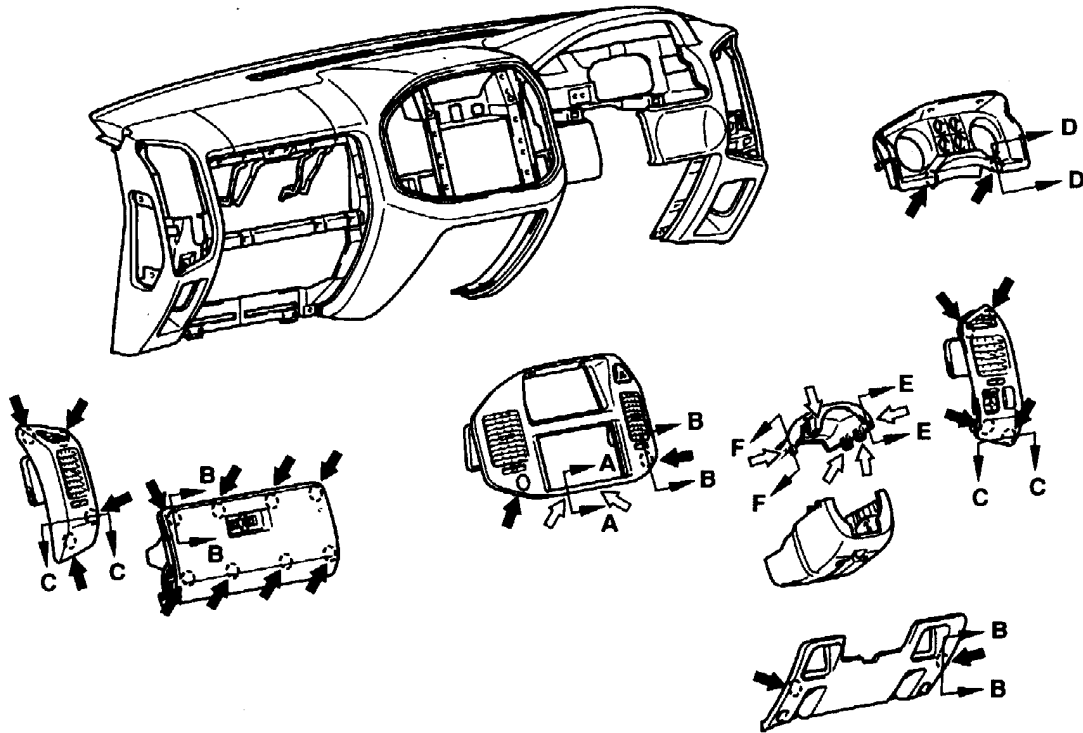

NOTE
 ← : Clip position
 ⇐ : Claw position

AX0873CA

<p>Section A - A</p> <p>Claw Center panel assembly Instrument panel AX0617CA</p>	<p>Section B - B</p> <p>Instrument panel Clip BW0627AQ Center panel assembly and upper glove box assembly and lower panel</p>	<p>Section C - C</p> <p>Clip Instrument panel AX0618CA Air outlet assembly</p>	<p>Section D - D</p> <p>Clip Instrument panel Meter bezel BV0786AE</p>
<p>Section E - E</p> <p>Claw Column cover AX0615CA</p>	<p>Section F - F</p> <p>Claw Column cover AX0614CA</p>		

DISASSEMBLY AND REASSEMBLY

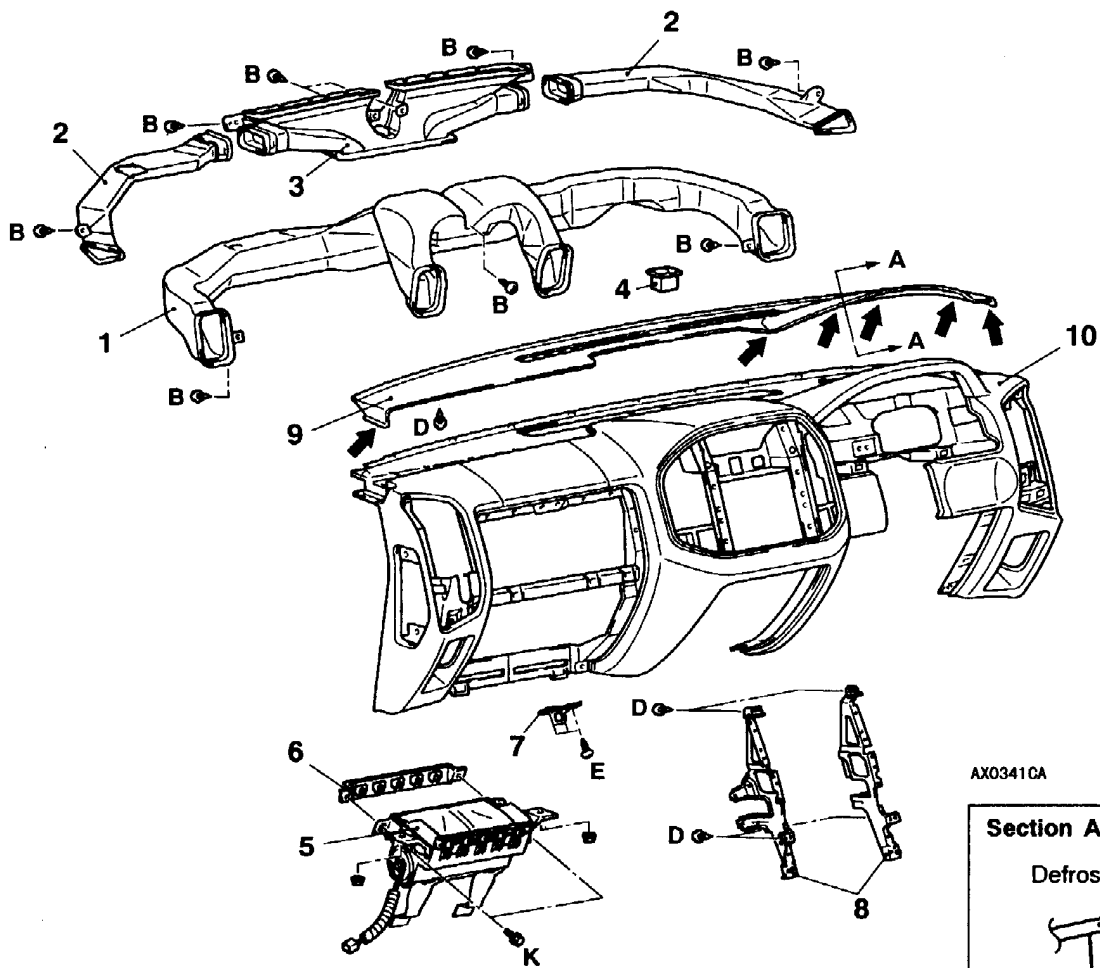

AX0341GA

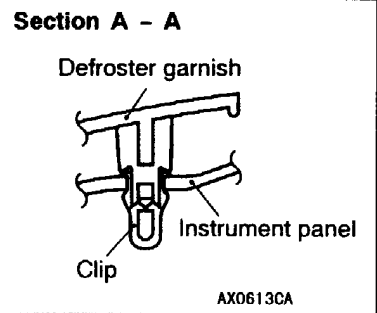

Disassembly steps

1. Distribution duct
2. Side defroster duct
3. Center defroster duct
4. Photo sensor
5. Front passenger's side air bag module

6. Air bag side plate
7. Glove box striker
8. Instrument panel center reinforcement
9. Defroster garnish
10. Instrument panel

TRIMS

REMOVAL AND INSTALLATION

<Short Wheelbase>

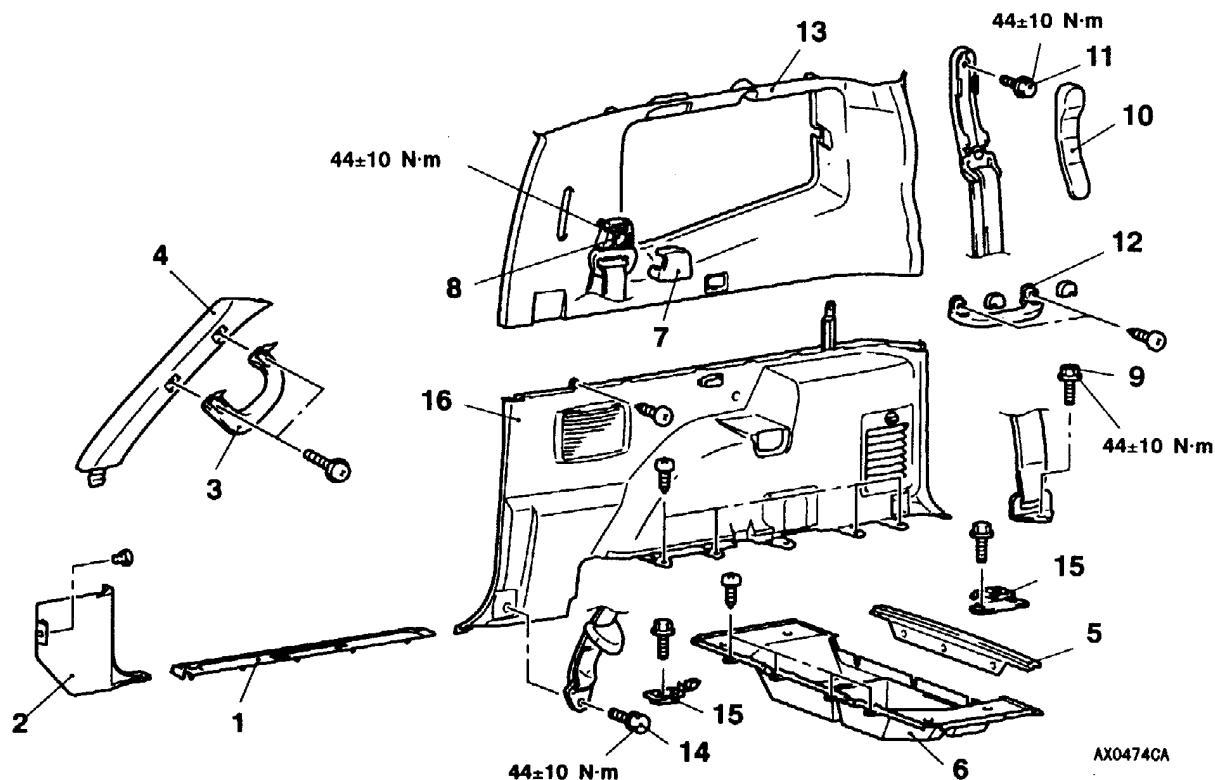

NOTE

For door trims, refer to GROUP 42.

- | | |
|-------------------------------|--------------------------------|
| 1. Front scuff plate | 9. Rear seat belt connection |
| 2. Cowl side trim | 10. Sash guide cover |
| 3. Assist grip | 11. Rear seat belt connection |
| 4. Front pillar trim | 12. Assist grip |
| 5. Back door scuff plate | 13. Quarter trim, upper |
| 6. Luggage floor box | 14. Front seat belt connection |
| 7. Sash guide cover | 15. Luggage hook |
| 8. Front seat belt connection | 16. Quarter trim, lower |

CLIP AND CLAW POSITION

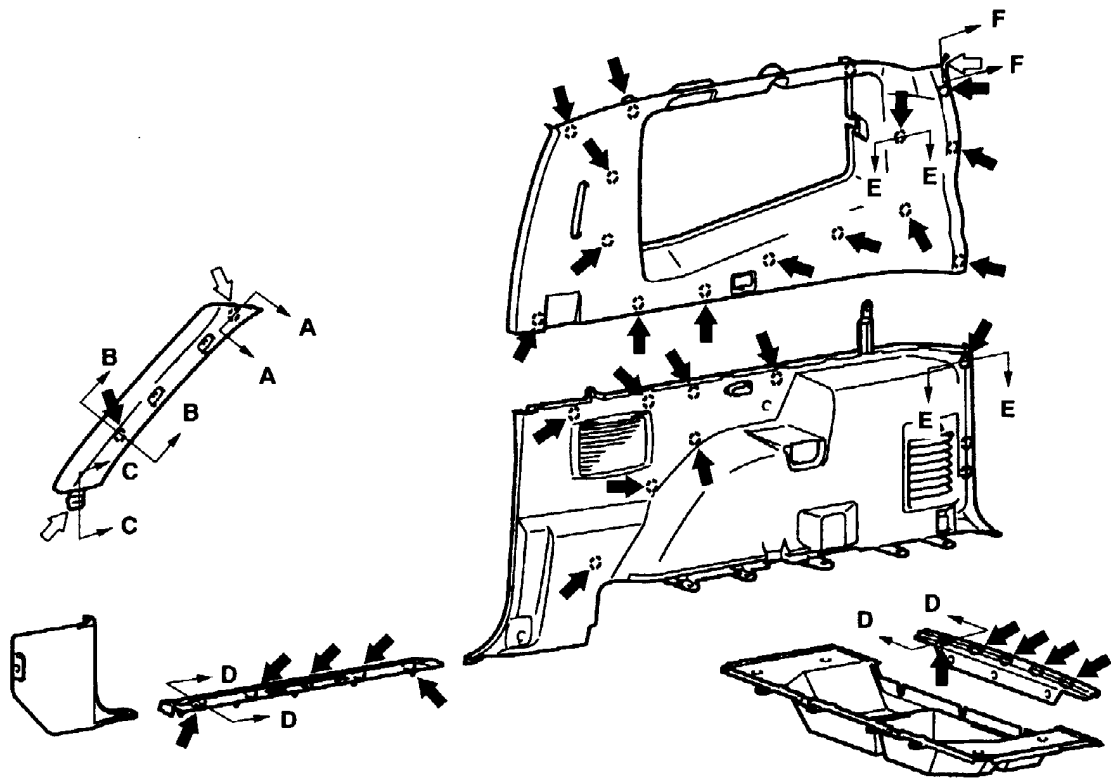

AX0478CA

NOTE

- ◄ : Clip position
- ◁ : Claw position

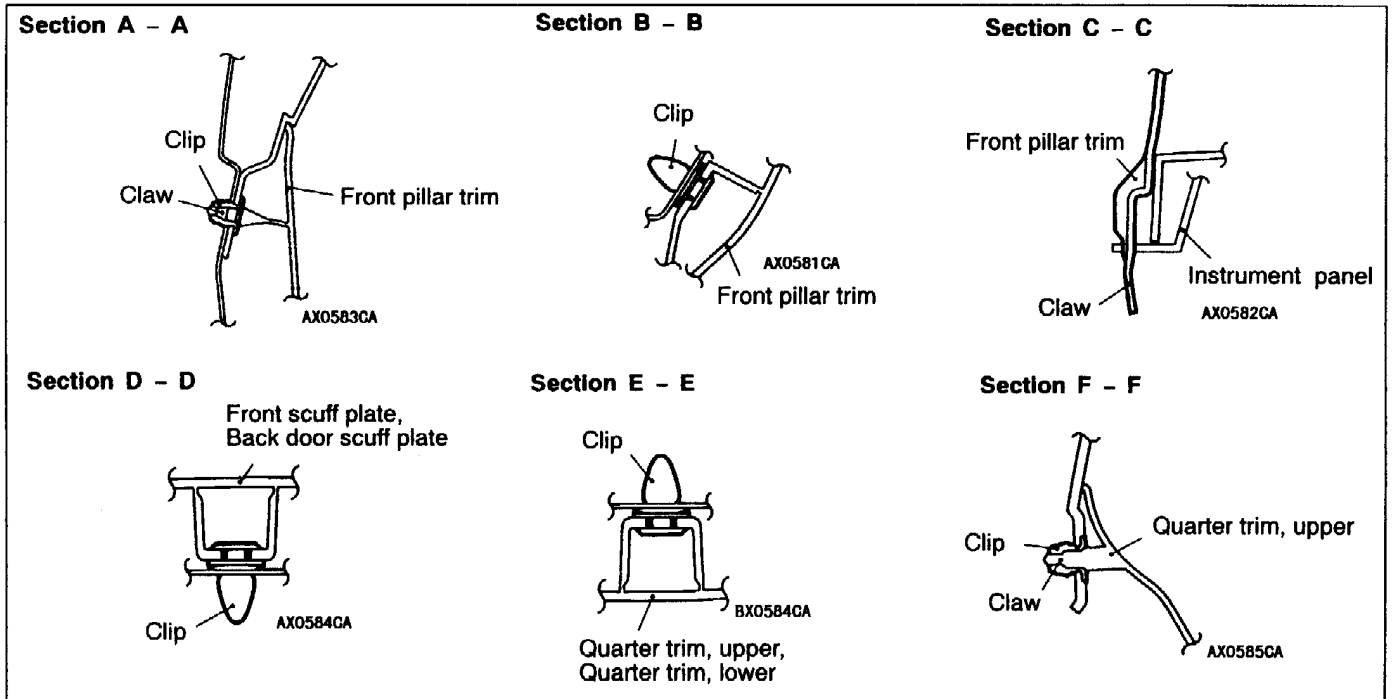

<Long Wheelbase>

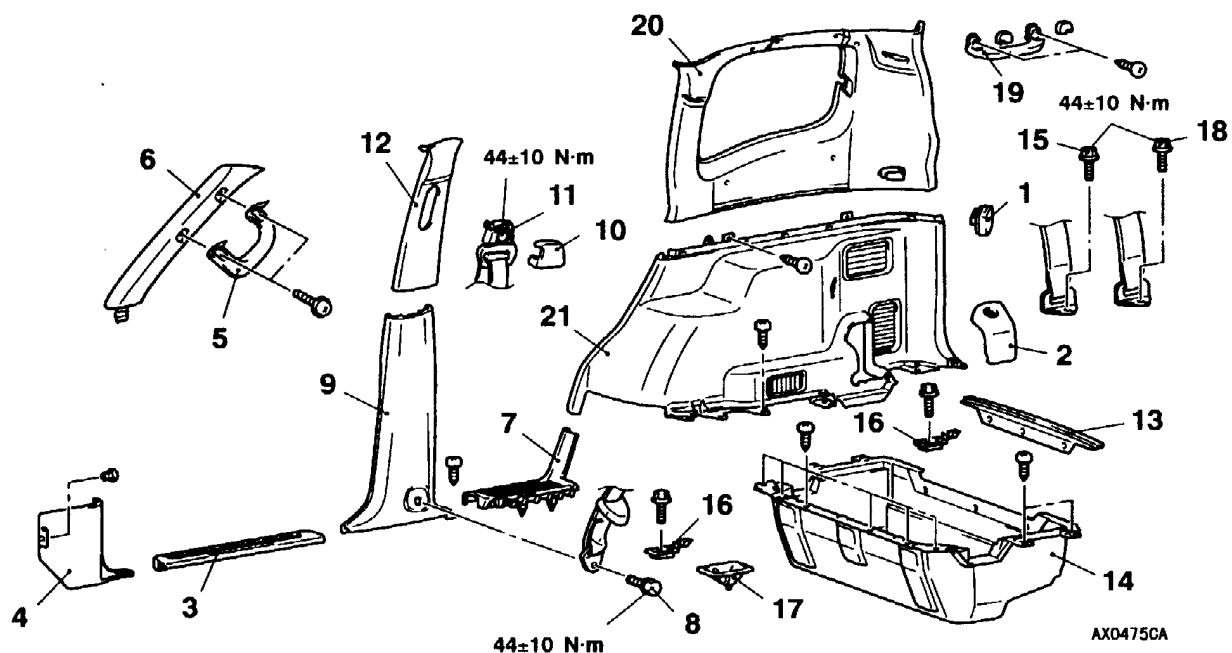

NOTE
For door trims, refer to GROUP 42.

- | | |
|-------------------------------|---------------------------------|
| 1. AC socket | 11. Front seat belt connection |
| 2. Quarter trim cover | 12. Center pillar trim, upper |
| ● Third seat assembly | 13. Back door scuff plate |
| 3. Front scuff plate | 14. Luggage floor box |
| 4. Cowl side trim | 15. Second seat belt connection |
| 5. Assist grip | 16. Luggage hook |
| 6. Front pillar trim | 17. Striker cover |
| 7. Rear scuff plate | 18. Third seat belt connection |
| 8. Front seat belt connection | 19. Assist grip |
| 9. Center pillar trim, lower | 20. Quarter trim, upper |
| 10. Sash guide cover | 21. Quarter trim, lower |

CLIP AND CLAW POSITION

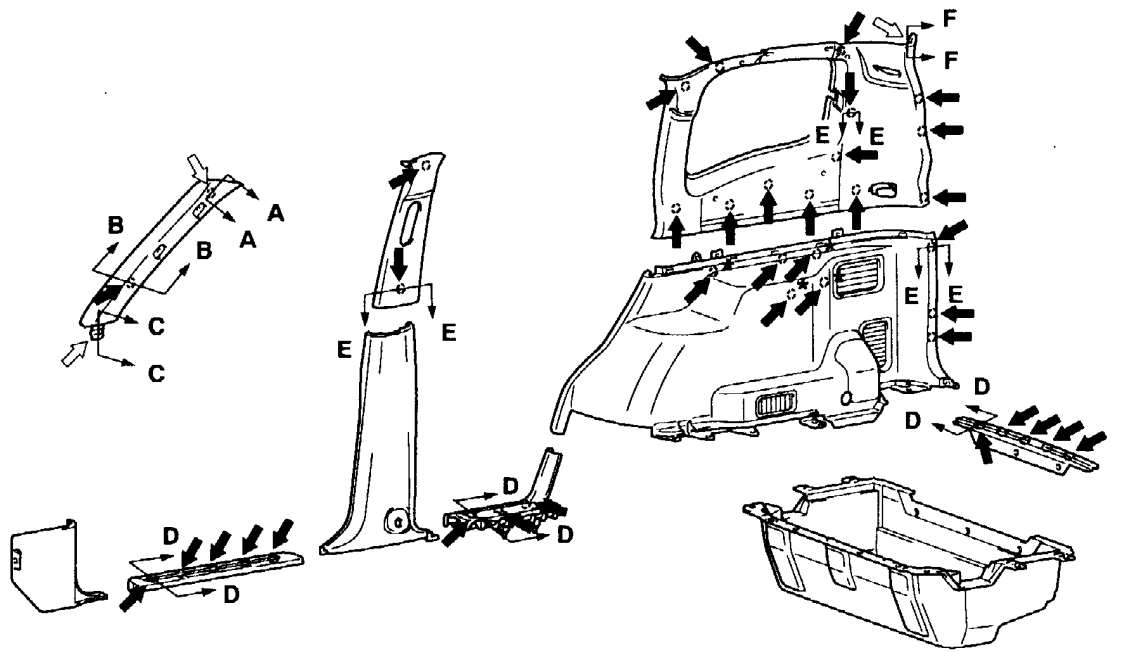

AX1844CA

NOTE

◄ : Clip position (* mark shows L.H. side only)
 ◄ : Claw position

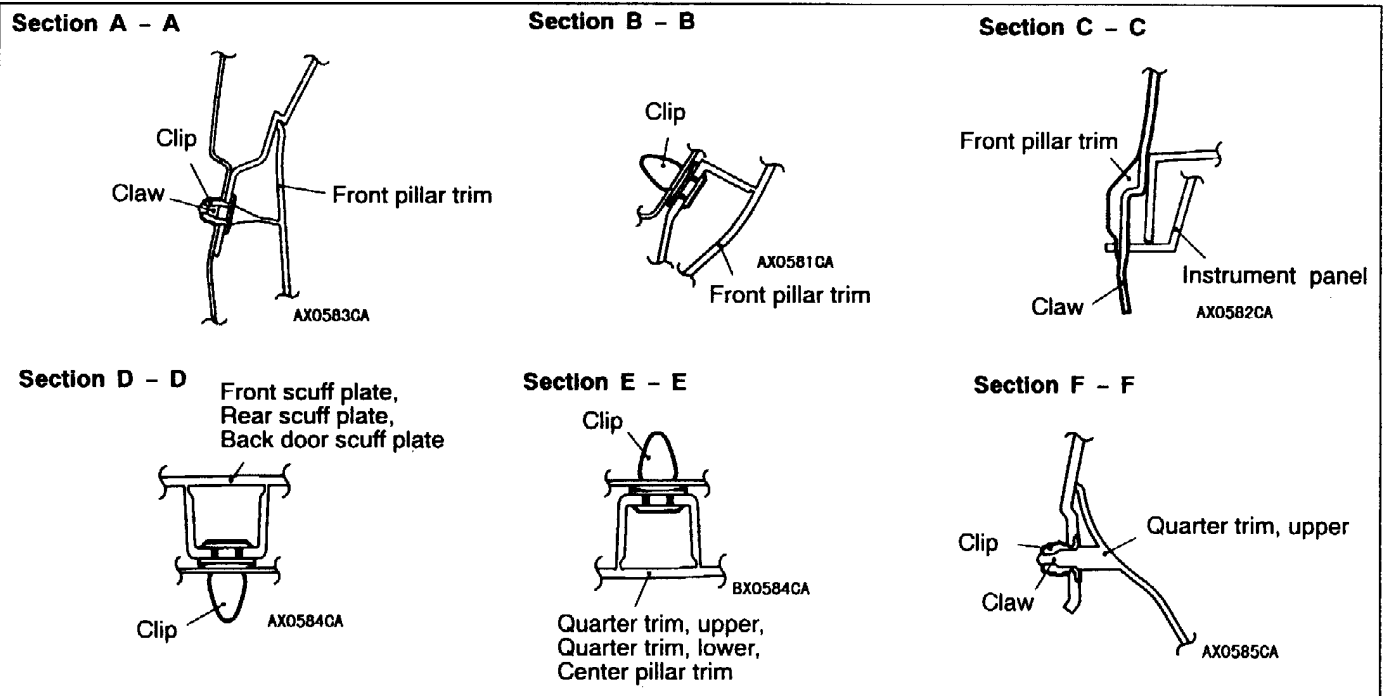

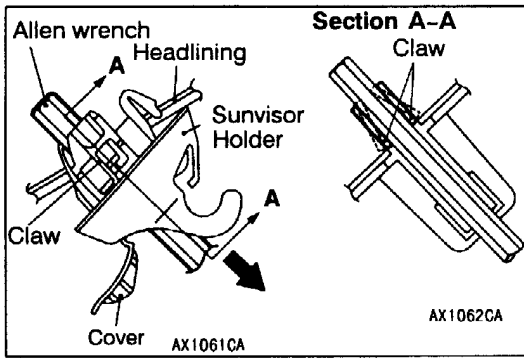

SUNVISOR HOLDER

REMOVAL SERVICE POINT

SUNVISOR HOLDER REMOVAL

1. Remove the sunvisor holder cover, insert a 6 mm-Allen wrench to disengage the sunvisor holder side claws.
2. Pull out the sunvisor into the shown direction to remove the sunvisor holder.

FRONT SEAT

REMOVAL AND INSTALLATION

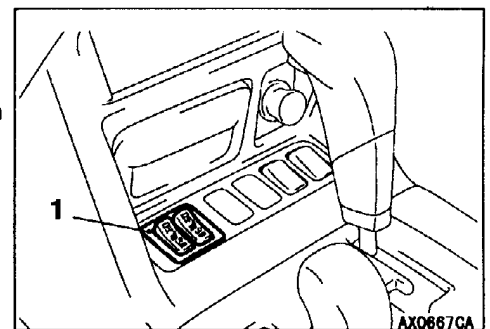
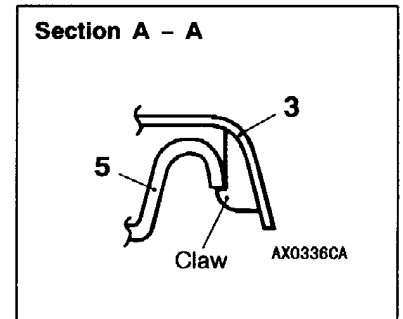
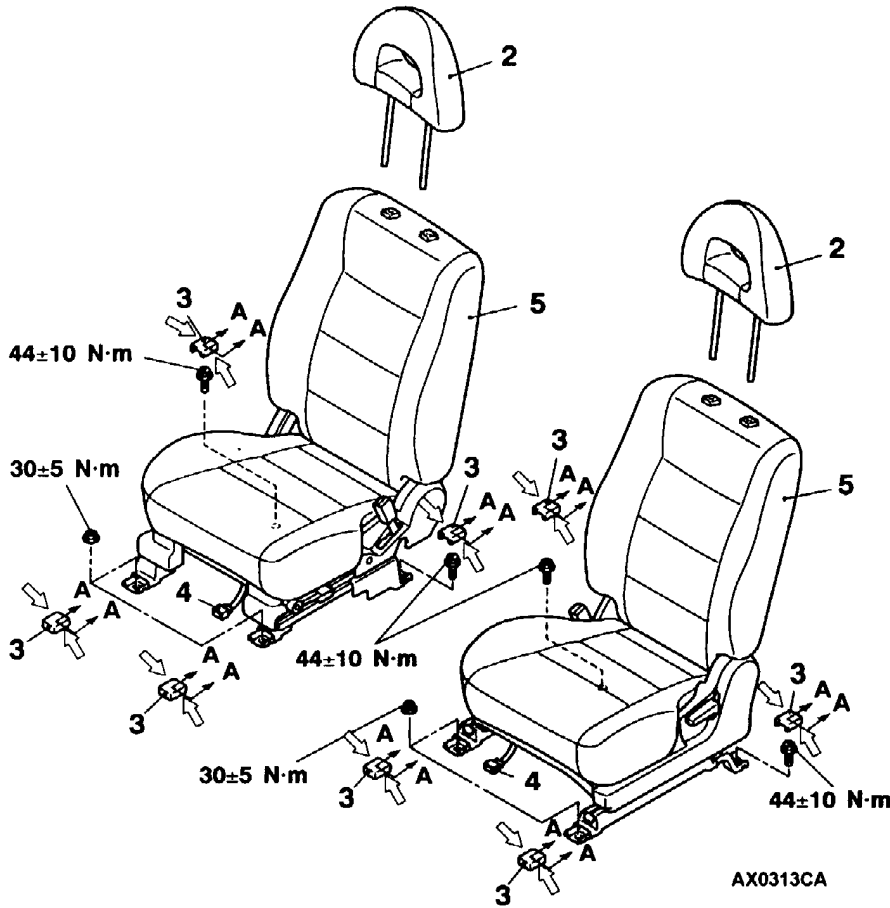

NOTE:
 ↔ marks show claw positions.

- 1. Heated seat switch
- 2. Headrest

Front seat assembly removal steps

- 3. Front seat anchor cover
- 4. Harness connector
- 5. Front seat assembly

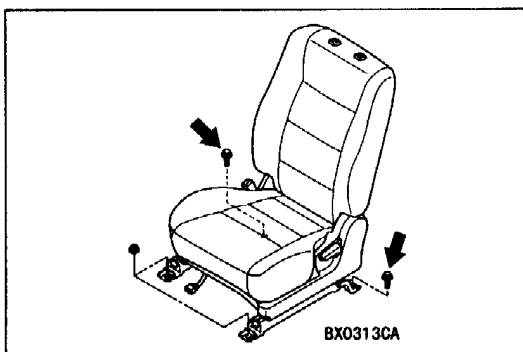

INSTALLATION SERVICE POINT

▶◀ FRONT SEAT ASSEMBLY INSTALLATION

First install all of the front seat assembly mounting nuts and bolts, and then tighten them to the specified torque. The shown bolts should be tightened with no load applied to the front seat cushion.

DISASSEMBLY AND REASSEMBLY

<Power seat>

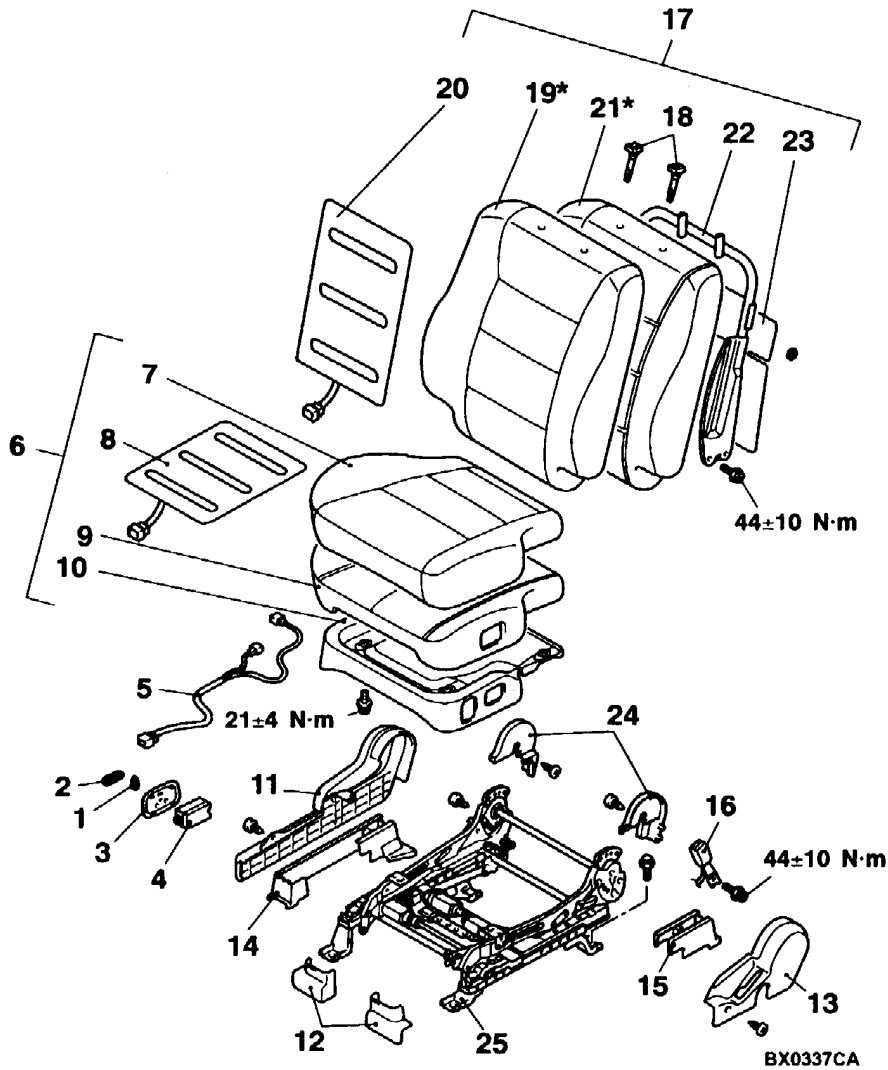

NOTE

*: For the sport seat, the seat cover and pad are non-separable.

Disassembly steps

- | | | |
|--|-----------|---|
| <ol style="list-style-type: none"> 1. Reclining adjuster knob 2. Slide adjuster knob 3. Power seat switch garnish 4. Power seat switch 5. Harness clamp 6. Front seat cushion assembly 7. Front seat cushion cover 8. Front seat cushion heater 9. Front seat cushion pad 10. Front seat cushion frame 11. Side shield cover 12. Front rail cover 13. Hinge cover | <p>◀▶</p> | <ol style="list-style-type: none"> 14. Seat slide adjuster side cover 15. Seat slide adjuster inner side cover 16. Inner seat belt 17. Front seat back assembly 18. Headrest guide 19. Front seatback cover 20. Front seatback heater 21. Front seatback pad 22. Front seatback frame 23. Front seatback board 24. Reclining adjuster lower cover 25. Seat slide adjuster |
|--|-----------|---|

BX0337CA

<Except power seat>

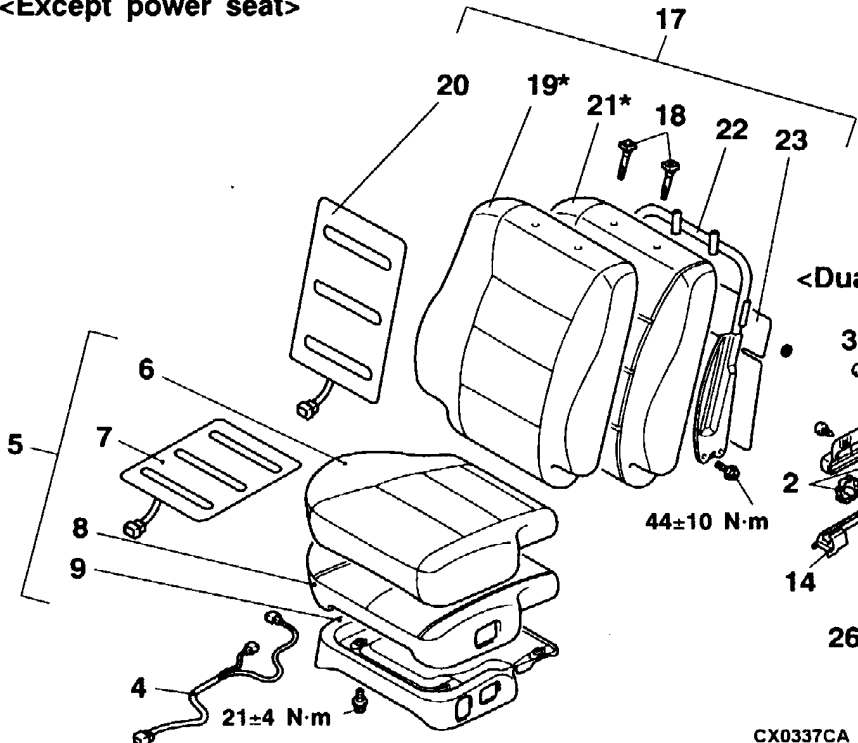

<Dual height adjuster seat>

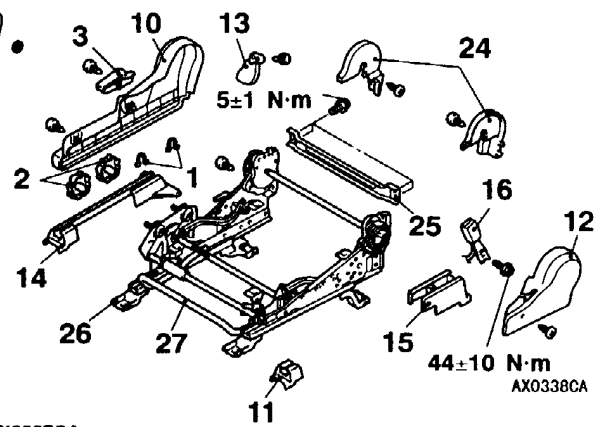

<Suspension seat>

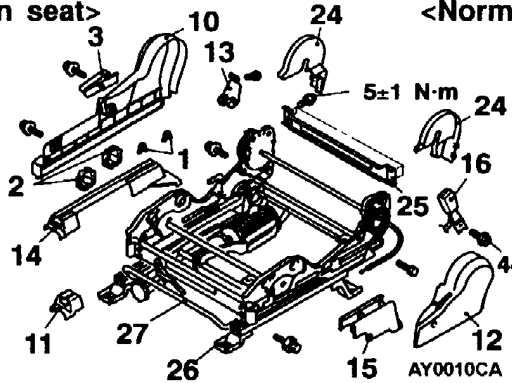

<Normal seat>

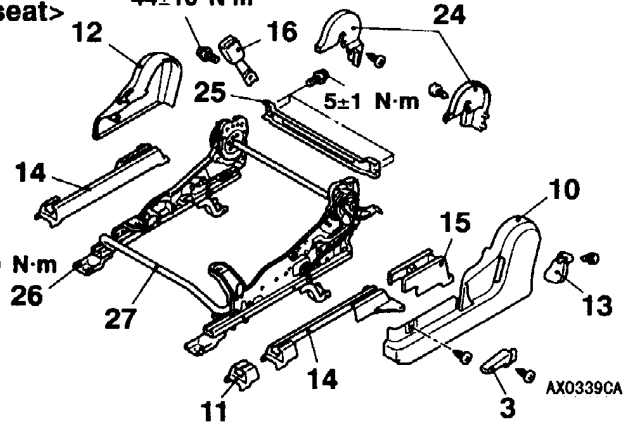

NOTE

*: For the sport seat, the seat cover and pad are non-separable.

Disassembly steps

1. Clip<Vehicles with Suspension seat and dual height adjuster seat>
2. Height adjuster knob<Vehicles with Suspension seat and dual height adjuster seat>
3. Reclining adjuster lever
4. Harness clamp
5. Front seat cushion assembly
6. Front seat cushion cover
7. Front seat cushion heater
8. Front seat cushion pad
9. Front seat cushion frame
10. Side shield cover
11. Front rail cover
12. Hinge cover
13. Rear rail cover



14. Seat slide adjuster side cover
15. Seat slide adjuster inner side cover
16. Inner seat belt
17. Front seat back assembly
18. Headrest guide
19. Front seatback cover
20. Front seatback heater
21. Front seatback pad
22. Front seatback frame
- <Vehicles without side air bag>
23. Front seat back board
24. Reclining adjuster lower cover
25. Front seat frame
26. Seat slide adjuster
27. Seat slide adjuster lever

CLIP AND CLAW POSITION

<Side shield cover>

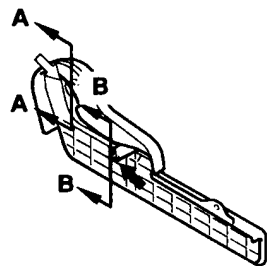

ACX01394

Section A - A

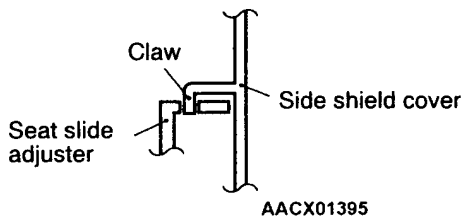

AACX01395

Section B - B

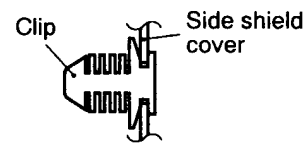

AACX01396

<Front rail cover>

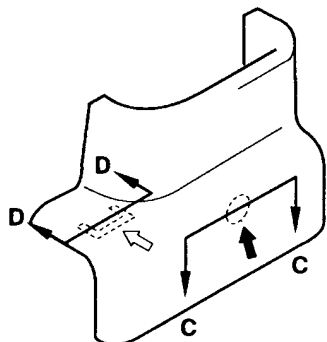

ACX01397

Section C - C

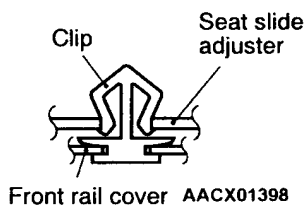

AACX01398

Section D - D

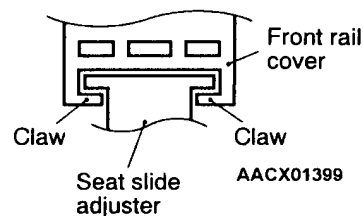

AACX01399

<Hinge cover>

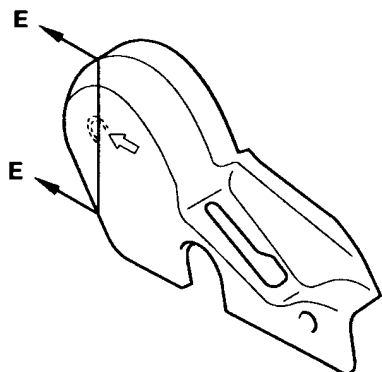

ACX01400

Section E - E

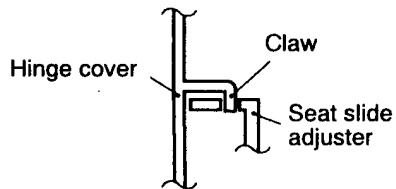

AACX01401

<Reclining adjuster lower cover>

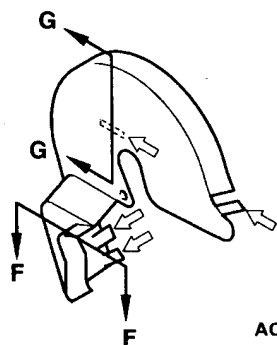

ACX01402

Section F - F

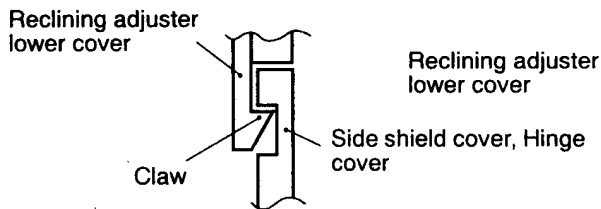

AACX01403

Section G - G

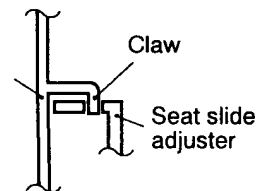

AACX01401

NOTE

- ◀ : Clip position
- ◁ : Claw position

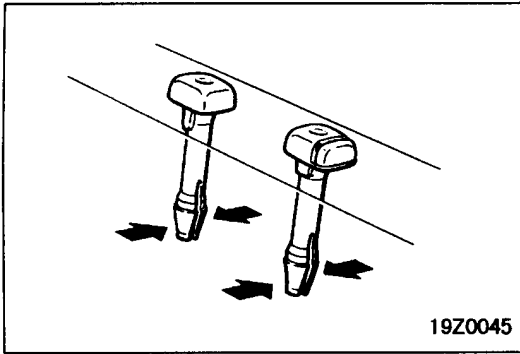

REMOVAL SERVICE POINT

◀A▶ HEADRESTRAINT GUIDE REMOVAL

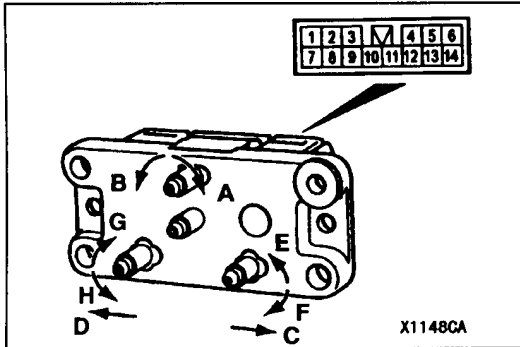

INSPECTION

POWER SEAT MANUAL SWITCH CONTINUITY CHECK

Switch position			Terminal No.										
			1	2	3	4	5	6	7	8	13	14	
Reclining switch	Front	A			○	○						○	○
	Rear	B			○	○						○	○
Slide switch	Front	C							○	○	○	○	○
	Rear	D							○	○	○	○	○
Front height switch	Up	E	○	○								○	○
	Down	F	○	○								○	○
Rear height switch	Up	G					○	○				○	○
	Down	H					○	○				○	○

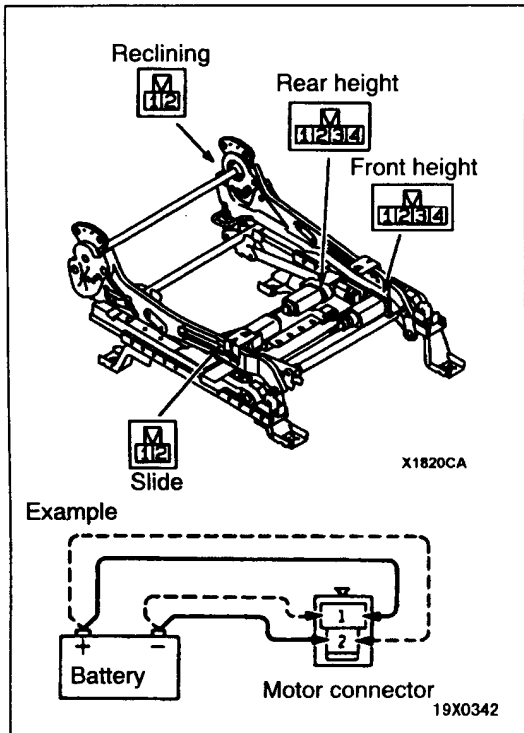

POWER SEAT SWITCH FUNCTION CHECK

1. Disconnect the motor connectors.
2. When the battery voltage is applied to the motor terminals, each motor should run smoothly and the seat adjusting mechanism should meet the table below.

Motor name	Function direction	Terminal No.				Stop position
		1	2	3	4	
Front height	Down	⊕	⊖	-	-	Should stop at pre-determined limit position.
	Up	⊖	⊕	-	-	
Rear height	Down	-	-	⊕	⊖	
	Up	-	-	⊖	⊕	
Slide	Rear	⊕	⊖	-	-	
	Front	⊖	⊕	-	-	
Reclining	Rear	⊖	⊕	-	-	
	Front	⊕	⊖	-	-	

3. If defective, check the power seat adjuster assembly.

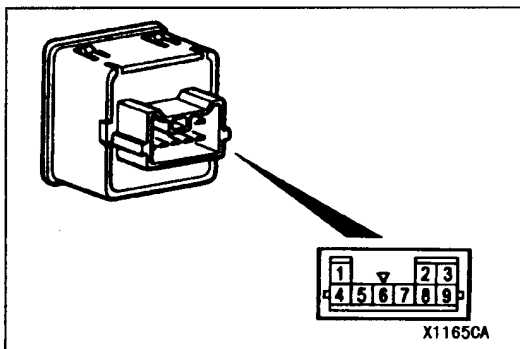

HEATED SEAT SWITCH CONTINUITY CHECK

	Switch position	1	3	4	5	IND	8	9	2	6
Driver's side	HI			○	⊕	⊕	⊖	○	ILL	
	OFF				○			○		
	LO				⊕	⊕	⊖	○		
Passenger's side	HI	○	○		⊕	⊕	⊖			
	OFF				○			○		
	LO		○		⊕	⊕	⊖			

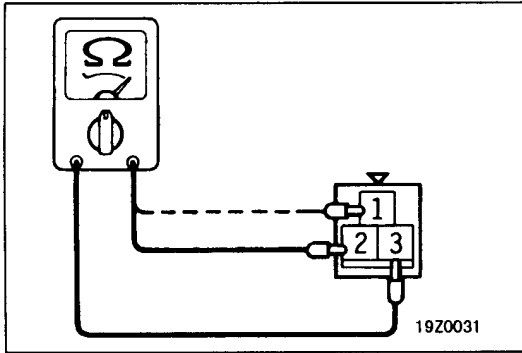
**SEAT CUSHION HEATER CHECK**

Measure the resistance between terminals.

Standard value (at cabin temperature of 20°C):

Terminal No.	Sport seat	Except sport seat
Between terminals 1–3	6.0Ω±10%	5.0Ω±10%
Between terminals 2–3	6.4Ω±10%	5.4Ω±10%

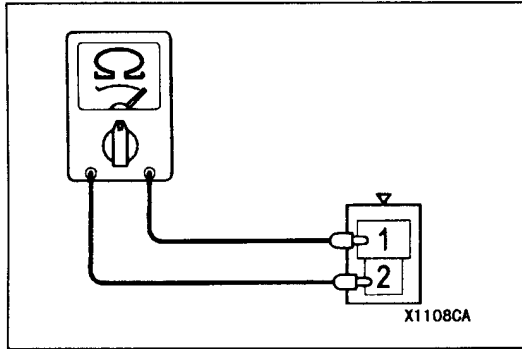
**SEATBACK HEATER CHECK**

Measure the resistance between terminals.

Standard value (at cabin temperature of 20°C):

Terminal No.	Sport seat	Except sport seat
Between terminals 1–2	6.0Ω±10%	6.0Ω±10%

**REAR/SECOND SEAT
REMOVAL AND INSTALLATION**

<Short wheelbase>

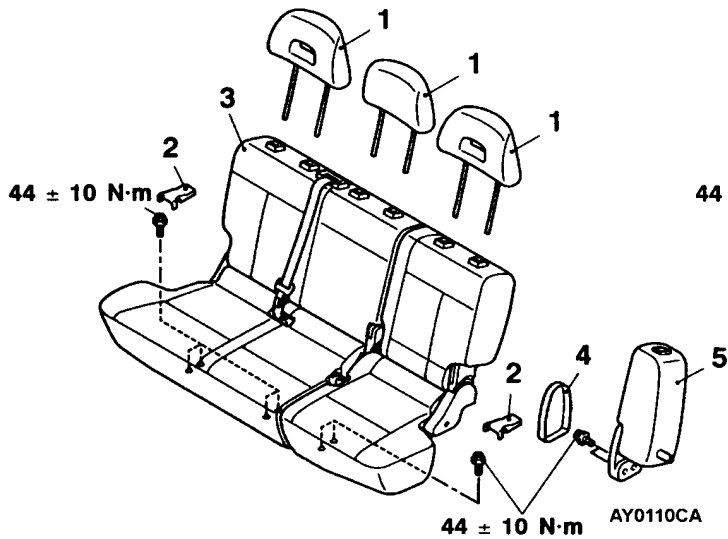

<Long wheelbase>

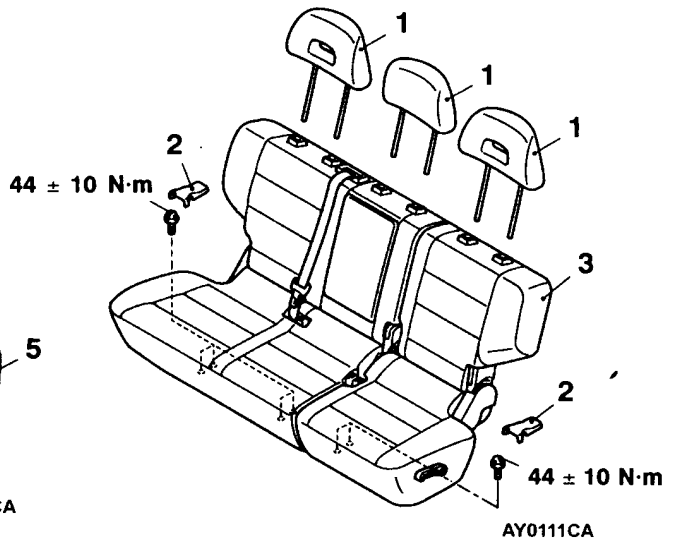

1. Headrest

Rear/second seat assembly removal steps

2. Seat anchor cover
3. Rear/second seat assembly

Seat side back assembly removal steps

4. Seat hinge cover
5. Seat side back assembly

CLAW POSITION

<Seat anchor cover>

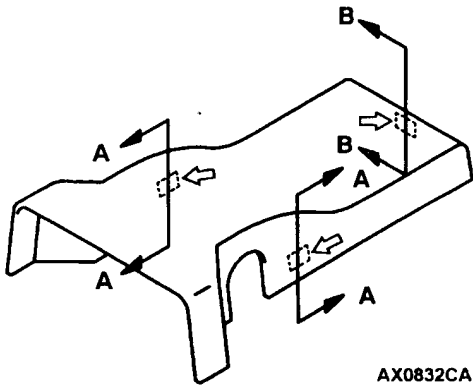

Section A - A

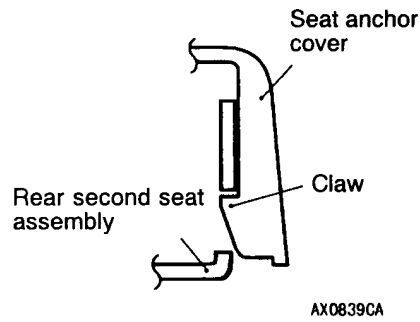

Section B - B

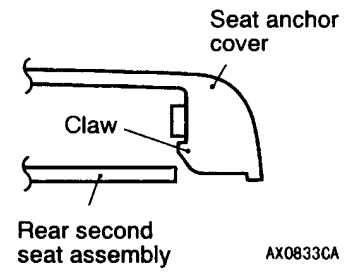

<Front rail cover>

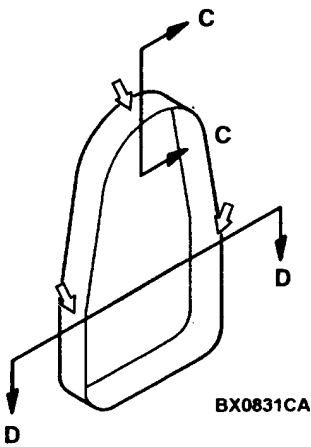

Section C - C

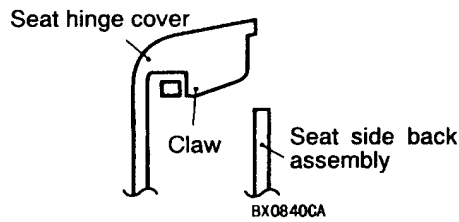

Section D - D

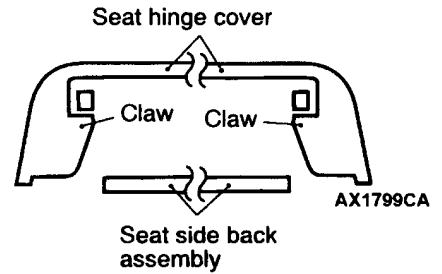

NOTE

↔ : Claw position

DISASSEMBLY AND REASSEMBLY

<Short wheelbase L.H. side>

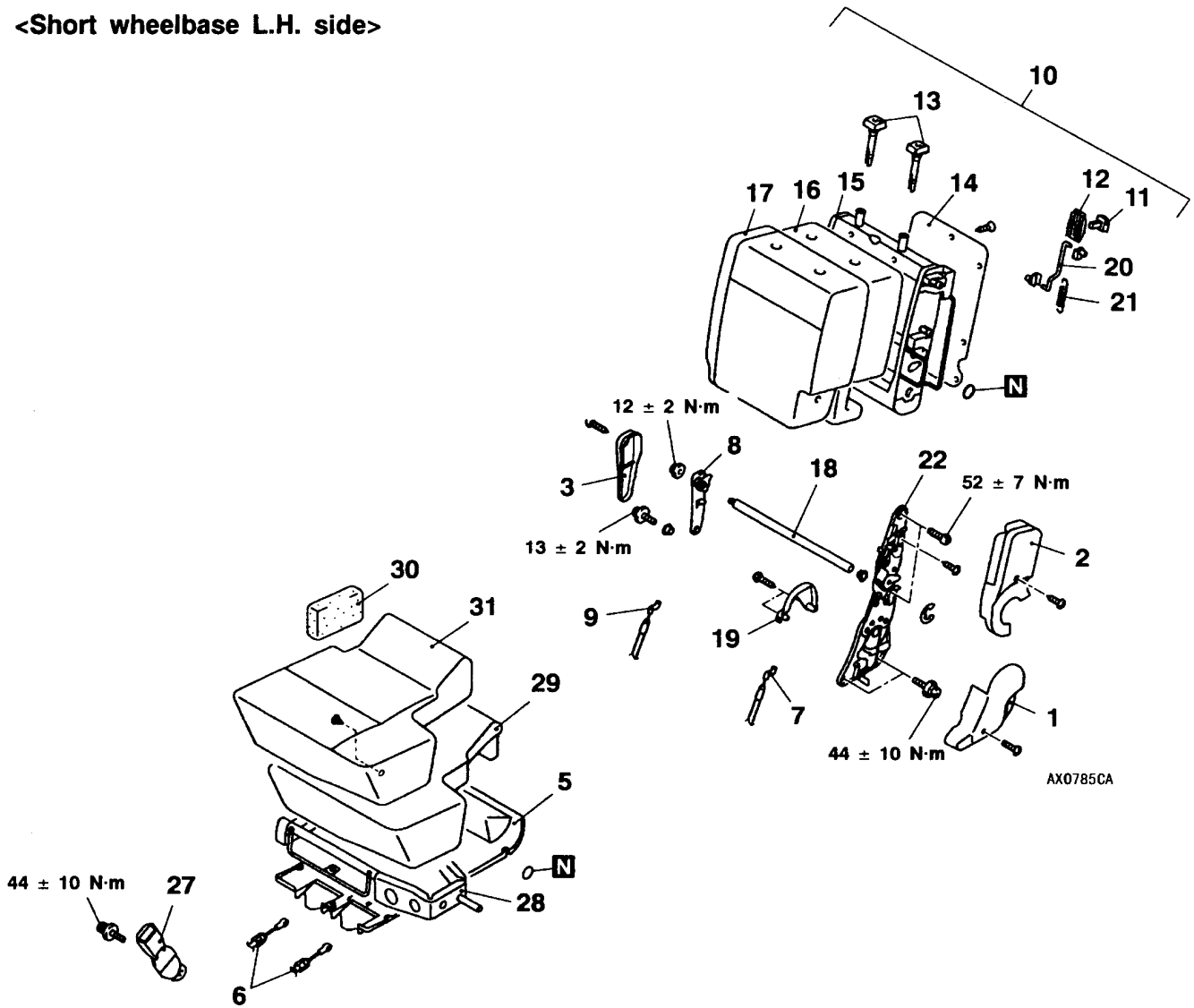

AX0785CA

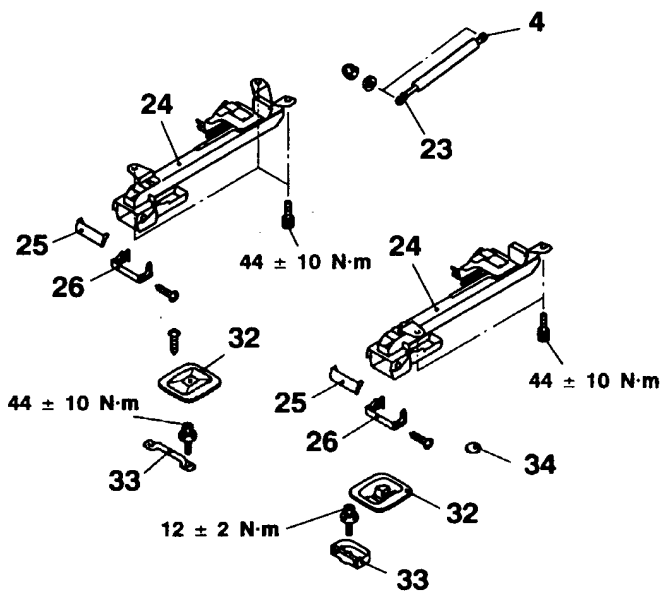

AX0786CA

Disassembly steps

1. Lower reclining adjuster cover
2. Center reclining adjuster cover
3. Free hinge cover
4. Gas damper connection
5. Rear seat cushion under cover
6. Catch cable A, B connection
7. Catch cable A
8. Hinge bracket
9. Catch cable B
10. Rear seat back assembly
11. Folding lever knob
12. Folding knob garnish
13. Headrest restraint guide
14. Rear seat back board
15. Rear seat back frame
16. Rear seat back pad
17. Rear seat back cover
18. Shaft
19. Reclining adjuster back cover
20. Rod
21. Spring
22. Reclining adjuster
23. Gas damper
24. Rear seat catch assembly
25. Upper foot cover
26. Lower foot cover
27. Inner seat belt
28. Rear seat cushion frame
29. Rear seat cushion pad
30. Support pad
31. Rear seat cushion cover
32. Striker cover
33. Striker
34. Plug

◀A▶

Disassembly steps

1. Lower reclining adjuster cover
2. Inner seat belt
3. Center reclining adjuster cover
4. Gas damper connection
5. Rear seat cushion under cover
6. Catch cable A connection
7. Catch cable A
8. Rear seat back assembly
9. Folding lever knob
10. Folding knob garnish
11. Rear seat back board
12. Headrest guide
13. Sash anchor garnish
14. Rear seat back frame
15. Rear seat back pad
16. Rear seat back cover
17. Seat belt protector
18. Center seat belt connection
19. Shaft
20. Reclining adjuster back cover
21. Rod
22. Spring
23. Reclining adjuster
24. Gas damper
25. Rear seat catch assembly
26. Upper foot cover
27. Lower foot cover
28. Inner seat belt
29. Center seat belt
30. Rear seat cushion frame
31. Rear seat cushion pad
32. Rear seat cushion cover
33. Striker cover
34. Striker
35. Plug

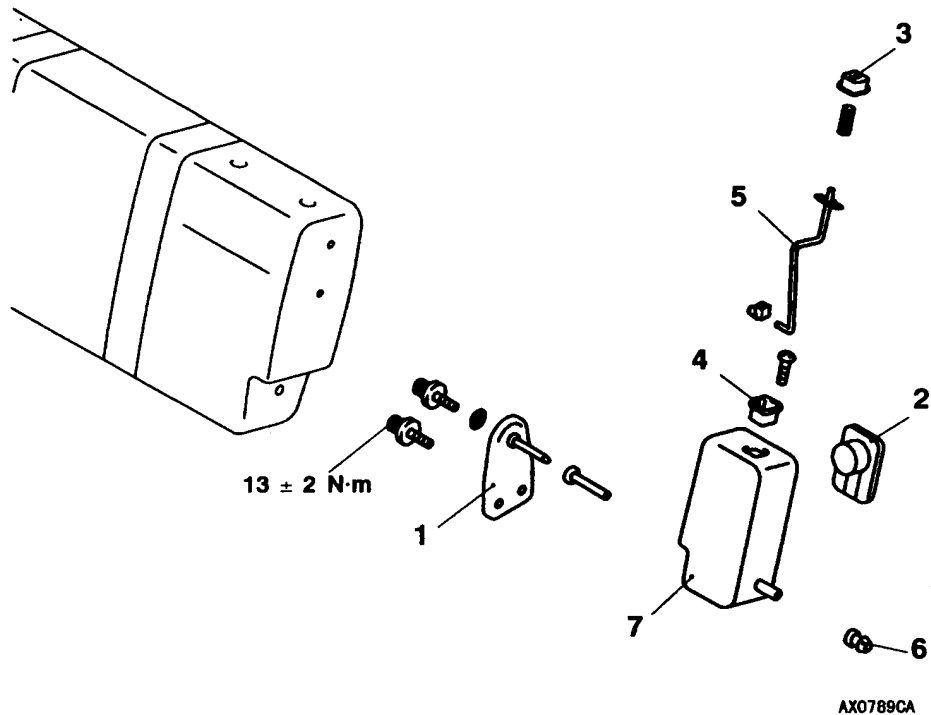
**<Short wheelbase-Rear seat side back assembly>****Disassembly steps**

1. Hinge bracket
2. Cup holder
3. Knob
4. Knob guide
5. Rod
6. Bushing
7. Rear seat side back

<Long wheelbase L.H. side>

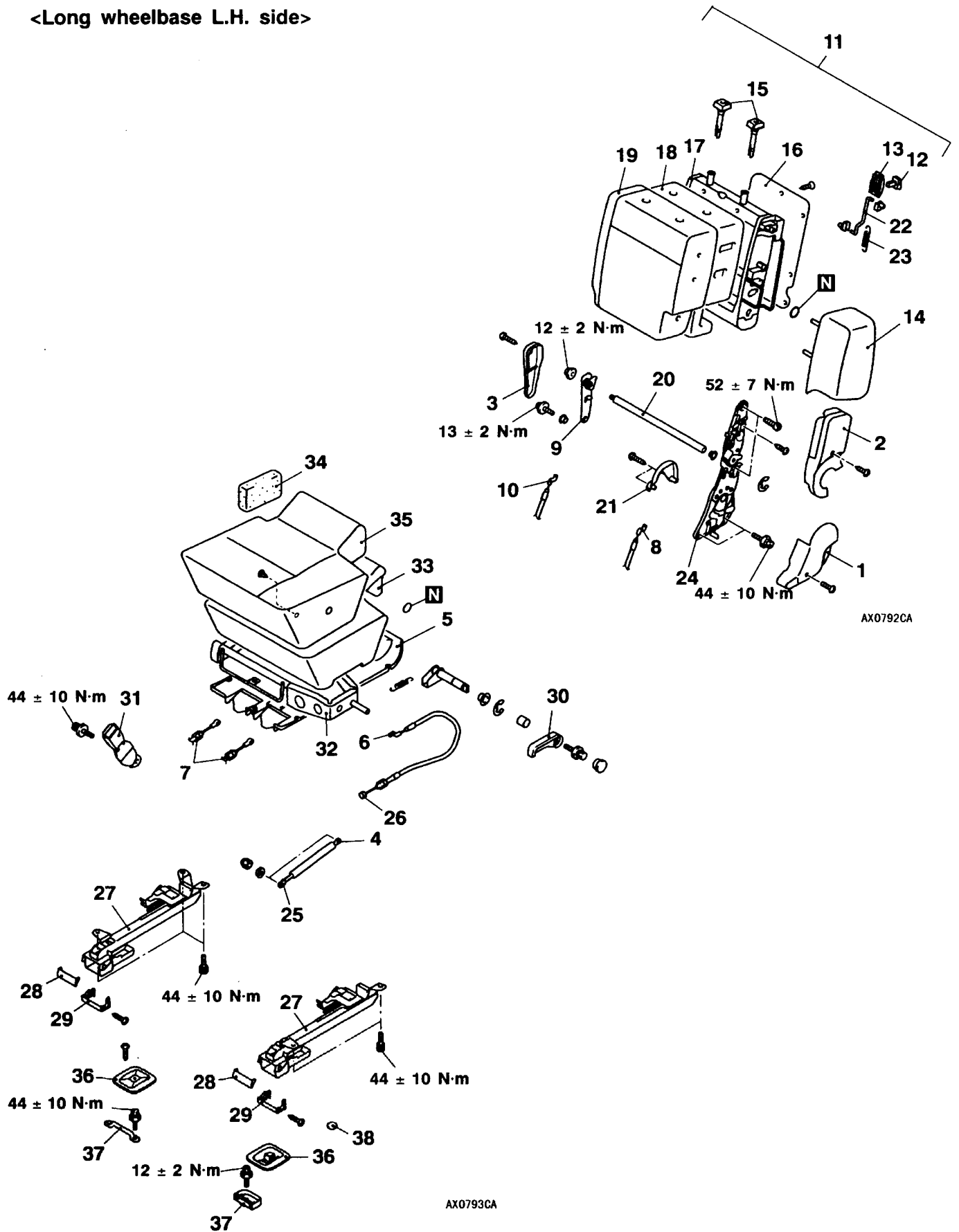

Disassembly steps

1. Lower reclining adjuster cover
2. Center reclining adjuster cover
3. Free hinge cover
4. Gas damper connection
5. Rear seat cushion under cover
6. Reclining cable connection
7. Catch cable A, B connection
8. Catch cable A
9. Hinge bracket
10. Catch cable B
11. Second seat back assembly
12. Folding lever knob
13. Folding knob garnish
14. Second seat side back assembly
15. Headrest restraint guide
16. Second seat back board
17. Second seat back frame
18. Second seat back pad
19. Second seat back cover
20. Shaft
21. Reclining adjuster back cover
22. Rod
23. Spring
24. Reclining adjuster
25. Gas damper
26. Reclining cable
27. Second seat catch assembly
28. Upper foot cover
29. Lower foot cover
30. Reclining knob
31. Inner seat belt
32. Second seat cushion frame
33. Second seat cushion pad
34. Support pad
35. Second seat cushion cover
36. Striker cover
37. Striker
38. Plug



<Long wheelbase R.H. side>

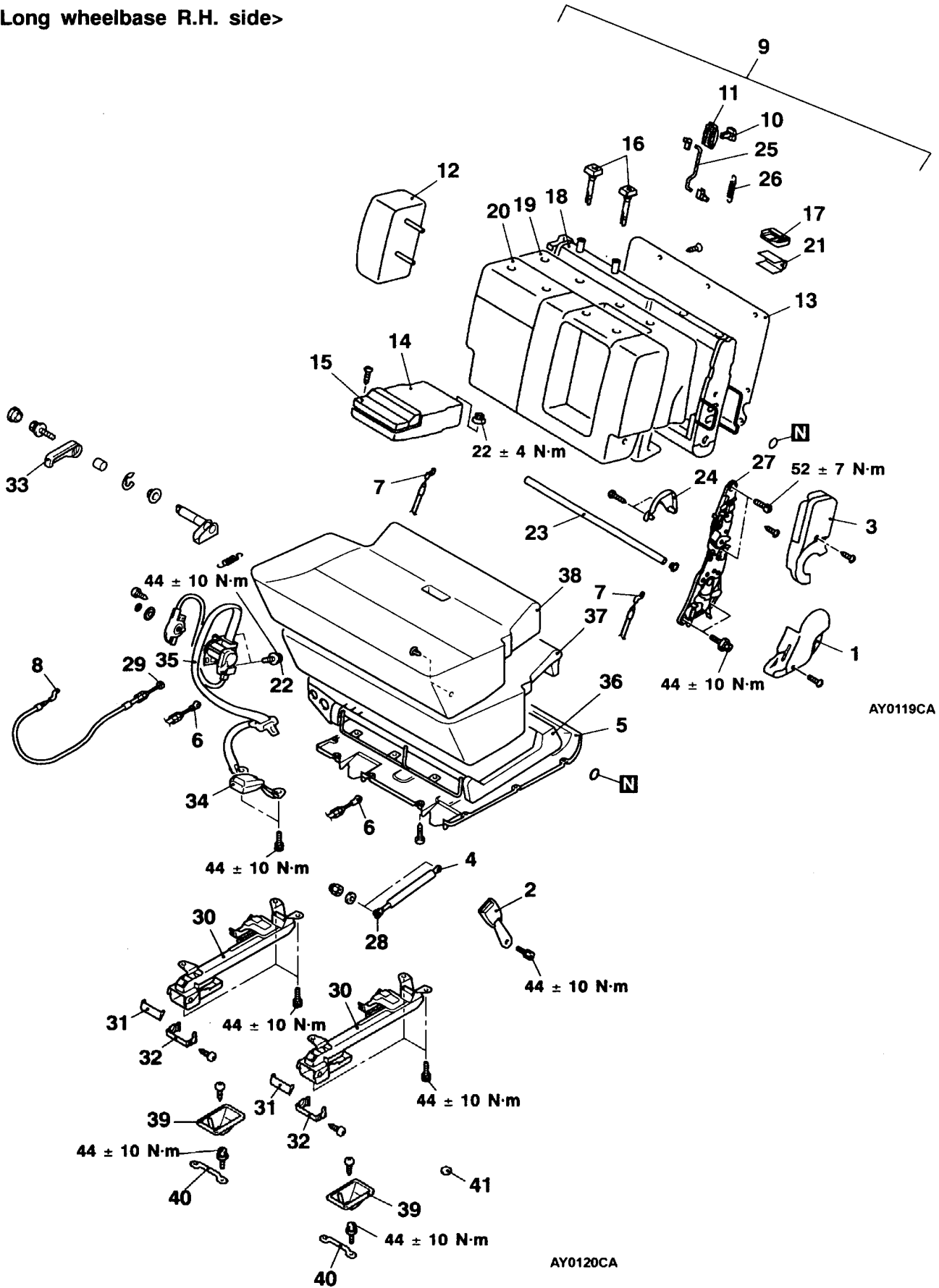

Disassembly steps

- | | |
|--|---|
| <ol style="list-style-type: none"> 1. Lower reclining adjuster cover 2. Inner seat belt 3. Center reclining adjuster cover 4. Gas damper connection 5. Rear seat cushion under cover 6. Catch cable A connection 7. Catch cable A 8. Reclining cable connection 9. Second seat back assembly 10. Folding lever knob 11. Folding knob garnish 12. Second seat side back assembly 13. Second seat back board 14. Armrest 15. Cup holder 16. Headrest guide 17. Sash anchor garnish 18. Second seat back frame 19. Second seat back pad 20. Second seat back cover 21. Seat belt protector | <ol style="list-style-type: none"> 22. Center seat belt connection 23. Shaft 24. Reclining adjuster back cover 25. Rod 26. Spring 27. Reclining adjuster 28. Gas damper 29. Reclining cable 30. Second seat catch assembly 31. Upper foot cover 32. Lower foot cover 33. Reclining knob 34. Inner seat belt 35. Center seat belt 36. Second seat cushion frame 37. Second seat cushion pad 38. Second seat cushion cover 39. Striker cover 40. Striker 41. Plug |
|--|---|

◀A▶

CLAW POSITION

<Lower reclining adjuster cover>

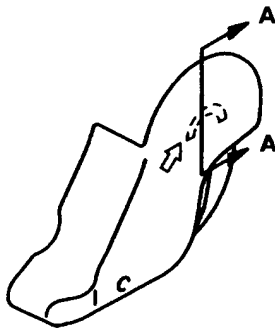

AX0800CA

Section A - A

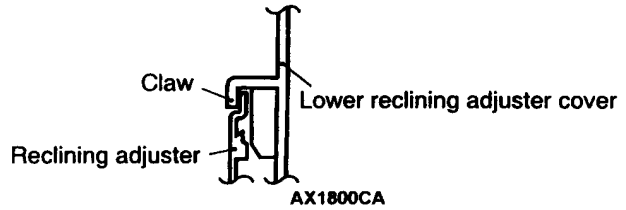

<Folding knob garnish>

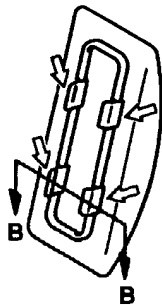

AX0830CA

Section B - B

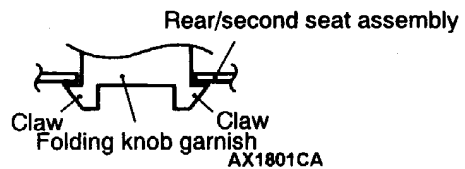

NOTE

◀▶ : Claw position

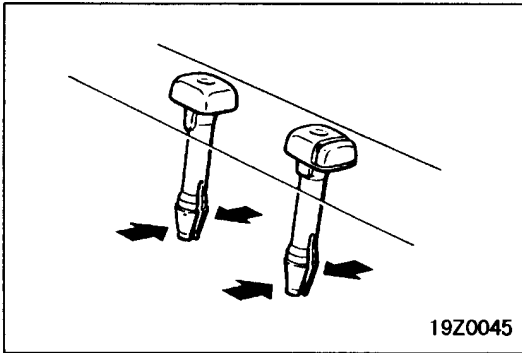

REMOVAL SERVICE POINT

◀▶ HEADRESTRAINT GUIDE REMOVAL

THIRD SEAT

DISASSEMBLY AND REASSEMBLY

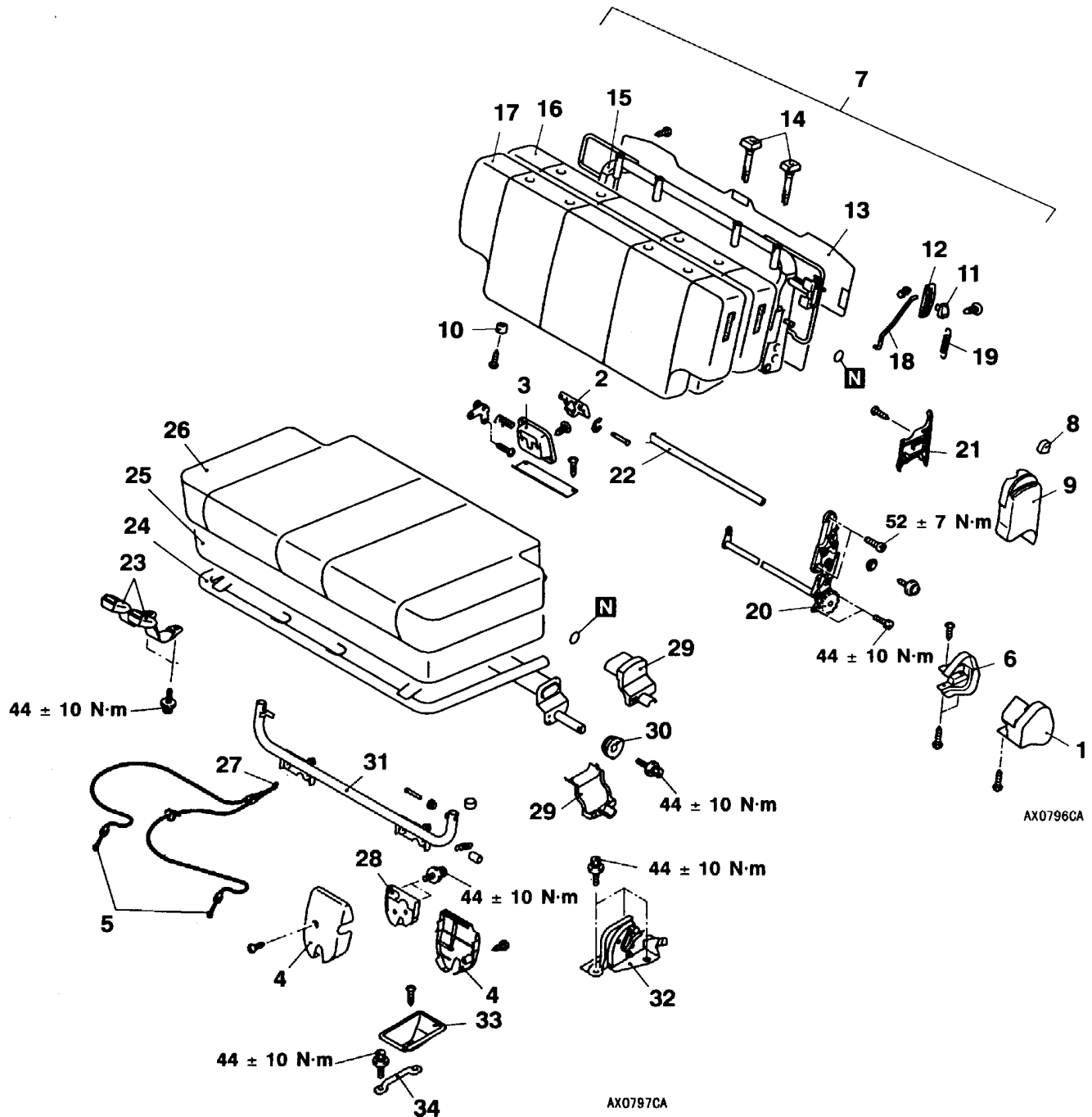

Disassembly steps

1. Outer reclining adjuster cover
2. Catch release knob
3. Catch release knob garnish
4. Latch cover
5. Catch cable connection
6. Inner reclining adjuster cover
7. Third seat back assembly
8. Reclining knob
9. Reclining adjuster cover
10. Damper
11. Folding lever knob
12. Folding knob garnish
13. Third seat back board
14. Headrest guide
15. Third seat back frame
16. Third seat back pad
17. Third seat back cover
18. Rod
19. Spring
20. Reclining adjuster
21. Inner reclining adjuster cover
22. Shaft
23. Inner seat belt
24. Third seat cushion frame
25. Third seat cushion pad
26. Third seat cushion cover
27. Catch cable
28. Third seat latch
29. Arm cover
30. Cam
31. Third seat leg frame assembly
32. Catch assembly
33. Striker cover
34. Striker



CLAW POSITION

<Outer reclining adjuster cover>

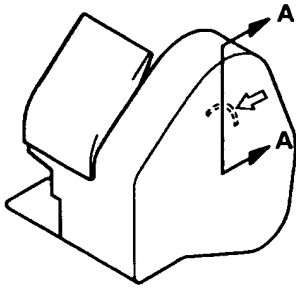

AX0805CA

Section A - A

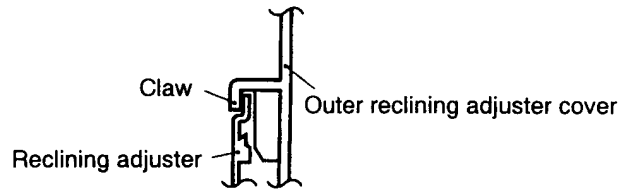

AX1264CA

<Reclining adjuster cover>

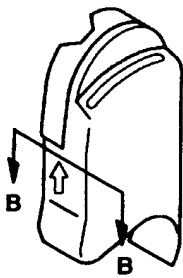

AX0806CA

Section B - B

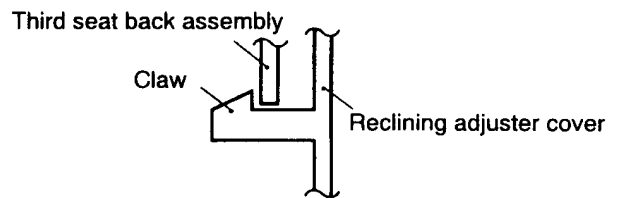

AX0834CA

<Folding knob garnish>

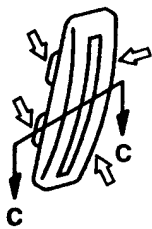

AX0829CA

Section C - C

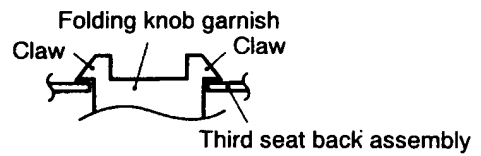

AX0835CA

<Arm cover>

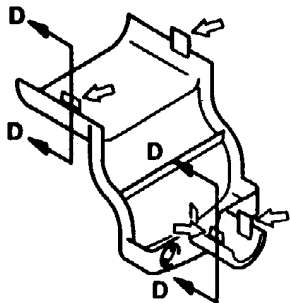

AX0807CA

Section D - D

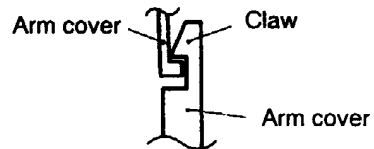

AX0836CA

NOTE
 ⇔ : Claw position

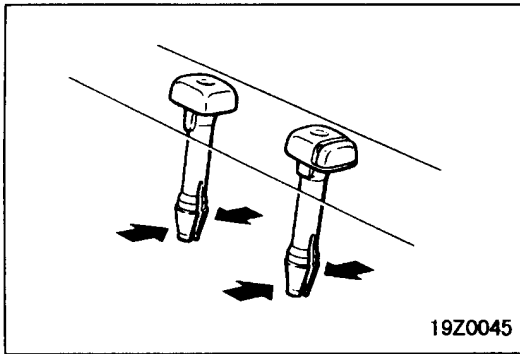
**DISASSEMBLY SERVICE POINT**◀▶ **HEADRESTRAINT GUIDE REMOVAL**

FRONT SEAT BELT REMOVAL AND INSTALLATION

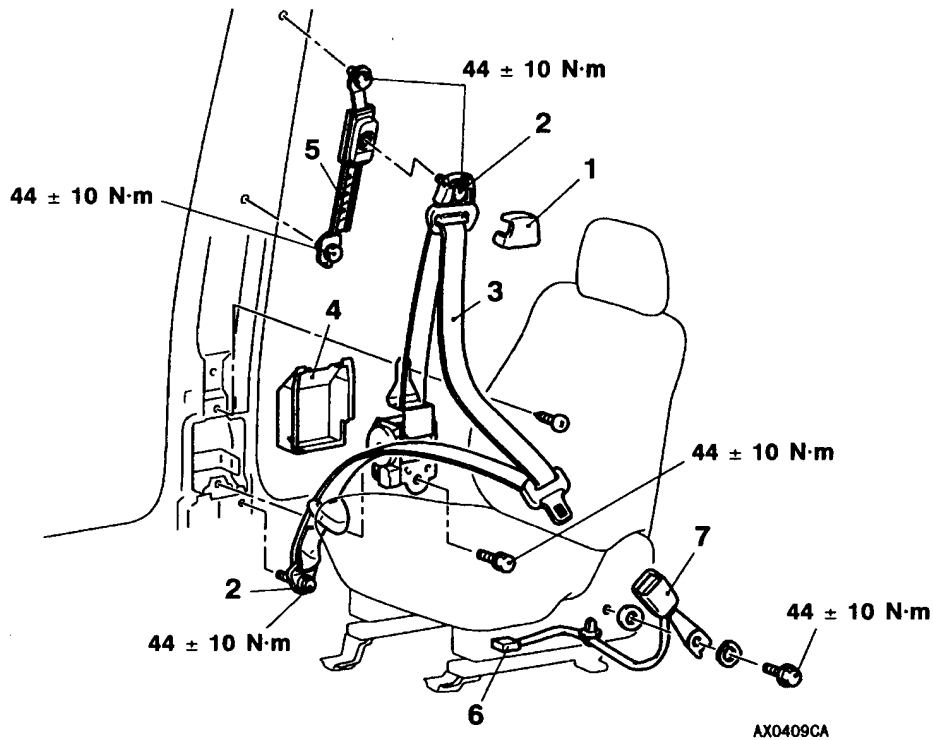
**Outer seat belt removal steps**

1. Sash guide cover
2. Outer seat belt connection
 - Lower quarter trim <Short wheelbase> (Refer to P.52A-13.)
 - Center pillar trim <Long wheelbase> (Refer to P.52A-15.)
3. Outer seat belt
4. Front noise protector
5. Shoulder anchor adjuster

Inner seat belt removal steps

- Front seat assembly (Refer to P.52A-18.)
- 6. Seat belt switch harness connector
- 7. Inner seat belt

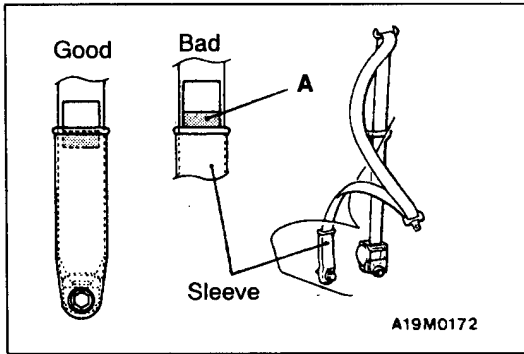

INSPECTION

OUTER SEAT BELT CHECK

Check that the A section (red) of the label attached to the outer seat belt is not exposed from the outer seat belt sleeve. If it is exposed, release the outer seat belt.

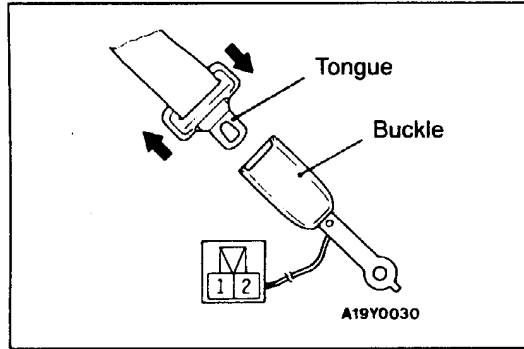

SEAT BELT BUCKLE CONTINUITY CHECK

Items	Terminal No.	
	1	2
Fastened seat belt		
Unfastened seat belt	○	○

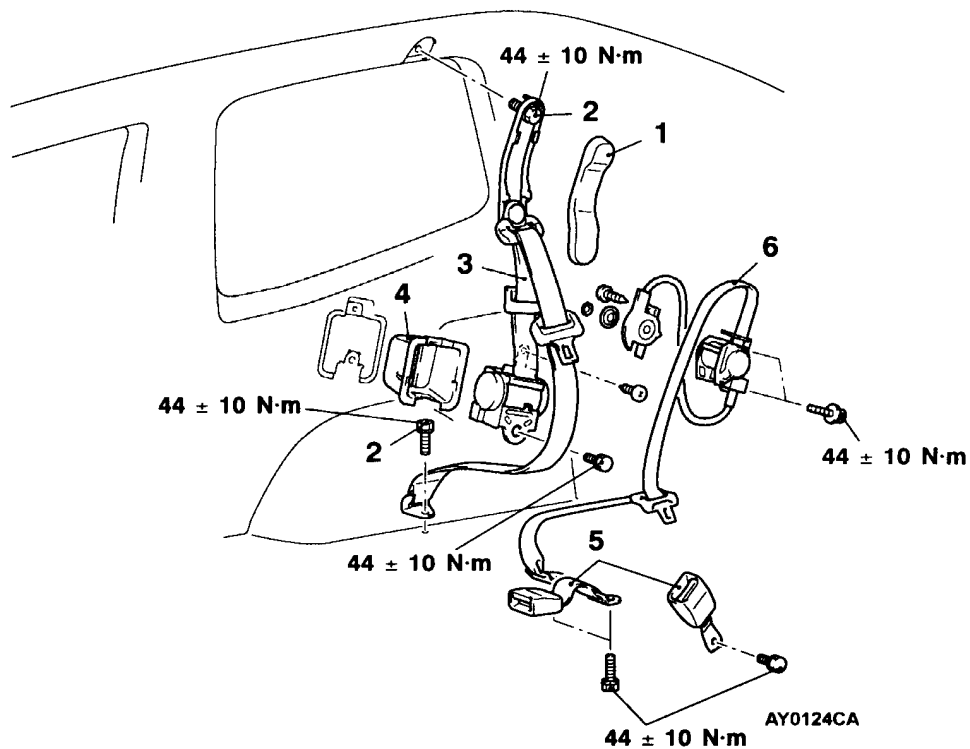
REAR SEAT BELT<SHORT WHEELBASE>**REMOVAL AND INSTALLATION****Outer seat belt removal steps**

- Rear seat assembly
(Refer to P.52A-25.)
- Upper quarter trim
(Refer to P.52A-13.)
- 1. Sash guide cover
- 2. Outer seat belt connection
- 3. Outer seat belt
- 4. ELR cover

Inner seat belt and center seat belt removal steps

- Rear seat assembly
(Refer to P.52A-25.)
- 5. Inner seat belt
(Refer to P.52A-27,29.)
- 6. Center seat belt
(Refer to P.52A-29.)

SUPPLEMENTAL RESTRAINT SYSTEM (SRS)

CONTENTS

GENERAL INFORMATION	2	FRONT IMPACT SENSORS	28
SRS SERVICE PRECAUTIONS	3	SRS AIR BAG CONTROL UNIT (SRS-ECU)	30
SPECIAL TOOLS	5	AIR BAG MODULES AND CLOCK SPRING	32
TEST EQUIPMENT	6	SIDE IMPACT SENSOR	41
TROUBLESHOOTING	7	AIR BAG MODULE DISPOSAL PROCEDURES	43
SRS MAINTENANCE	19	Undeployed Air Bag Module Disposal	43
POST-COLLISION DIAGNOSIS	23	Deployed Air Bag Module Disposal Procedures	52
INDIVIDUAL COMPONENT SERVICE	26		
WARNING/CAUTION LABELS	27		

CAUTION

- Carefully read and observe the information in the SERVICE PRECAUTIONS (P.52B-3.) prior to any service.
- For information concerning troubleshooting or maintenance, always observe the procedures in the Troubleshooting (P.52B-7.) section.
- If any SRS components are removed or replaced in connection with any service procedures, be sure to follow the procedures in the INDIVIDUAL COMPONENT SERVICE section (P.52B-26.) for the components involved.
- If you have any questions about the SRS, please contact your local distributor.

GENERAL INFORMATION

To improve safety, the SRS are available as optional parts. These systems enhance collision safety by restraining the front passengers in case of an accident.

The SRS consists of four air bag modules, SRS air bag control unit (SRS-ECU), front impact sensors, side impact sensors, SRS warning lamp and clock spring. The air bags are located in the centre of the steering wheel, above the glove box, and built into the front seat back assemblies. Each air bag has a folded air bag and an inflator unit. The SRS-ECU under the floor console monitors the system and has a safing G sensor and an analog G sensor. The front impact sensors are installed on the headlamp support panel. The side impact sensor, which is located inside the quarter panels <short wheelbase> or center pillar <long

wheelbase> inner, monitors any shocks coming from the side of the vehicle. The warning lamp on the instrument panel indicates the operational status of the SRS. The clock spring is installed in the steering column.

The SRS side air bag deploys if an impact received at the side of the vehicle is stronger than a certain set value, in order to protect the upper bodies of front seat passengers in the event of a collision. Only authorized service personnel should do work on or around the SRS components. Those service personnel should read this manual carefully before starting any such work. Extreme care must be used when servicing the SRS to avoid injury to the service personnel (by inadvertent deployment of the air bags) or the driver (by rendering the SRS inoperative).

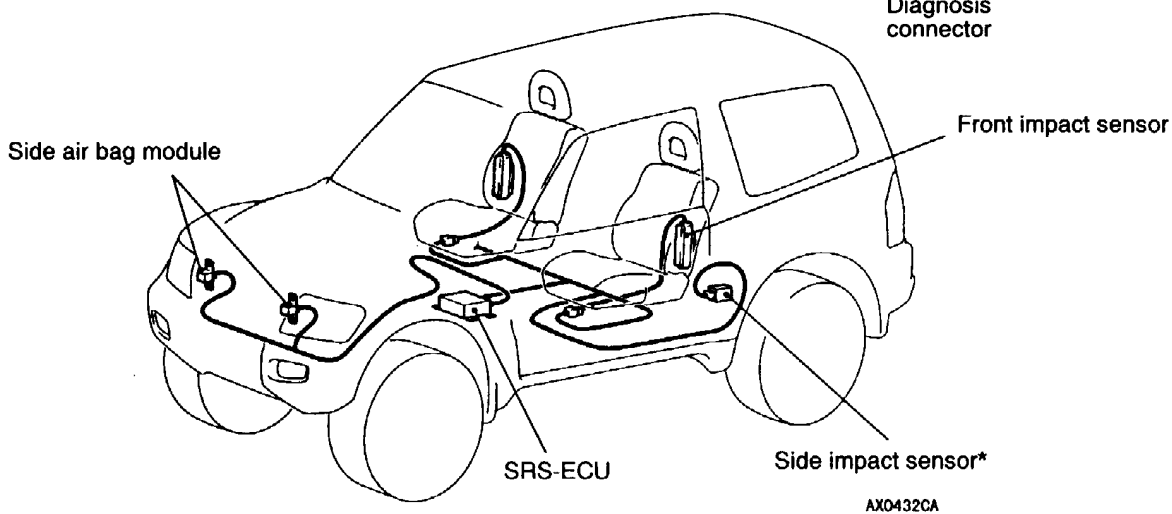
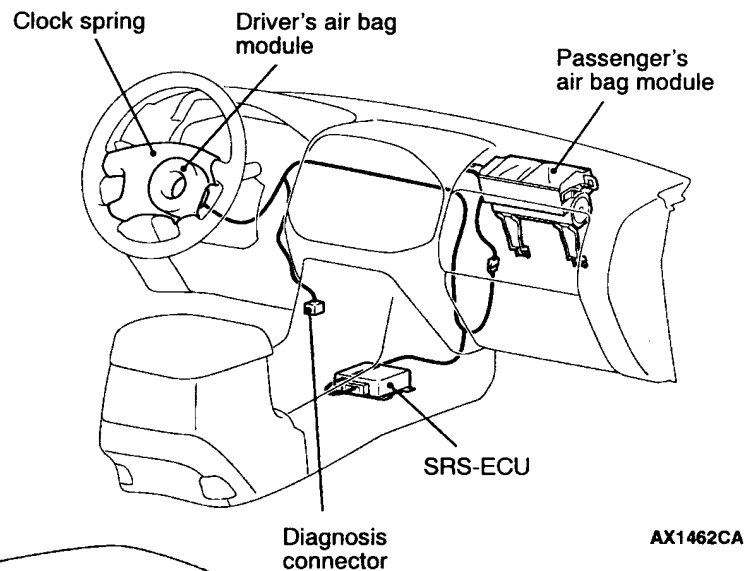
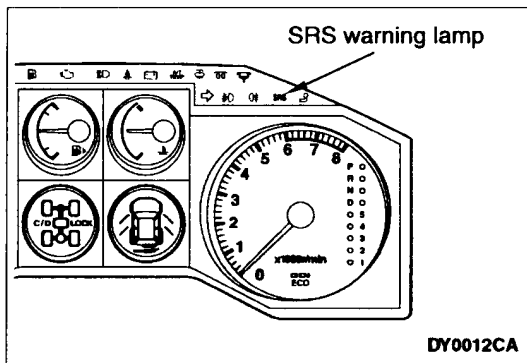

NOTE

*: Indicates the parts equipped on the right and left sides.

SRS SERVICE PRECAUTIONS

1. In order to avoid injury to yourself or others from accidental deployment of the air bag during servicing, read and carefully follow all the precautions and procedures described in this manual.
2. Do not use any electrical test equipment on or near SRS components, except those specified on P.52B-6.
3. **Never Attempt to Repair the Following Components:**
 - SRS air bag control unit (SRS-ECU)
 - Front impact sensor
 - Clock spring
 - Driver's and front passenger's air bag modules
 - Side air bag module
 - Side impact sensor

If any of these components are diagnosed as faulty, they should only be replaced, in accordance with the **INDIVIDUAL COMPONENTS SERVICE** procedures in this manual, starting at page 52B-26.

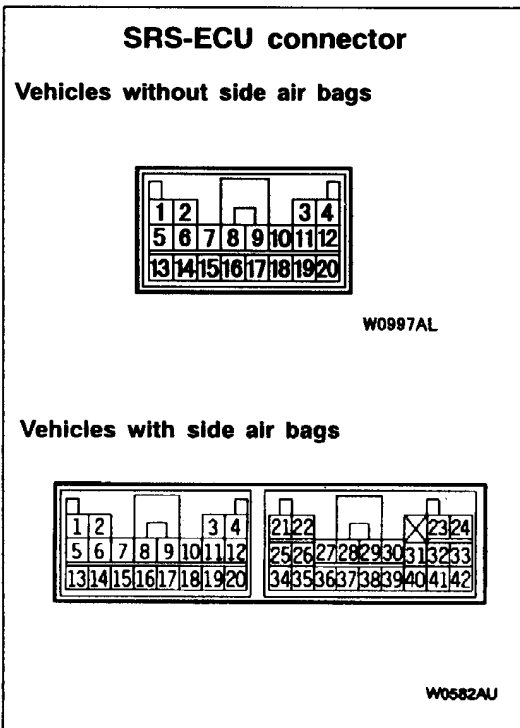

4. Do not attempt to repair the wiring harness connectors of the SRS. If a defective wiring harness is found, repair or replace it by referring to the table below.

SRS-ECU terminal No.	Destination of harness	Remedy
1, 2, 3, 4	Instrument panel wiring harness → Front wiring harness → Front impact sensor	Repair or replace each wiring harness.
7	Instrument panel wiring harness → Earth	Repair or replace the instrument panel wiring harness.
8	Instrument panel wiring harness → SRS warning lamp	
9, 10	Instrument panel wiring harness → Passenger's air bag module	
11, 12	Instrument panel wiring harness → Clock spring to driver's air bag module	Replace the clock spring or repair or replace the instrument panel wiring harness.
13	Instrument panel wiring harness → Junction block (fuse No.8)	Repair or replace the instrument panel wiring harness.
16	Instrument panel wiring harness → Junction block (fuse No.6)	
20	Instrument panel wiring harness → Diagnosis connector	
21, 22	Side air bag wiring harness → Left side air bag module	Repair or replace side air bag wiring harness.
23, 24	Side air bag wiring harness → Side air bag module (R.H.)	
34, 35, 36	Side air bag wiring harness → Floor wiring harness → Side impact sensor (L.H.)	Repair or replace each wiring harness.
40, 41, 42	Side air bag wiring harness → Floor wiring harness → Side impact sensor (R.H.)	

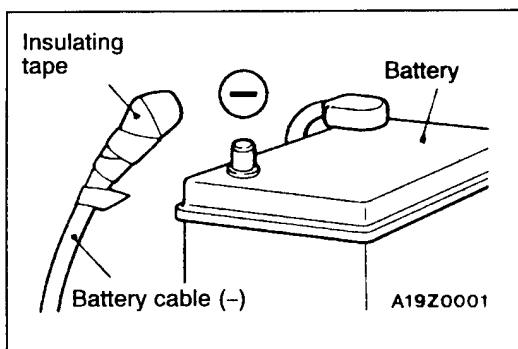

5. After disconnecting the battery cable, wait 60 seconds or more before proceeding with the following work. In addition, insulate the negative battery terminal with a tape. The condenser inside the SRS-ECU is designed to retain enough voltage to deploy the air bag for a short time even after the battery has been disconnected, so serious injury may result from unintended air bag deployment if work is done on the SRS system immediately after the battery cables are disconnected.

6. SRS components should not be subjected to heat over 93°C, so remove the SRS-ECU, front impact sensor, driver's air bag module, clock spring, passenger's air bag module, front seat assembly(side air bag module) and side impact sensor before drying or baking the vehicle after painting.
7. Whenever you finish servicing the SRS, always erase the diagnosis code and check warning lamp operation to make sure that the system functions properly. (Refer to P.52B-7)

8. If checks are carried out by using the SRS-ECU harness connector, observe the following procedures:

Insert the special tool (probe in the harness set) into connector from harness side (rear side), and connect the tester to this probe. If any tool than special tool is used, damage to the harness and other components will result. Never insert the probe directly to the terminals from the front of the connector. The terminals are plated to increase their conductivity, so that if they are touched directly by the probe, the plating may break, which will cause drops in reliability.

Vehicles without side air bags

SRS-ECU harness connector

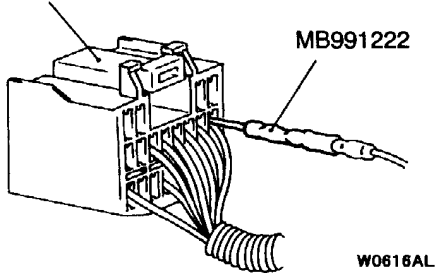

SRS-ECU harness connector (rear view)

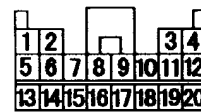

W0999AL

Vehicles with side air bags

SRS-ECU harness connector

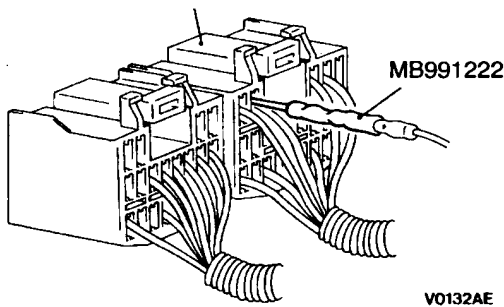

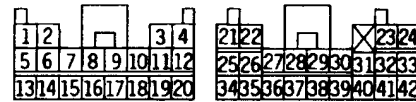

SRS-ECU harness connector (rear view)

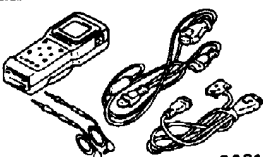
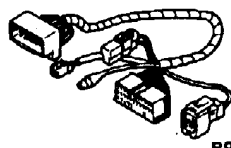

W0584AU

SPECIAL TOOLS

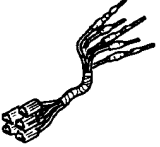
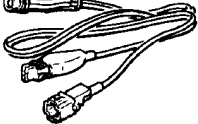
Tools	No.	Name	Application
 <p>B991502</p>	MB991502	MUT-II sub assembly	<ul style="list-style-type: none"> • Reading and erasing diagnosis code • Reading trouble period • Reading erase times
 <p>B991613</p>	MB991606 or MB991613	SRS check harness	Checking SRS electrical circuitry

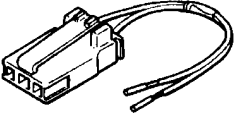
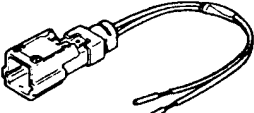
Tools	No.	Name	Application
<p>A</p>  <p>B</p>  <p>C</p>  <p>D</p>  <p>C991223</p>	<p>MB991223</p> <p>A: MB991219</p> <p>B: MB991220</p> <p>C: MB991221</p> <p>D: MB991222</p>	<p>Harness set</p> <p>A: Check harness</p> <p>B: LED harness</p> <p>C: LED harness adapter</p> <p>D: Probe</p>	<p>Checking continuity and measuring voltage at SRS-ECU harness connector</p>
 <p>R372530</p>	<p>MR372530</p>	<p>SRS air bag adapter harness</p>	<p>Deploying driver's air bag module inside vehicle</p>
 <p>8686560</p>	<p>MB686560</p>	<p>SRS air bag adapter harness</p>	<p>Deploying front passenger's air bag module and side air bag modules inside or outside vehicle</p>

TEST EQUIPMENT

Tool	Name	Application
 <p>13R0748</p>	<p>Digital multi-meter</p>	<p>Checking SRS electrical circuitry (Use multi-meter for which the maximum test current is 2 mA or less at minimum range of resistance measurement)</p>

TROUBLESHOOTING

STANDARD FLOW OF DIAGNOSTIC TROUBLESHOOTING

Refer to GROUP 00 – How to Use Troubleshooting/Inspection Service Points.

DIAGNOSIS FUNCTION

DIAGNOSIS CODES CHECK

Connect the MUT-II to the diagnosis connector (16-pin) under the instrument cover, then check diagnosis codes.

(Refer to GROUP 00 – How to Use Troubleshooting/Inspection Service Points.)

ERASING DIAGNOSIS CODES

WHEN USING THE MUT-II

Connect the MUT-II to the diagnosis connector and erase the diagnosis code.

Caution

Turn off the ignition switch before connecting or disconnecting the MUT-II.

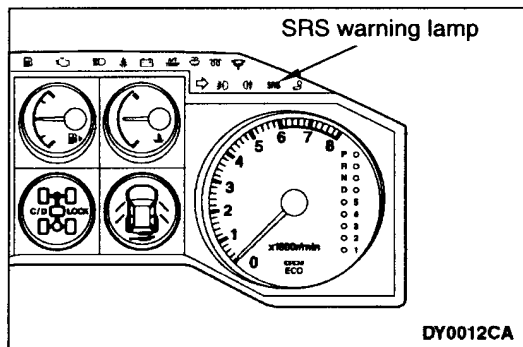

SRS WARNING LAMP CHECK

1. Check that the SRS warning lamp comes on when the ignition switch is turned ON.
2. Check that the SRS warning lamp illuminates for about 7 seconds and then goes out.
3. If this is not the cause, check the diagnosis codes.

INSPECTION CHART FOR DIAGNOSIS CODES

Code No.	Diagnosis item	Reference page
11, 12, 13	Front impact sensor system	52B-8
14	Front impact analog G-sensor system inside SRS-ECU	52B-9
15, 16	Front impact safing G-sensor system inside SRS-ECU	52B-9
17	Side impact safing G-sensor system inside SRS-ECU	52B-9
21*2, 22*2, 61, 62	Driver's air bag module (squib) system	52B-10
24*2, 25*2, 64, 65	Passenger's air bag module (squib) system	52B-12
31, 32	DC-DC converter system inside SRS-ECU	52B-9
34*1	Connector lock system	52B-13
35	SRS-ECU (deployed air bag) system	52B-13
41*1	Power circuit system (fuse No.6 circuit)	52B-13
42*1	Power circuit system (fuse No.8 circuit)	52B-13

Code No.	Diagnosis item	Reference page
43*1	SRS warning lamp drive circuit system	Lamp does not illuminate.
		Lamp does not go out off.
44*1	SRS warning lamp drive circuit system	52B-14
45	Internal circuit system of non-volatile memory (EEPROM) inside SRS-ECU	52B-9
51, 52	Driver's air bag module (squib) system	52B-9
54, 55	Passenger's air bag module (squib) system	52B-9
71*2, 72*2, 75, 76	Side air bag module (R.H.) (squib) system	52B-15
73, 74	Side air bag module (R.H.) (squib) system	52B-9
79, 93	Side impact sensor (L.H.) communication system	52B-16
81*2, 82*2, 85, 86	Side air bag module (L.H.) (squib) system	52B-16
83, 84	Side air bag module (L.H.) (squib ignition drive circuit) system	52B-9
89, 96	Side impact sensor (R.H.) communication system	52B-17
91*1	Side impact sensor (L.H.) power supply circuit system	52B-17
92	Analog G-sensor system inside side impact sensor	52B-17
94*1	Side impact sensor (R.H.) power supply circuit	52B-18
95	Analog G-sensor system inside side impact sensor (R.H.)	52B-17

NOTE

- *1: If the trouble(s) are extinguished, the SRS warning lamp will go out with diagnosis code history automatically erased.
- *2: If the vehicle condition return to normal, the diagnosis code will be automatically erased, and the SRS warning lamp will return to normal.
- If the vehicle has a discharged battery, it will store the fault codes 41 or 42. When these diagnosis codes are displayed, check the battery.

INSPECTION PROCEDURE CLASSIFIED BY DIAGNOSIS CODE

Code No.11, 12 or 13 Front impact sensor system	Probable cause
These diagnosis codes are output if there is abnormal resistance between the input terminals of the front impact sensors inside the SRS-ECU. The trouble causes for each diagnosis code No. are as follow.	<ul style="list-style-type: none"> ● Malfunction of harness or connector ● Malfunction of front impact sensor ● Malfunction of SRS-ECU

Table 1

Code No.	Trouble Symptom
11	<ul style="list-style-type: none"> ● Short circuit in front impact sensor or harness ● Short circuit in front impact sensor harness leading to the vehicle body ground ● Short circuit in front impact sensor harness leading to the power supply
12	<ul style="list-style-type: none"> ● Open circuit in either left or right front impact sensor or harness ● Short circuit in front impact sensor harness leading to the power supply
13	<ul style="list-style-type: none"> ● Open circuit in both left and right front impact sensor or harness ● Short circuit in front impact sensor harness leading to the power supply

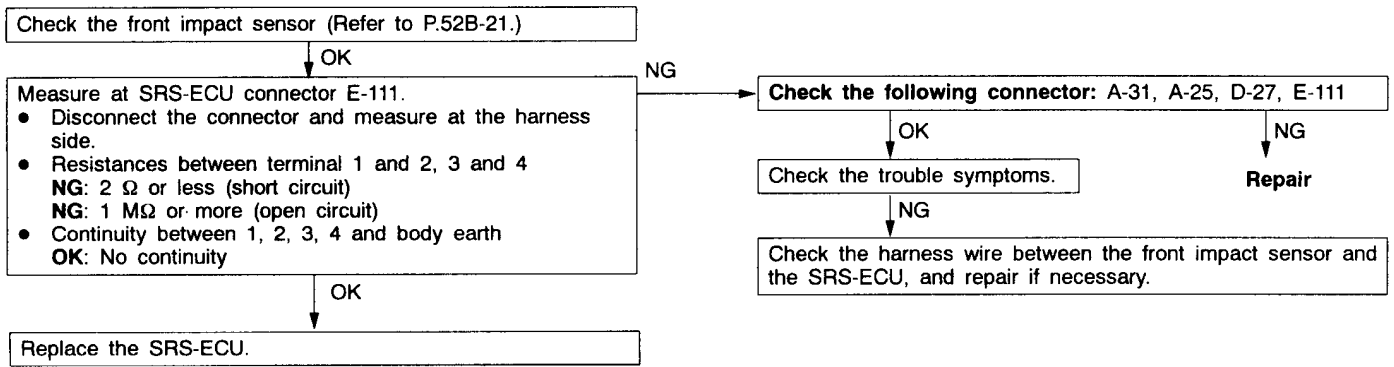

Code No.14, 15, 16, 17, 31, 32, 45, 51, 52, 54, 55, 73, 74, 83, 84 System inside SRS-ECU	Probable cause
These diagnosis trouble codes are output when a fault is detected in the SRS-ECU. The trouble causes for each diagnosis code No. are as follows.	Malfunction of SRS-ECU

Table 2

Code No.	Defective part	Trouble Symptom
14	Front impact analog G-sensor	<ul style="list-style-type: none"> When the analog G-sensor is not operating When the characteristics of the analog G-sensor are abnormal When the output from the analog G-sensor is abnormal
15	Front impact safing G-sensor	Short circuit in the safing G-sensor
16		Open circuit in the safing G-sensor
17	Side impact safing G-sensor	<ul style="list-style-type: none"> When the safing G-sensor is not operating When the characteristics of the safing G-sensor are abnormal When the output from the safing G-sensor is abnormal
31	DC-DC converter	Voltage at the DC-DC converter terminal is higher than the specified value for five seconds or more.
32		Voltage at the DC-DC converter terminal is lower than the specified value for five seconds or more(this is not detected if diagnosis code No.41 or 42 indicating battery voltage drop has been output.)
45	Non-volatile memory (EEPROM)	When the non-volatile memory (EEPROM) is abnormal
51	Driver's side air bag module (squib)	Short circuit in the squib ignition drive circuit
52		Open circuit in the squib ignition drive circuit
54	Passenger's air bag module (squib)	Short circuit in the squib ignition drive circuit
55		Open circuit in the squib ignition drive circuit
73	Side air bag module (R.H.) (squib)	Short circuit in the squib ignition drive circuit
74		Open circuit in the squib ignition drive circuit
83	Side air bag module (L.H.) (squib)	Short circuit in the squib ignition drive circuit
84		Open circuit in the squib ignition drive circuit

Replace the SRS-ECU.

Code No.21, 22, 61, 62 Driver's side air bag module (squib) system	Probable cause
<p>These diagnosis codes are output if there is an abnormal resistance between the input terminals of the driver's side air bag module (squib) inside the SRS-ECU. The trouble causes for each diagnosis code No. are as follow. However, as for code Nos.21 and 22, if the vehicle's condition return to normal, SRS warning lamp will go out. (Diagnosis code will remain stored)</p>	<ul style="list-style-type: none"> ● Malfunction of clock spring ● Partially open as clock spring is not in neutral position ● Malfunction of harness or connector ● Malfunction of driver's air bag module (squib) ● Malfunction of SRS-ECU

Table 3

Code No.	Trouble Symptom
21	<ul style="list-style-type: none"> ● Short circuit in driver's air bag module (squib) or harness short ● Short circuit in clock spring ● Poor connector contact*
22	<ul style="list-style-type: none"> ● Open circuit in driver's air bag module (squib) or open harness ● Open circuit in clock spring ● Disconnected driver's air bag module (squib) connector ● Partially open as clock spring is not in neutral position ● Poor connector contact
61	Short circuit in driver's air bag module (squib) harness leading to the power supply
62	Short circuit in driver's air bag module (squib) harness leading to the earth

NOTE

*: The shorting bars, which short positive (+) and negative (-) wires to prevent the air bags from accidental deployment during the disconnection of the connector, are set in the squib circuit connectors. In a defective connector, the short-bar may be still working even after the connection of the connector.

Check the clock spring (Refer to P.52B-37.)

NG → **Replace**

OK ↓

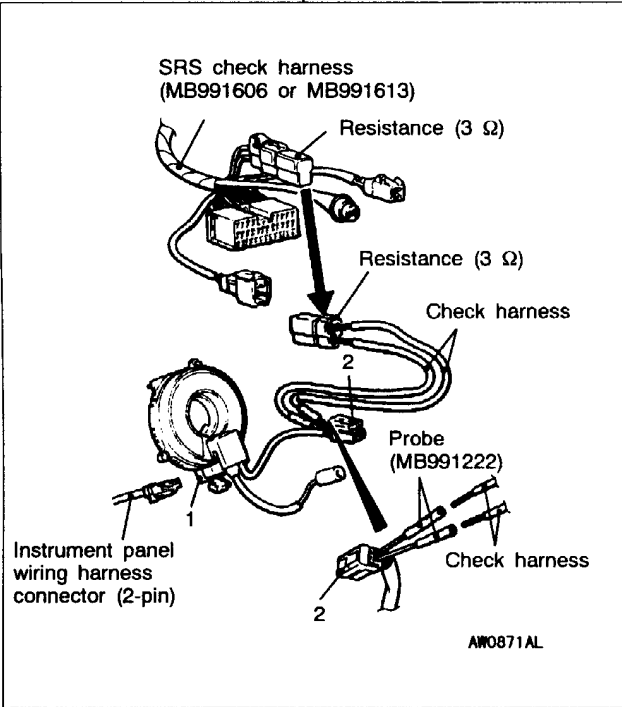

MUT-II Self-Diag Code

- Connect clock spring connector No.1 D-206 and the harness side connector(2-pin).
 - Insert the probes (MB991222) from the rear of the clock spring No.2connector and connect the check harness to the probe.
- Caution**
Never insert the probe directly to the terminals from the front of the connector.
- Disconnect the resistance connector from the SRS check harness (MB991606 or MB991613) and connect to the check harness.
 - Connect the negative (-) battery terminal.
 - Erase diagnosis code memory.
- Is code Nos.21, 22, 61 or 62 displayed?

YES ↓

Check the following connector: D-206, E-111

OK ↓

Check the trouble symptoms.

NG ↓

Check wiring harness between clock spring and SRS-ECU.

OK ↓

Replace the SRS-ECU.

NG ↓

Repair

NO ↓

Replace driver's air bag module (squib).

Code No.24, 25, 64, 65 Passenger's air bag module (squib) system	Probable cause
These diagnosis codes are output if there is an abnormal resistance between the input terminals of the passenger's air bag module (squib) inside the SRS-ECU. The trouble causes for each diagnosis code No. are as follow. However, as for code Nos.24, 25, if the vehicle's condition return to normal, SRS warning lamp will go out. (Diagnosis code will remain stored).	<ul style="list-style-type: none"> ● Malfunction of harness or connector ● Malfunction of passenger's air bag module (squib) ● Malfunction of SRS-ECU

Table 4

Code No.	Trouble Symptom
24	<ul style="list-style-type: none"> ● Short in passenger's air bag module (squib) or harness short ● Poor connector contact*
25	<ul style="list-style-type: none"> ● Open circuit in passenger's air bag module (squib) or open harness ● Poor connector contact
64	Short in passenger's air bag module (squib) harness leading to the power supply
65	Short in passenger's air bag module (squib) harness leading to the earth

NOTE

*: The shorting bars, which short positive (+) and negative (-) wires to prevent the air bags from accidental deployment during the disconnection of the connector, are set in the squib circuit connectors. In a defective connector, the short-bar may be still working even after the connection of the connector.

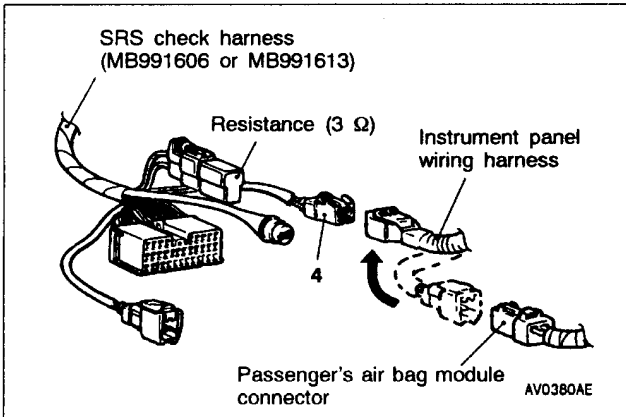

MUT-II Diagnosis Code

- Disconnect passenger's air bag module connector D-10, and connect the harness side connector to SRS check harness (MB991606 or MB991613) connector No.4.
- Connect the negative (-) battery terminal.
- Erase diagnosis code memory.

 Is code Nos.24, 25, 64 or 65 output?

```

                    graph TD
                        Start[YES] --> Step1[Check the following connectors: D-10, E-111]
                        Step1 -- OK --> Step2[Check the trouble symptoms.]
                        Step1 -- NG --> Repair1[Repair]
                        Step2 -- NG --> Step3[Check the harness wire between the passenger's air bag module (squib) and the SRS-ECU.]
                        Step2 -- OK --> Step4[Replace the SRS-ECU.]
                        Step3 -- OK --> Step4
                        Step3 -- NG --> Repair2[Repair]
                        Start -- NO --> Step5[Replace passenger's air bag module (squib).]
                    
```

Code No.34 Connector lock system	Probable cause
This diagnosis code is output when the SRS-ECU detects that the SRS-ECU connector is improperly connected. However, when vehicle condition returns to normal, this code will be automatically erased, and the SRS warning lamp will go out.	<ul style="list-style-type: none"> • Malfunction of connector • Malfunction of SRS-ECU

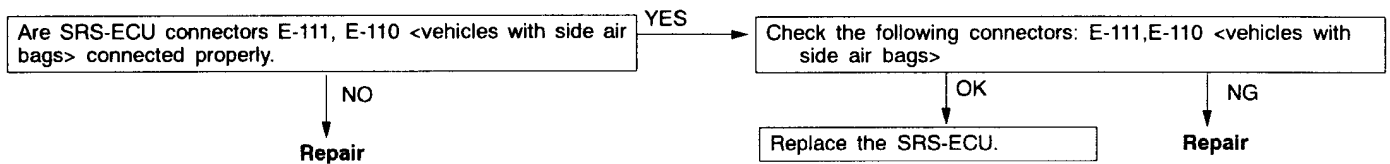

Code No.35 SRS-ECU (deployed air bag) system	Probable cause
This code is displayed after deployment of air bags. If displayed before deployment, the code indicates malfunction probably present in SRS-ECU.	Malfunction of SRS-ECU

Replace the SRS-ECU.

Code No.41 Power circuit system (fuse No.6 circuit) Code No.42 Power circuit system (fuse No.8 circuit)	Probable cause
Code No.41 is displayed if voltage between IG ₁ terminal (SRS-ECU, terminal 16) and earth is lower than specified for five successive seconds or more. Code No.42 is displayed if voltage between IG ₁ terminal (SRS-ECU, terminal 13) and earth is lower than specified for five successive seconds or more. However, when vehicle condition returns to normal, these codes will be automatically erased, and the SRS warning lamp will go out. If codes No.41 and 42 are displayed together, check the battery first as vehicle may have discharged battery.	<ul style="list-style-type: none"> • Malfunction of harness or connector • Malfunction of SRS-ECU

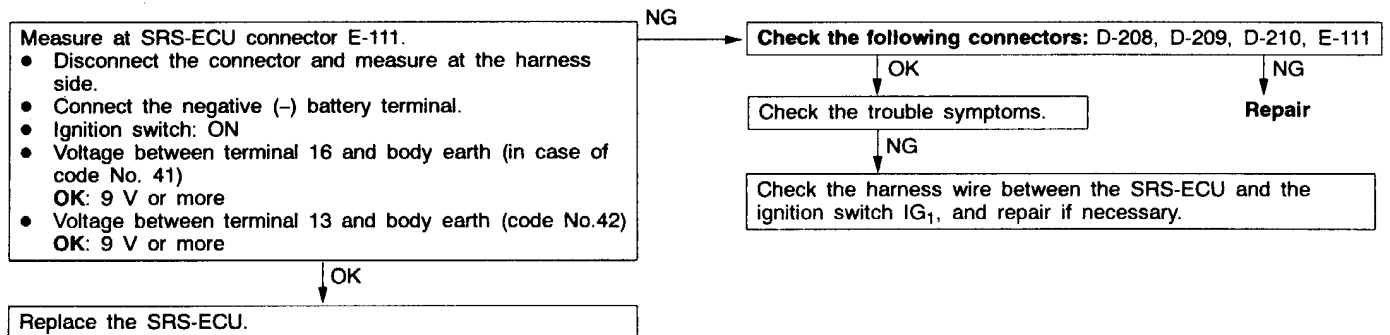

Code No.43 SRS warning lamp drive circuit system (Lamp does not come on.)	Probable cause
This diagnosis code is output when a open circuit is present for 5 successive seconds or more in SRS warning lamp drive circuit. However, the vehicle condition return to normal condition, this code, if displayed due to open circuit, will be automatically erased.	<ul style="list-style-type: none"> ● Malfunction of harness or connector ● Blown bulb ● Malfunction of SRS-ECU ● Malfunction of combination meter

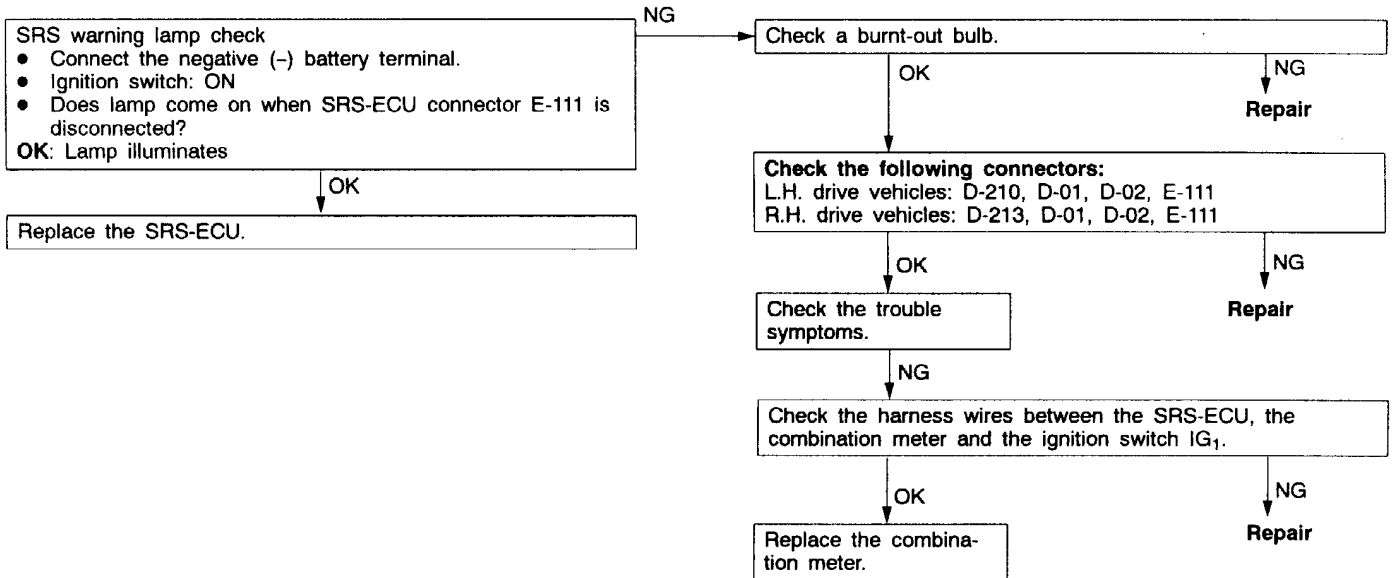

Code No.43 SRS warning lamp drive circuit system (Lamp does not go out.)	Probable cause
This diagnosis code is output when a short to earth occurs in the harness between the SRS warning lamp and the SRS-ECU. However, the vehicle condition returns to normal condition, this code will be automatically erased, and SRS warning lamp will go out.	<ul style="list-style-type: none"> ● Malfunction of harness or connector ● Malfunction of SRS-ECU ● Malfunction of combination meter

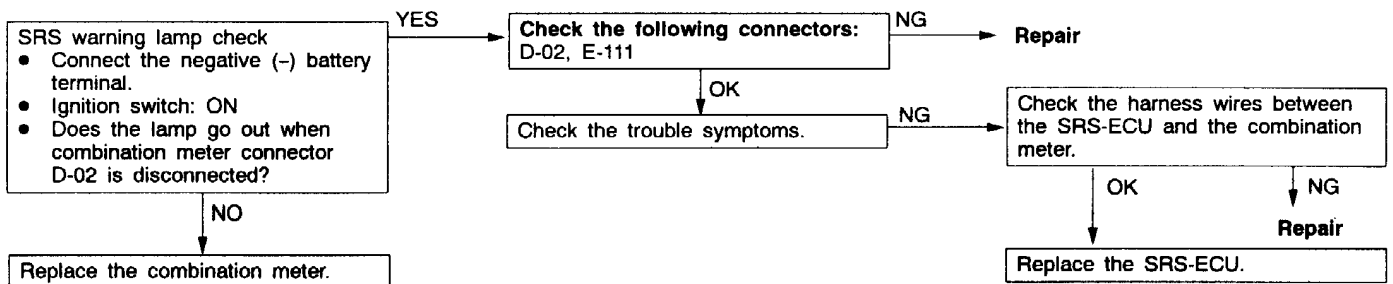

Code No.44 SRS warning lamp drive circuit system	Probable cause
This diagnosis code is output when a short occurs in the lamp drive circuit or a malfunction of the output transistor inside the SRS-ECU is detected while the SRS-ECU is monitoring the SRS warning lamp drive circuit. However, when vehicle condition returns to normal, these codes will be automatically erased, and the SRS warning lamp will go out.	<ul style="list-style-type: none"> ● Malfunction of harness or connector ● Malfunction of SRS-ECU

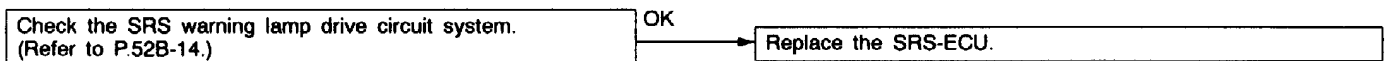

Code No. 71, 72, 75, 76 Side air bag module (R.H.) (squib) system	Probable cause
These diagnosis codes are output if there is an abnormal resistance between the input terminals of the side air bag module (R.H.) (squib) inside the SRS-ECU. The trouble causes for each diagnosis code No. are as follow. However, as for code No.71, 72, if the vehicle condition returns to normal, the SRS warning lamp will go out. (Diagnosis code will remain stored).	<ul style="list-style-type: none"> ● Malfunction of harness or connector ● Malfunction of side air bag module (R.H.) (squib) ● Malfunction of SRS-ECU

Table 5

Code No.	Trouble Symptom
71	Short in side air bag module (R.H.) (squib) or harness short
72	<ul style="list-style-type: none"> ● Open in side air bag module (R.H.) (squib) or open harness ● Poor connector contact
75	Short in side air bag module (R.H.) (squib) harness leading to the power supply
76	Short in side air bag module (R.H.) (squib) harness leading to the earth

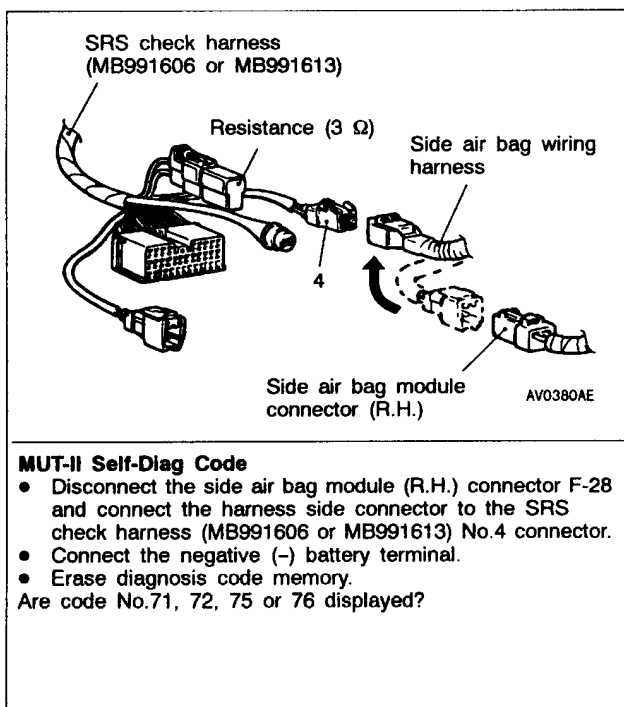

```

    graph TD
        Start[YES] --> Step1[Check the following connectors: F-28, E-110]
        Step1 -- OK --> Step2[Check the trouble symptoms.]
        Step1 -- NG --> Repair1[Repair]
        Step2 -- NG --> Step3[Check wiring harness between the side air bag module (R.H.) (squib) and SRS-ECU.]
        Step2 -- OK --> Step4[Replace the SRS-ECU.]
        Step3 -- OK --> Step4
        Step3 -- NG --> Repair2[Repair]
        Start -- NO --> Step5[Replace the driver's front seat back assembly.]
    
```

Code No.79, 93 Side impact sensor communication system (L.H.)	Probable cause
These diagnosis codes are output if communication between the side impact sensor (L.H.) and the SRS-ECU is not possible (code No.93) or abnormal (code No.79).	<ul style="list-style-type: none"> • Malfunction of harness or connector • Malfunction of side impact sensor (L.H.) • Malfunction of SRS-ECU

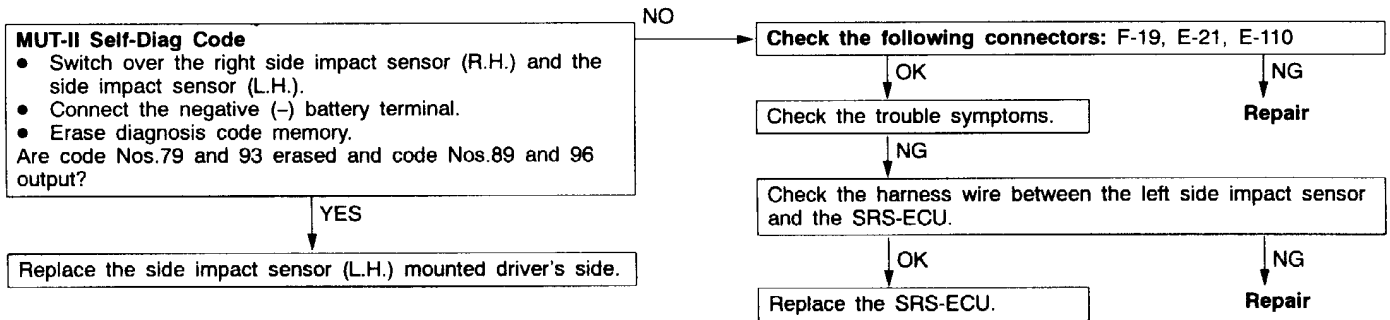

Code No.81, 82, 85, 86 Side air bag module (L.H.) (squib) system	Probable cause
These diagnosis codes are output if there is an abnormal resistance between the input terminals of the side air bag module (L.H.) (squib) inside the SRS-ECU. The trouble causes for each diagnosis code No. are as follow. However, as for code No.81, 82, if the vehicle condition returns to normal, the SRS warning lamp will go out. (Diagnosis code will remain stored)	<ul style="list-style-type: none"> • Malfunction of harness or connector • Malfunction of side air bag module (L.H.) (squib) • Malfunction of SRS-ECU

Table 6

Code No.	Trouble Symptom
81	Short in side air bag module (L.H.) (squib) or harness short
82	<ul style="list-style-type: none"> • Open circuit in side air bag module (L.H.) (squib) or open harness • Poor connector contact
85	Short in side air bag module (L.H.) (squib) harness leading to the power supply harness
86	Short in side air bag module (L.H.) (squib) harness leading to the earth

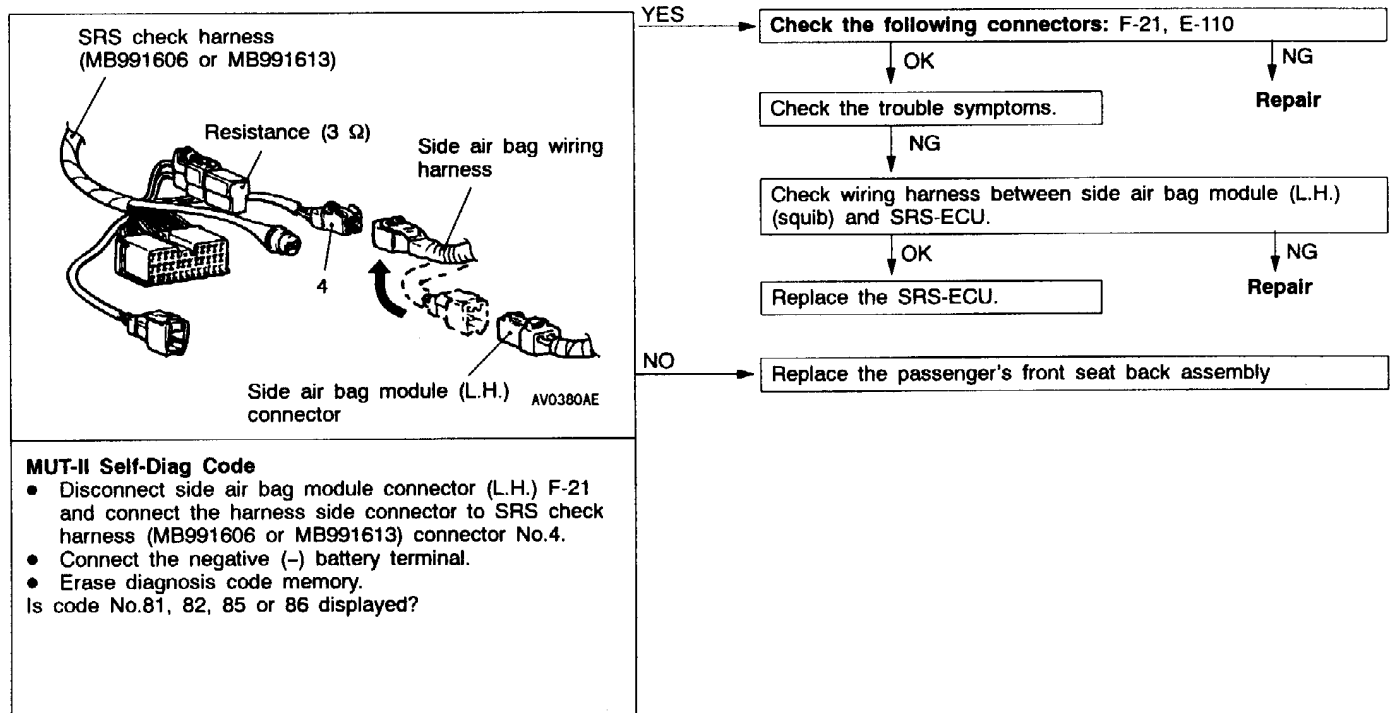

Code No.89, 96 Side impact sensor (R.H.) communication system	Probable cause
These diagnosis codes are output if communication between the side impact sensor (R.H.) and the SRS-ECU is not possible (code No.96) or abnormal (code No.89).	<ul style="list-style-type: none"> • Malfunction of harness or connector • Malfunction of side impact sensor (R.H.) • Malfunction of SRS-ECU

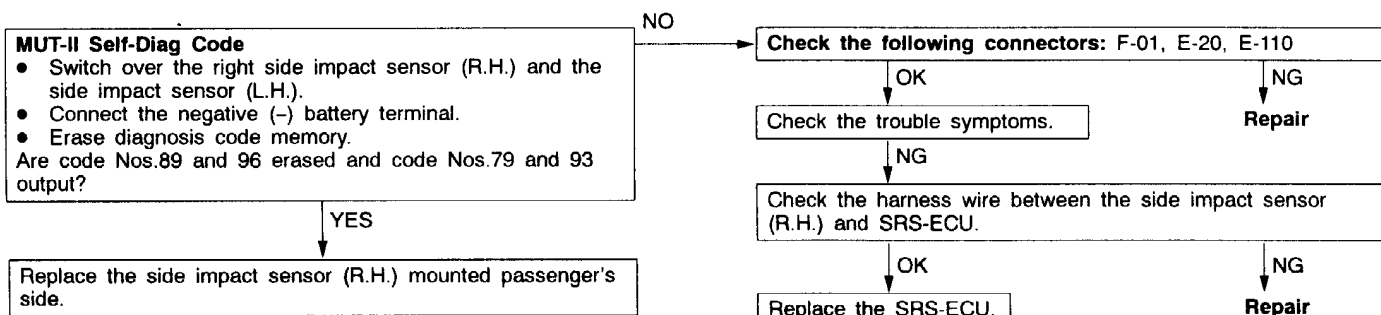

Code No.91 Side impact sensor (L.H.) power supply circuit system	Probable cause
Power supply voltage of side impact sensor (L.H.) is lower than specified for five successive seconds or more. However, when vehicle condition returns to normal, this code will be automatically erased, and the SRS warning lamp will go out.	<ul style="list-style-type: none"> • Malfunction of harness or connector • Malfunction of side impact sensor (L.H.) • Malfunction of SRS-ECU

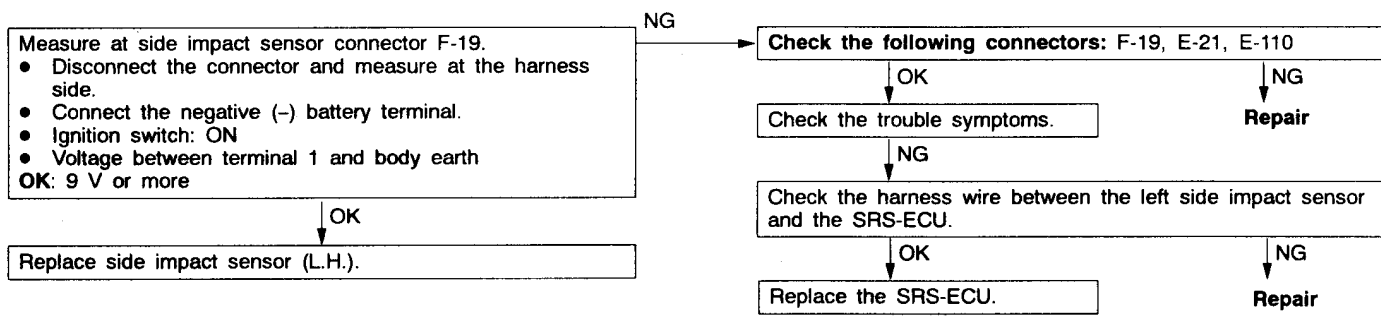

Code No.92, 95 Side impact sensor system	Probable cause
Code No.92 is displayed when malfunction is present inside side impact sensor (L.H.). Code No.95 is displayed when malfunction is present inside side impact sensor (R.H.). The trouble causes for each diagnosis code No. are as follows.	<ul style="list-style-type: none"> • Malfunction of side impact sensor (L.H.) (in case of code No.92) • Malfunction of side impact sensor (R.H.) (in case of code No.95)

Table 7

Code No.	Defective part	Trouble Symptom
92	Side impact analog G-sensor	<ul style="list-style-type: none"> • Not working • Having abnormal characteristics • Having abnormal output
95		

- Replace the side impact sensor (L.H.) (in case of code No.92)
- Replace the side impact sensor (R.H.) (in case of code No.95)

Code No.94 Side impact sensor (R.H) power supply circuit system	Probable cause
Power supply voltage of side impact sensor (R.H.) is lower than specified for consecutive five seconds or more. However, when vehicle condition returns to normal, this code will be automatically erased, and the SRS warning lamp will go out.	<ul style="list-style-type: none"> • Malfunction of harness or connector • Malfunction of side impact sensor (R.H.) • Malfunction of SRS-ECU

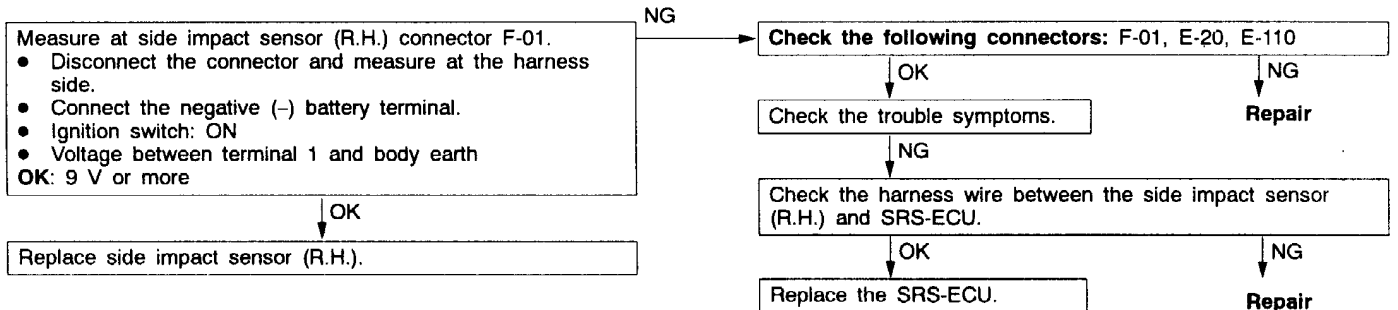

INSPECTION CHART FOR TROUBLE SYMPTOMS

Trouble Symptom	Inspection procedure No(s).	Reference page
Communication with the MUT-II is not possible.	1	52B-18
SRS warning lamp does not come on.	See diagnosis code No.43.	52B-14
SRS warning lamp does not go out.	See diagnosis code Nos.43, 44.	52B-14

INSPECTION PROCEDURES FOR TROUBLE SYMPTOMS

Inspection procedure 1

Communication with the MUT-II is not possible.	Probable cause
If communication with all other systems is not possible, there is a high possibility that there is a malfunction of the diagnosis line. When only communication with SRS air bags is impossible, open in diagnosis output circuit or power supply circuit including earth circuit may be present.	<ul style="list-style-type: none"> • Malfunction of harness or connector • Malfunction of SRS-ECU

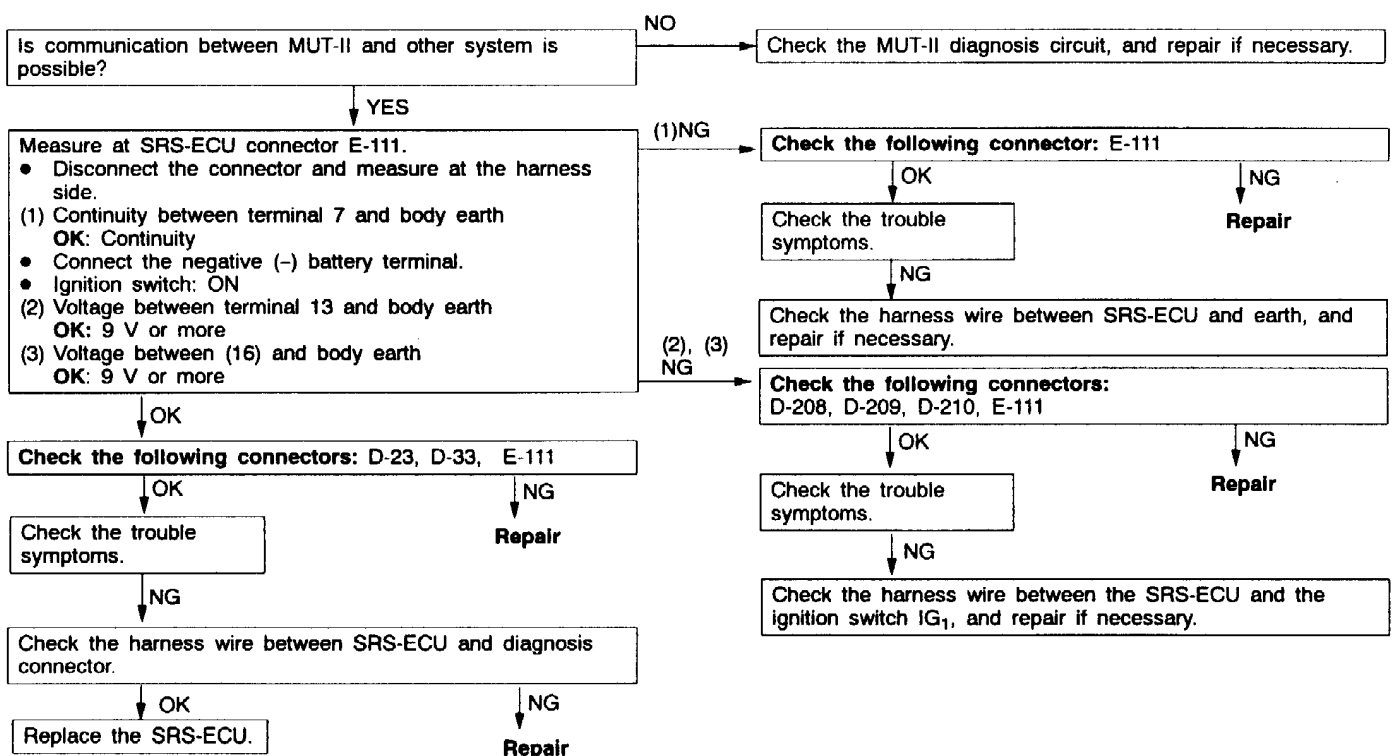

SRS MAINTENANCE

The SRS must be inspected by an authorized dealer 10 years after the date of vehicle registration.

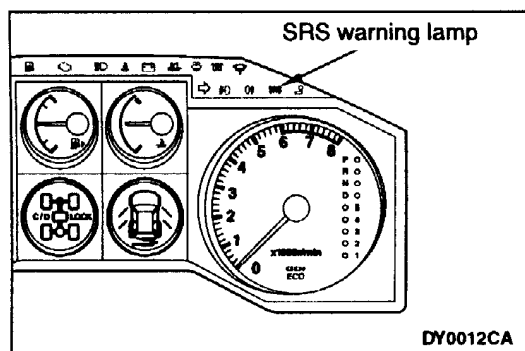

SRS WARNING LAMP CHECK

Turn the ignition key to the ON position. Does the SRS warning lamp illuminate for about 7 seconds, turn off and then remain extinguished for at least 5 seconds? If yes, SRS system is functioning properly. If no, consult page 52B-7.

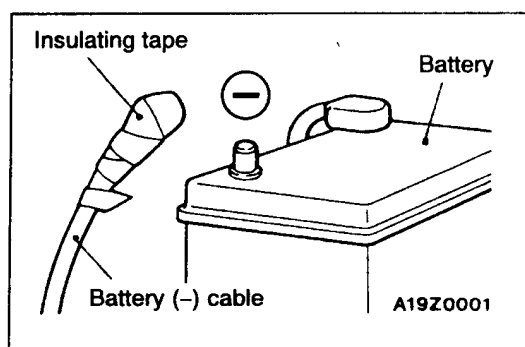

SRS COMPONENT VISUAL CHECK

Turn the ignition key to the LOCK position, disconnect the negative battery cable and tape the terminal.

Caution

Wait at least 60 seconds after disconnecting the battery cable before doing any further work. (Refer to P.52B-4.)

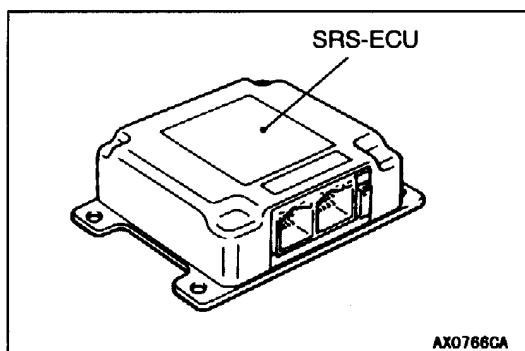

SRS CONTROL UNIT (SRS-ECU)

1. Check SRS-ECU case and brackets for dents, cracks, deformation or rust.

Caution

The SRS may not activate if the SRS-ECU is not installed properly, which could result in serious injury or death to the vehicle's driver or front passenger.

2. Check connector for damage, and terminals for deformation or rust.
Replace SRS-ECU if it fails visual check.
(Refer to P.52B-30.)

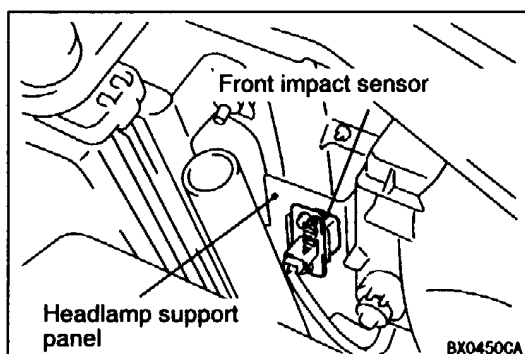

FRONT IMPACT SENSORS

1. Check the headlamp support panel for deformation or rust.
2. Check the front impact sensor for dents, cracks, deformation or rust.
3. Check the sensor harnesses for binding, the connectors for damage, and the terminals for deformation.

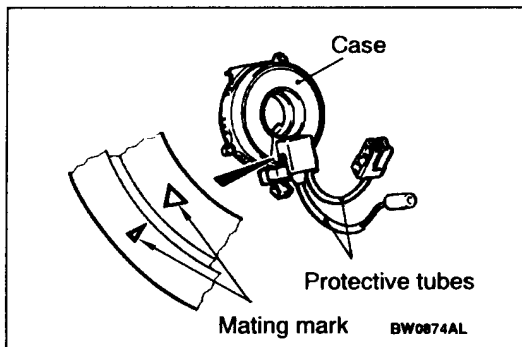
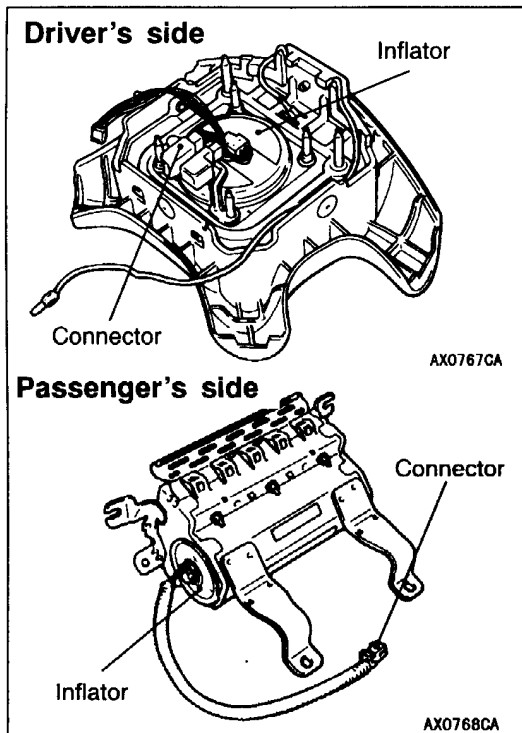

AIR BAG MODULES, STEERING WHEEL AND CLOCK SPRING

1. Remove the air bag modules, steering wheel and clock spring. (Refer to P.52B-32.)

Caution

The removed air bag modules should be stored in a clean, dry place with the pad cover face up.

2. Check pad cover for dents, cracks or deformation.
3. Check connector for damage, terminal deformities, and harness for binds.
4. Check air bag inflator case for dents, cracks or deformities.
5. Check harness and connectors for damage, and terminals for deformation.

6. Check clock spring connectors and protective tube for damage, and terminals for deformation.
7. Visually check the clock spring case for damage.
8. Align the mating marks of the clock spring and, after turning the vehicle's front wheels to straight-ahead position, install the clock spring to the column switch.

Mating Mark Alignment

Turn the clock spring clockwise fully, and then turn back it approx. 3 turns counterclockwise to align the mating marks.

Caution

If the clock spring's mating mark is not properly aligned, the steering wheel may not be completely rotational during a turn, or the flat cable within the clock spring may be severed, obstructing normal operation of the SRS and possibly leading to serious injury to the vehicle's driver or front passenger.

9. Install the steering column covers, steering wheel and the air bag module.
 10. Check steering wheel for noise, binds or difficult operation.
 11. Check steering wheel for excessive free play.
- REPLACE ANY VISUALLY INSPECTED PART IF IT FAILS THAT INSPECTION. (Refer to P.52B-38.)

Caution

The SRS may not activate if any of the above components is not installed properly, which could result in serious injury or death to the vehicle's driver or front passenger.

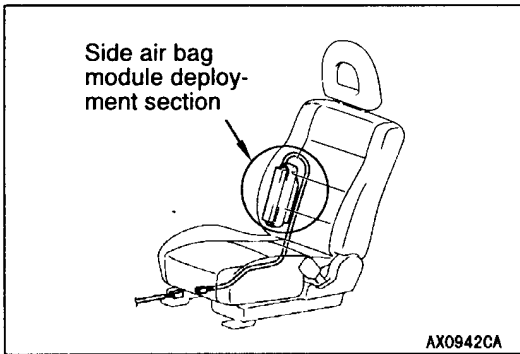

FRONT SEAT BACK ASSEMBLY (SIDE AIR BAG MODULE)

1. Check the side air bag module deployment section in the seat for dents and deformation.
2. Check the harness for binds, the connector for damage and the terminals for deformation.

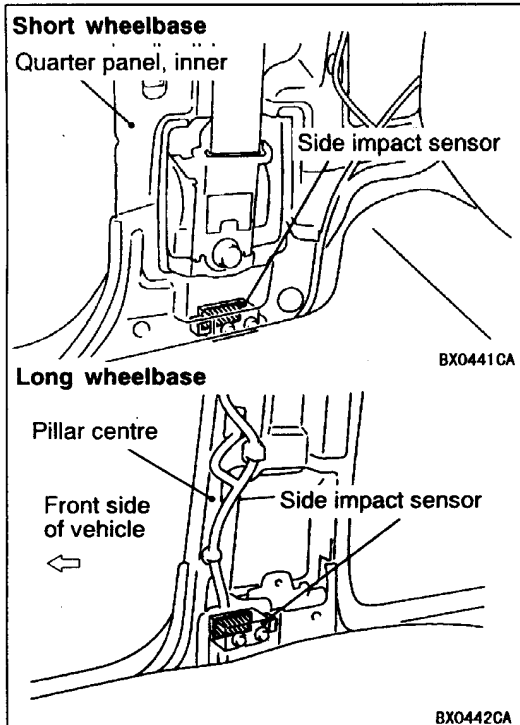

SIDE IMPACT SENSOR

1. Check the center pillar <long wheelbase> or quarter panel inner <short wheelbase> for deformation or rust.
2. Check the side impact sensors for dents, cracks, deformation and rust.
3. Check the connector for damage and the terminals for deformation.

NOTE

The figures show side impact sensors (R.H.). The side impact sensors (L.H.) is symmetrical with the side impact sensors (R.H.).

Caution

The SRS may not activate if the impact sensors are not installed properly, which could result in serious injury or death to the vehicle's driver or front passenger.

INSTRUMENT PANEL WIRING HARNESS/FRONT WIRING HARNESS/SIDE AIR BAG WIRING HARNESS/FLOOR WIRING HARNESS

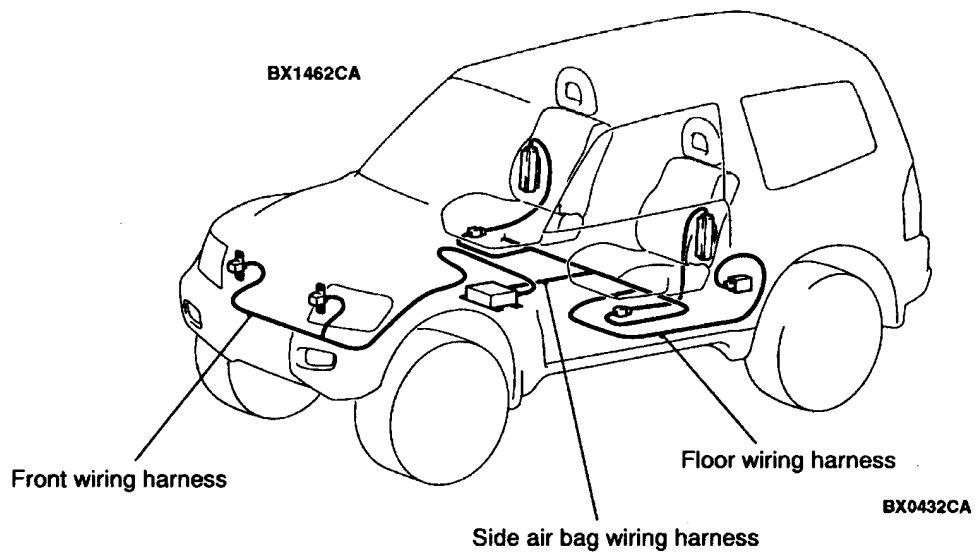
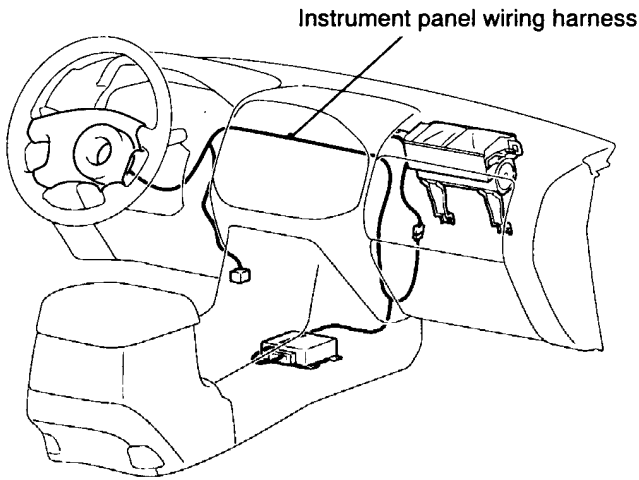

1. Check connector for poor connection.
2. Check harnesses for binds, connectors for damage, and terminals for deformation.
FAIL THE VISUAL INSPECTION. (Refer to P.52B-4.)

Caution

The SRS may not activate if SRS harnesses or connectors are damaged or improperly connected, which could result in serious injury or death to the vehicle's driver or front passenger.

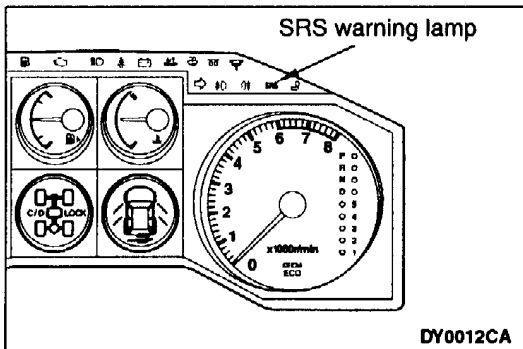

POST-INSTALLATION INSPECTION

Reconnect the negative battery terminal. Turn the ignition key to the ON position. Does the SRS warning lamp illuminate for about 7 seconds, turn off and then remain extinguished for at least 5 seconds? If yes, SRS system is functioning properly. If no, consult page 52B-7.

POST-COLLISION DIAGNOSIS

Whether or not the air bags have deployed, check and service the vehicle after collision as follows:

SRS-ECU MEMORY CHECK

1. Connect the MUT-II to the diagnosis connector. (Refer to GROUP 00 – How to Use Troubleshooting/Inspection Service Points.)

Caution

Refer to that the ignition switch is LOCK(OFF) when connecting or disconnecting MUT-II.

2. Read (and write down) all displayed diagnosis codes. (Refer to P.52B-7.)

NOTE

If battery power supply has been shut down by the collision, the MUT-II cannot communicate with the SRS-ECU. Check and, repair if necessary, the instrument panel wiring harness before the next job.

3. Use the the MUT-II to read the data list (how long trouble(s) have continued and how often memory have been erased).

Data list

No	Service Data Item	Applicability
92	Number indication how often the memory is cleared.	Maximum time to be stored: 250
93	How long problem have lasted (How long it takes from the occurrence of the problem till the first air bag squib igniting signal)	Maximum time to be stored: 9999 minutes (approximately 7 days)
94	How long problem(s) have lasted (How long it takes from the first air bag squib igniting signal till now.)	

4. Erase the diagnosis codes and after waiting 5 seconds or more read (and write down) all displayed diagnosis codes. (Refer to P.52B-7.)

REPAIR PROCEDURE

DEPLOYED DRIVER'S AND FRONT PASSENGER'S AIR BAGS

1. Replace the following parts with new ones.
 - SRS-ECU (Refer to P.52B-30.)
 - Driver's air bag module (Refer to P.52B-32.)
 - Front passenger's air bag module (Refer to P.52B-32.)
2. Check the following parts and replace if malfunction is found:
 - Clock spring (Refer to P.52B-32.)
 - Steering wheel, steering column and intermediate joint
 - (1) Check the wiring harness (built into steering wheel) and connectors for damage, and terminals for deformation.
 - (2) Check the driver's air bag module for proper installation to the steering wheel.

- (3) Check the steering wheel for noise, binds or difficult operation and excessive free play.
3. Check the harness for binding, connectors for damage, poor connections, and terminals for deformation. (Refer to P.52B-4.)

DEPLOYED SIDE AIR BAGS

1. Replace the following parts with new ones:
 - SRS-ECU (Refer to P.52B-30.)
 - Side impact sensors (Refer to P.52B-41.)
 - Front seat back assemblies (Refer to P.52B-32.)
2. Check harnesses for binding, connectors for damage, poor connections, and terminals for deformation. (Refer to P.52B-4.)

UNDEPLOYED AIR BAGS IN LOW-SPEED COLLISION

Check the SRS components. If visible damage such as dents, cracks, or deformation are found on the SRS components, replace them with new ones. Concerning parts removed for inspection, replacement with new parts and cautions in working, refer to INDIVIDUAL COMPONENT SERVICE, P.52B-26

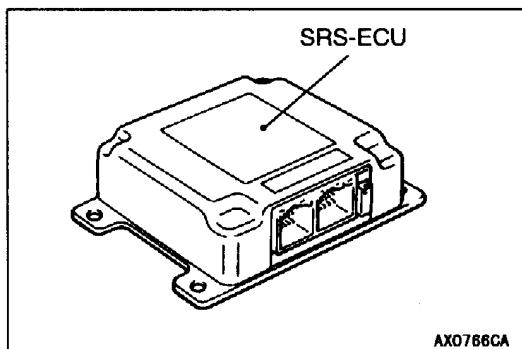

SRS-ECU

1. Check the SRS-ECU case and bracket for dents, cracks or deformation.
2. Check connectors for damage, and terminals for deformation.
3. Check the SRS-ECU and bracket for installation condition.

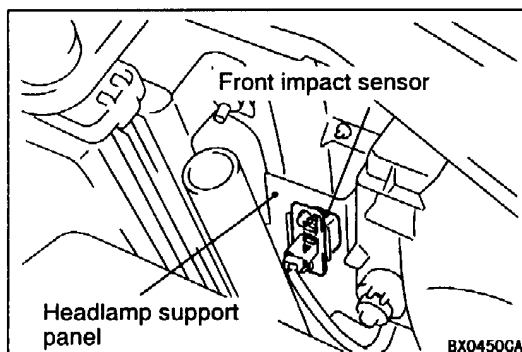

Front impact sensor

1. Check the headlamp support panel for deformation or rust.
2. Check the front impact sensor for dents, cracks, deformation or rust.
3. Check the sensor harness for binding, the connectors for damage, and the terminals for deformation.

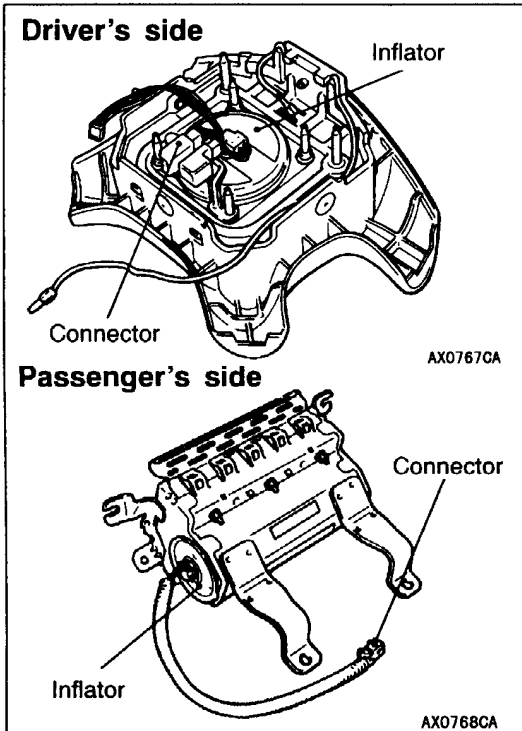

Driver's and passenger's air bag modules

1. Check the pad cover for dents, cracks or deformation.
2. Check the connectors for damage, the terminals for deformation, and the harness for binds.
3. Check the air bag inflator cases for dents, cracks or deformation.
4. Check the air bag modules for proper installation.

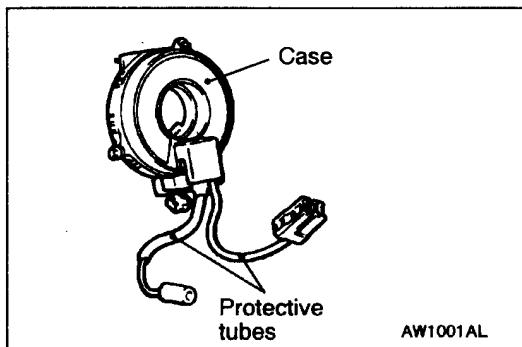

Clock spring

1. Check the connectors and protective tubes for damage and terminals for deformation.
2. Visually check the case for damage.

Steering wheel, steering column and lower shaft assembly

1. Check the driver's air bag module for proper installation to the steering wheel.
2. Check steering wheel for noise, binds or difficult operation and excessive free play.

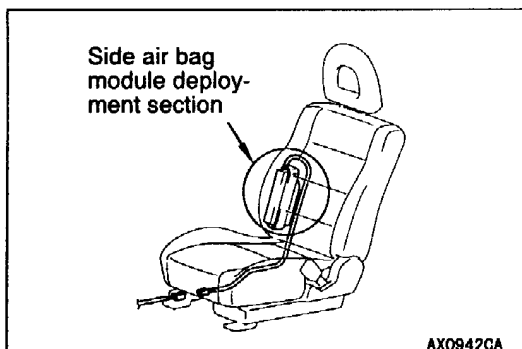

Front seat back assembly (side air bag module)

1. Check the side air bag module deployment section in the seat for dents and deformation.
2. Check the connectors for damage, the terminals for deformation, and the harness for binds.

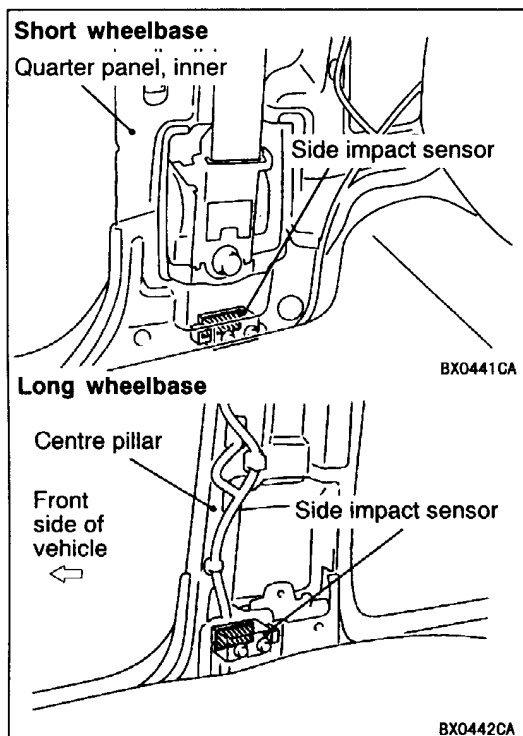

Side impact sensor

1. Check the center pillar <long wheelbase> or quarter panel inner <short wheelbase> for deformation or rust.
2. Check the side impact sensor for dents, cracks, deformation and rust.
3. Check connectors for damage, and terminals for deformation.

NOTE

The figures show side impact sensors (R.H.).The side impact sensors (L.H.) is symmetrical with the side impact sensors (R.H.).

Harness connectors (Instrument panel wiring harness, side air bag wiring harness, floor wiring harness)

Check harnesses for binding, connectors for damage and terminals for deformation.(Refer toP.52B-4.)

INDIVIDUAL COMPONENT SERVICE

If the SRS components are to be removed or replaced as a result of maintenance, troubleshooting etc., follow the service procedures that follow. (P.52B-28 to 42.)

Caution

1. SRS components should not be subjected to temperature over 93°C, so remove the SRS-ECU, front impact sensors, driver's and front passenger's air bag modules, clock spring, side impact sensors and front seat assemblies (side air bag modules) before drying or baking the vehicle after painting.
2. If the SRS components are removed for the purpose of check, sheet metal repair, painting, etc., they should be stored in a clean, dry place until they are reinstalled.

WARNING/CAUTION LABELS

Caution labels on the SRS are attached in the vehicle as shown. Follow label instructions when

servicing the SRS. If the label(s) are dirty or damaged, replace with new one(s).

Steering wheel

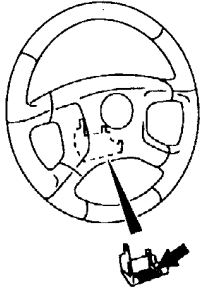

AX0433CA

Driver's air bag module

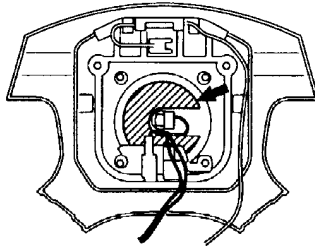

AX0434CA

Clock spring

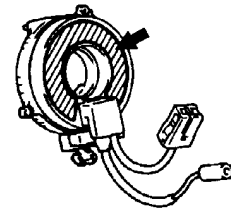

BW0963AL

Passenger's air bag module

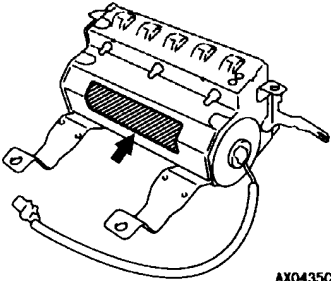

AX0435CA

SRS-ECU

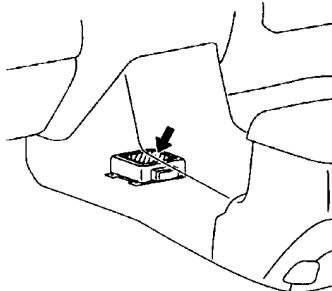

AX0436CA

Sun visor

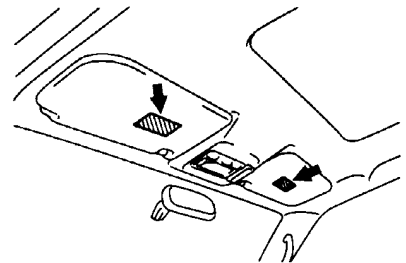

AX0437CA

Steering gear box

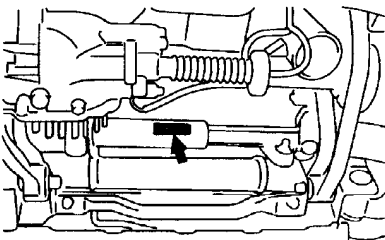

AX0438CA

Side air bag (driver's and passenger's sides)

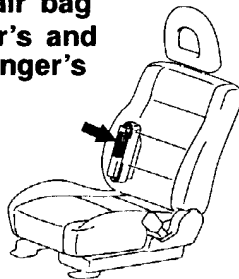

AX0439CA

Hood

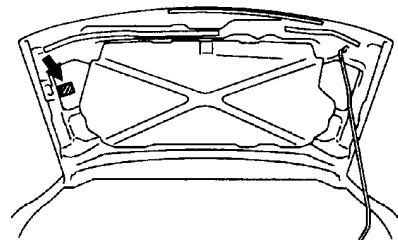

AX0440CA

Side impact sensor Short wheelbase

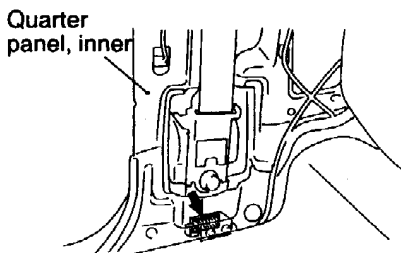

AX0441CA

Long wheelbase Center pillar

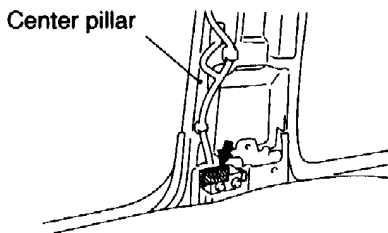

AX0442CA

Front impact sensor

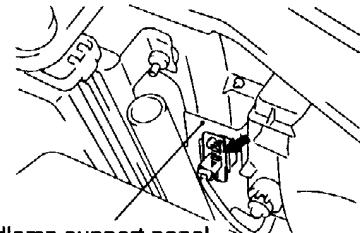

AX0450CA

Instrument panel

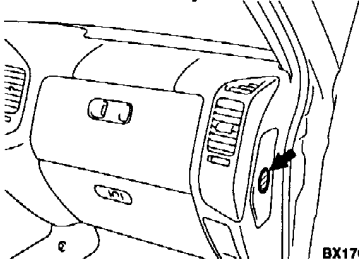

BX1709CA

Glove box

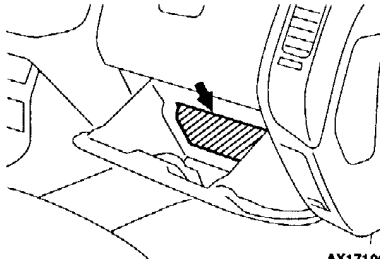

AX1710CA

Headlamp support panel

FRONT IMPACT SENSORS

Caution

1. Disconnect the battery (-) terminal and wait for 60 seconds or more before starting work. Furthermore, the disconnected battery terminal should be covered with tape to insulate it. (Refer to P.52B-4.)
2. Never attempt to disassemble or repair the front impact sensor. If faulty, replace it.
3. Do not drop or subject the front impact sensor to impact or vibration. If denting, cracking, deformation, or rust are discovered in the front impact sensor, replace it with a new front impact sensor. Discard the old one.
4. After deployment of an air bag, replace the front impact sensor with a new one.

REMOVAL AND INSTALLATION

Pre-removal Operations

- Turn the ignition switch to LOCK(OFF) position.
- Disconnect the negative battery (-) terminal.

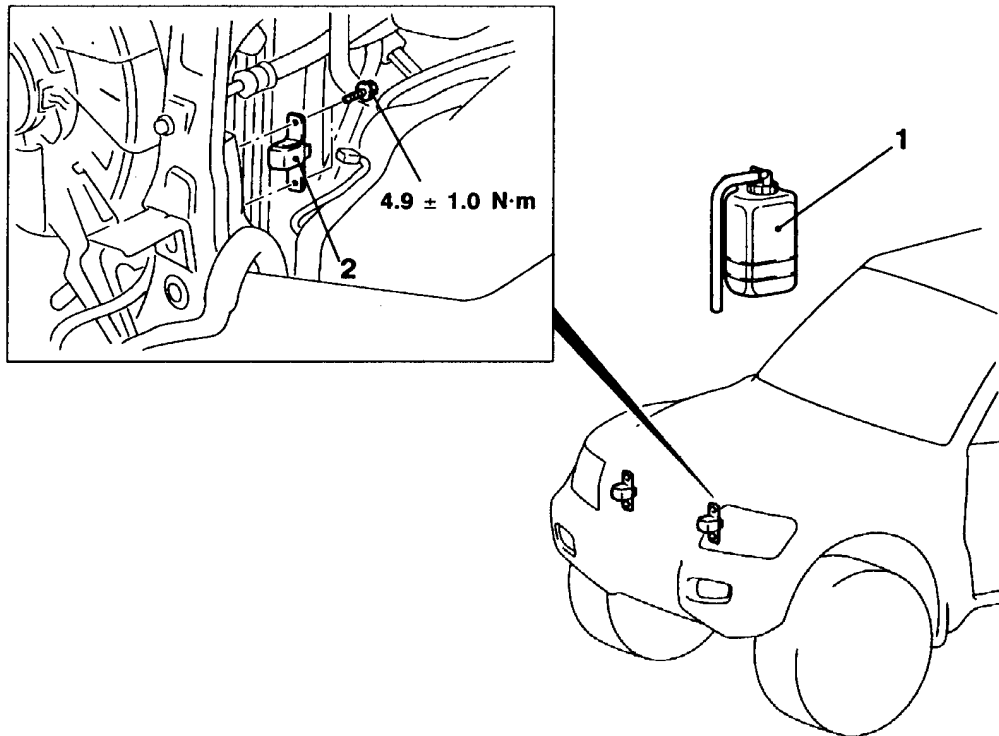

AX0773CA

Removal steps

1. Condense tank
2. Front impact sensor

Installation steps

- ▶A◀ • Pre-installation inspection
- ▶B◀ 2. Front impact sensor
 1. Condense tank
 - Connect the negative (-) battery terminal.
- ▶C◀ • Post-installation inspection

NOTE

The figure shows the front impact sensor (L.H.).

INSTALLATION SERVICE POINTS

►A◄ PRE-INSTALLATION INSPECTION

To mount the new front impact sensor, visually check it and measure the resistance between the terminals. (Refer to the previous item "INSPECTION".)

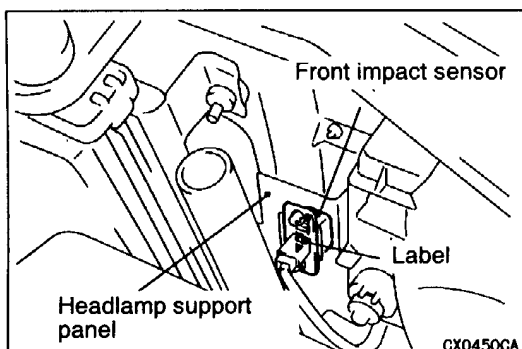

►B◄ FRONT IMPACT SENSOR INSTALLATION

1. Securely connect the connector.
2. Position the front impact sensor facing toward the front of the vehicle as shown by the arrow on the label and install it securely.

Caution

The SRS may not activate properly if a front impact sensor is not installed properly.

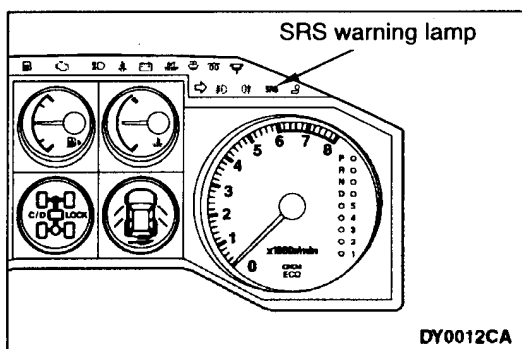

►C◄ POST-INSTALLATION INSPECTION

1. Turn the ignition key to the ON position.
2. Does the SRS warning lamp illuminate for about 7 seconds, and then remain extinguished for at least 5 seconds after turning OFF?
3. If no, refer to troubleshooting. (Refer to P.52B-7)

INSPECTION

1. Check the front impact sensor for dents, cracks, deformation or rust.

Caution

If a dent, crack, deformation or rust is found, replace the sensor with a new one.

2. Check short or open circuit between the terminals of the front impact sensor.

Short circuit: 1 Ω or less

Open circuit: 1 M Ω or more

Caution

Always replace the sensor with a new one if the resistance shows a short or open circuit.

3. Check the continuity between the terminal and bracket. If there is a continuity, the insulation is malfunctioned, and replace the sensor with a new one.
4. Check the headlamp support panel for deformation and rust.

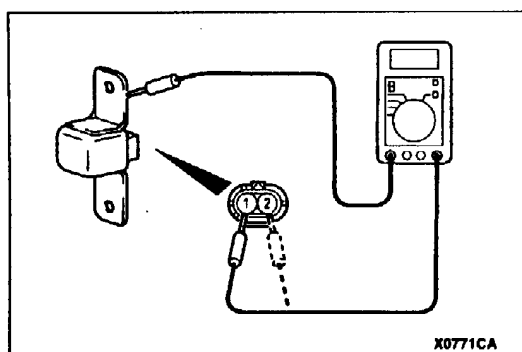
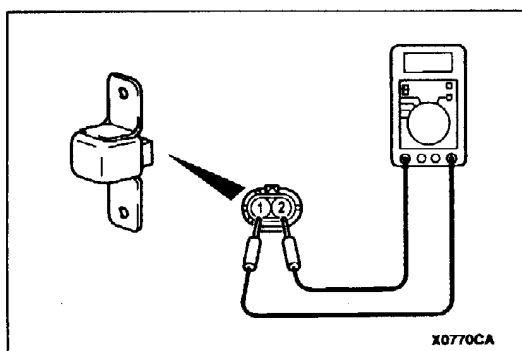

SRS AIR BAG CONTROL UNIT (SRS-ECU)

Caution

1. Disconnect the negative (–) battery terminal and wait for 60 seconds or more before starting work. Also, the disconnected battery terminal should be insulated with tape. (Refer to P.52B-4.)
2. Never attempt to disassemble or repair the SRS-ECU. If faulty, just replace with a new one.
3. Do not drop or subject the SRS-ECU to impact or vibration. If denting, cracking, deformation, or rust are found in the SRS-ECU, replace it with a new one. Discard the old one.
4. After deployment of the air bags, replace the SRS-ECU with a new one.
5. Never use an ohmmeter on or near the SRS-ECU, and use only the special test equipment described on P.52B-7.

REMOVAL AND INSTALLATION

Pre-removal Operations

- Turn the ignition switch to LOCK(OFF) position.
- Disconnect the negative battery (–) terminal.

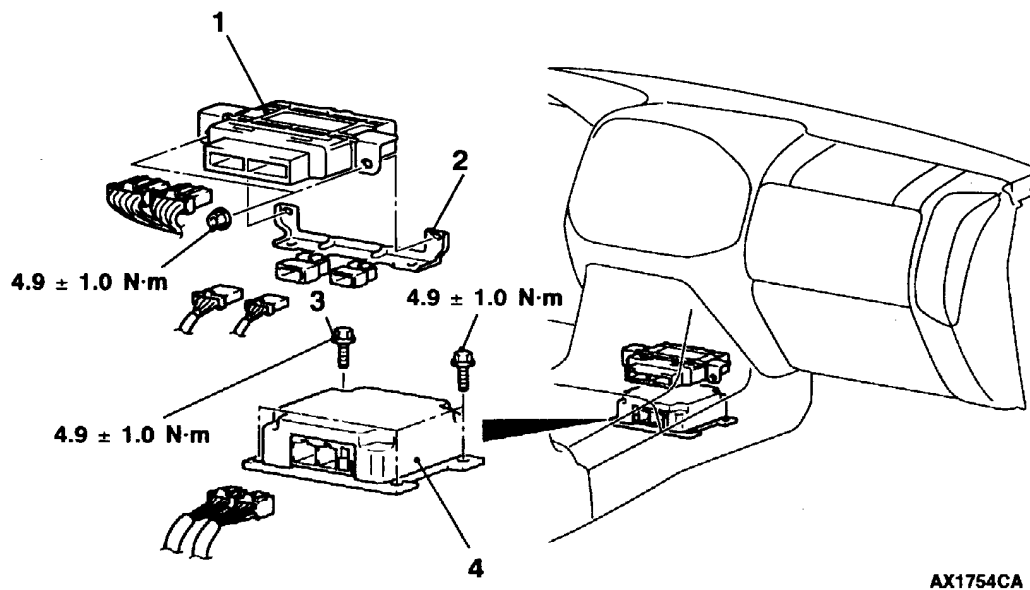

AX1754CA

Removal steps

- Front floor console (Refer to GROUP 52A.)
- 1. Transfer-ECU
- 2. Connector bracket
- 3. SRS-ECU mounting bolts (earth bolt)
- 4. SRS-ECU

Installation steps

- ▶A◀ 4. SRS-ECU
- ▶B◀ 3. SRS-ECU mounting bolts (earth bolt)
- 2. Connector bracket
- 1. Transfer-ECU
- Front floor console (Refer to GROUP 52A.)
- Connect the negative (–) battery terminal.
- ▶C◀ • Post-installation inspection

INSTALLATION SERVICE POINTS**▶A◀ SRS-ECU INSTALLATION****Caution**

The SRS may not activate if SRS-ECU is not installed properly.

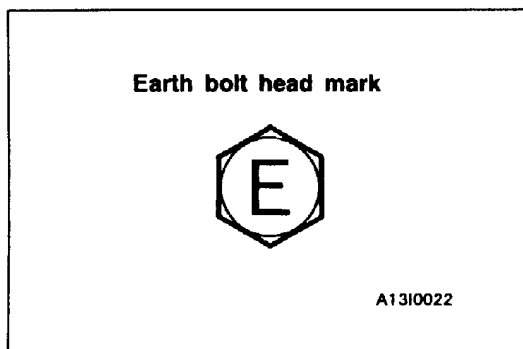
**▶B◀ SRS-ECU MOUNTING BOLT (EARTH BOLT) INSTALLATION**

Before installation, check that the bolt is stamped mark "E" on the head.

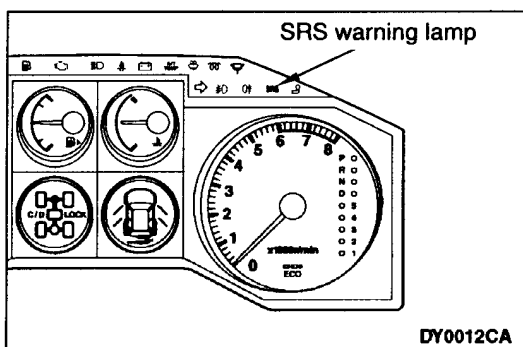
**▶C◀ POST-INSTALLATION INSPECTION**

1. Turn the ignition key to the ON position.
2. Does the SRS warning lamp illuminate for about 7 seconds, and then remain extinguished for at least 5 seconds after turning OFF?
3. If no, refer to troubleshooting.
(Refer to P.52B-7)

INSPECTION

1. Check the SRS-ECU case for dents, cracks or deformation.
2. Check connector for damage, and terminals for deformation.

Caution

If any problems are found, replace the SRS-ECU.

NOTE

For the checks other than the items above, refer to "Troubleshooting." (Refer to P.52B-7.)

AIR BAG MODULES AND CLOCK SPRING

Caution

1. Disconnect the negative (–) battery terminal and wait for 60 seconds or more before starting work. Also, the disconnected battery terminal should be insulated with tape. (Refer to P.52B-4.)
2. Never attempt to disassemble or repair the air bag modules and clock spring. If faulty, just replace with new one(s).
3. Do not drop the air bag modules or clock spring or allow contact with water, grease or oil.
Replace if a dent, crack, deformation or rust are present.
4. Store the air bag modules on a flat surface with the deployment surface facing up. Do not place anything on top of them.
5. Do not store the air bag modules in a place more than 93°C.
6. When the driver's and front passenger's air bags have been deployed, replace the driver's and passenger's air bag modules with new ones.
7. Put on gloves and safety glasses when handling deployed air bags.
8. When discarding the undeployed air bag module(s), be sure to deploy the air bag(s) in advance as specified in the service procedure.
(Refer to to P.52B-43.)

REMOVAL AND INSTALLATION

- Pre-removal Operations**
- After setting the steering wheel and the front wheels to the straight ahead position, remove the ignition key.
 - Disconnect the negative battery (-) terminal.

<Driver's air bag module and clock spring>

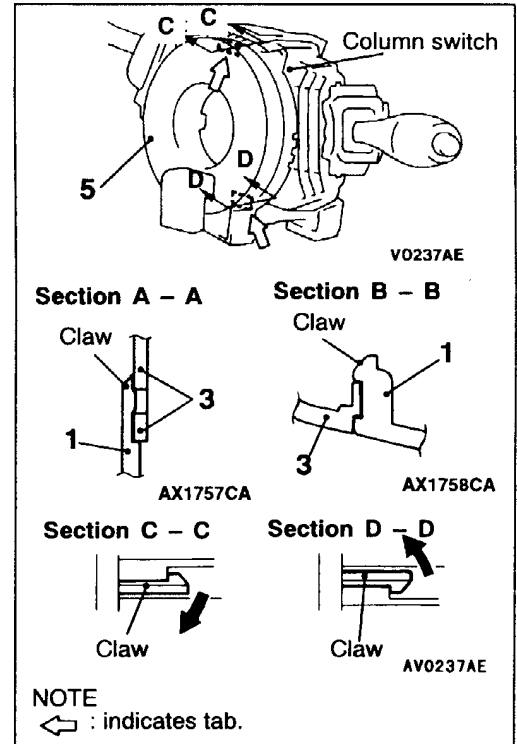
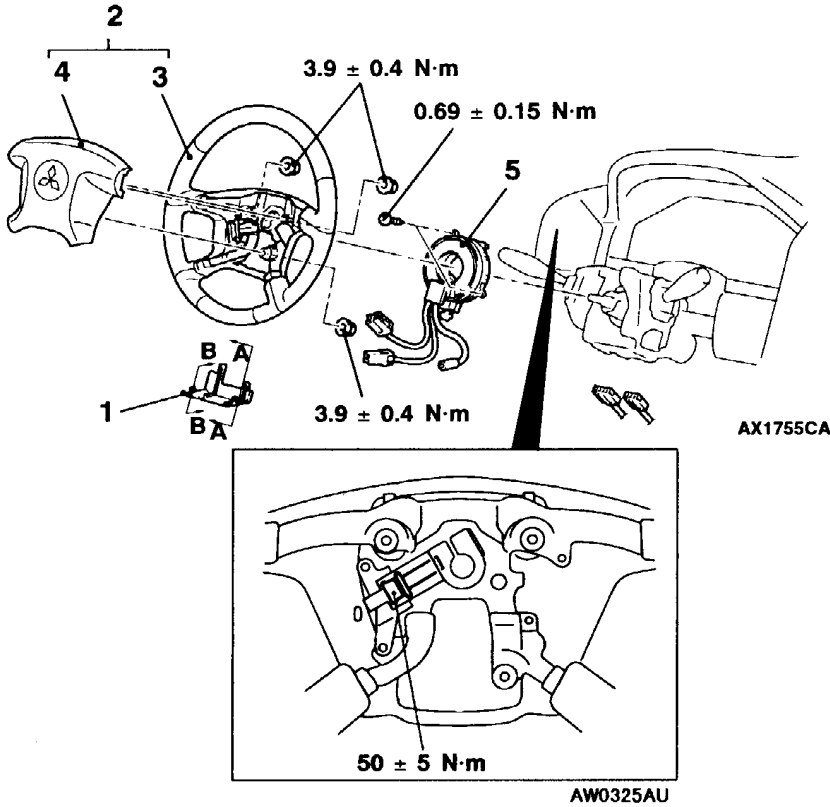

Driver's air bag module removal steps

- ▶A◀ 1. Cover
- ▶B◀ 2. Steering wheel and air bag module assembly
- ▶C◀ 3. Steering wheel
- ▶D◀ 4. Driver's air bag module

Driver's air bag module installation steps

- ▶A◀ • Pre-installation inspection
- ▶B◀ 4. Driver's air bag module
- ▶C◀ 3. Steering wheel
- ▶D◀ 2. Steering wheel and air bag module assembly
- ▶E◀ 1. Cover
- ▶F◀ • Connect the negative (-) battery terminal.
- ▶G◀ • Post-installation inspection

Clock spring removal steps

- ▶A◀ 1. Cover
- ▶B◀ 2. Steering wheel and air bag module assembly
- ▶C◀ • Lower column cover
- ▶D◀ 5. Clock spring

Clock spring installation steps

- ▶A◀ • Pre-installation inspection
- ▶B◀ 5. Clock spring
- ▶C◀ • Lower column cover
- ▶D◀ 2. Steering wheel and air bag module assembly
- ▶E◀ 1. Cover
- ▶F◀ • Connect the negative (-) battery terminal.
- ▶G◀ • Post-installation inspection

<Passenger's air bag module>

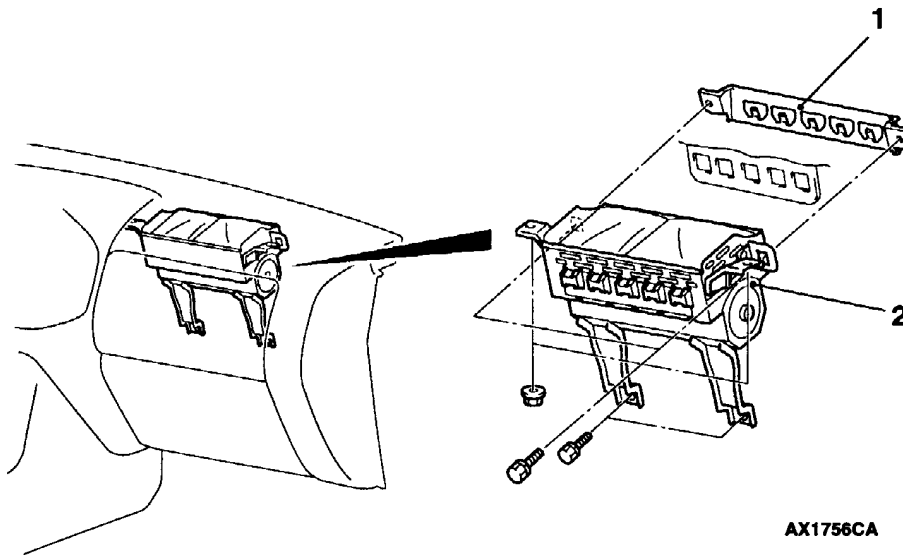

AX1756CA

Removal steps

- Upper glove box (Refer to GROUP 52A – Instrument Panel.)
 - Glove box (Refer to GROUP 52A – Instrument Panel.)
1. Air bag side plate
 2. Passenger's air bag module

Installation steps

- ▶A◀ ● Pre-installation inspection
- 2. Passenger's air bag module
- 1. Air bag side plate
- Glove box (Refer to GROUP 52A – Instrument Panel.)
- Upper glove box (Refer to GROUP 52A – Instrument Panel.)
- Connect the negative (-) battery terminal.
- ▶D◀ ● Post-installation inspection



<Front seatback assembly equipped with side air bag module>

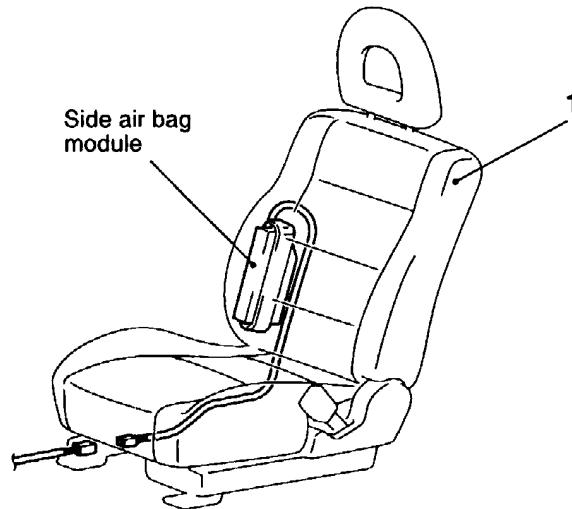

BX0942GA

Removal steps



1. Front seat back assembly

Installation steps



- Pre-installation inspection
- 1. Front seat back assembly
- Connect the negative (-) battery terminal.



- Post-installation inspection

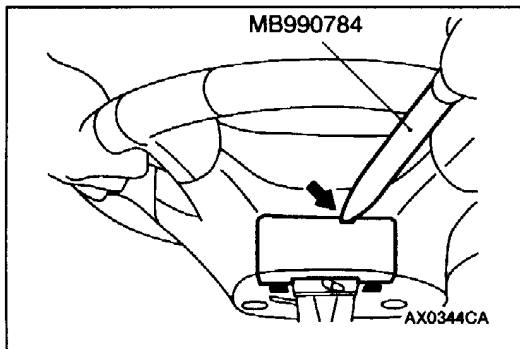

REMOVAL SERVICE POINTS

◀A▶ COVER REMOVAL

Insert the special tool as shown in the illustration to remove the cover.

NOTE

The arrow in the illustration shows the notch for the special tool.

◀B▶ STEERING WHEEL AND AIR BAG MODULE ASSEMBLY REMOVAL

1. Remove the air bag module and disconnect the horn switch connector through space produced after the removal of the steering wheel.
2. Loosen the bolt completely and then remove the steering wheel assembly.

NOTE

Use a hexagonal bit socket or a hexagonal wrench having an effective length of 75 mm or more in the hexagonal section and the diameter of 8 mm or more.

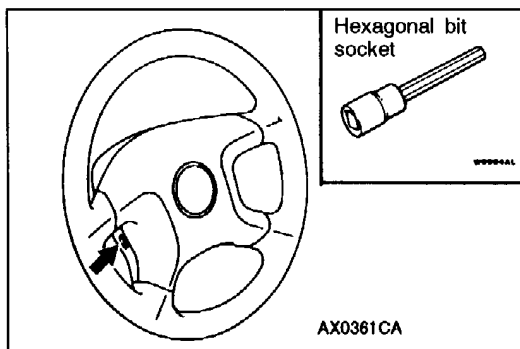

◀C▶ DRIVER'S AIR BAG MODULE REMOVAL

Caution

1. The air bag module must not be measured with such equipment as an ohmmeter, nor disassembled.
2. The removed air bag module should be stored in a clean, dry place with the deployment surface facing up.

◀D▶ CLOCK SPRING REMOVAL

Caution

The removed clock spring should be stored in a clean, dry place.

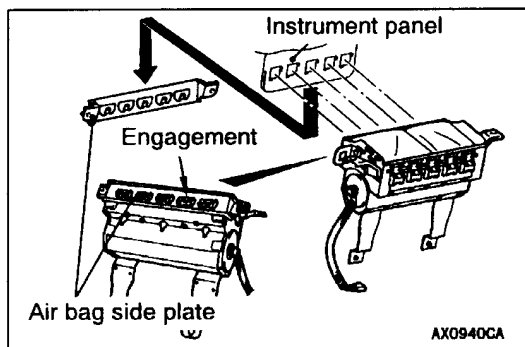

◀E▶ AIR BAG SIDE PLATE REMOVAL

1. Remove the air bag side plate mounting bolt and slide downward the air bag side plate and then disengage it from the passenger's air bag module.
2. After removal of the passenger's air bag module mounting bolt and nut, move the passenger's air bag aside and remove the air bag side plate.

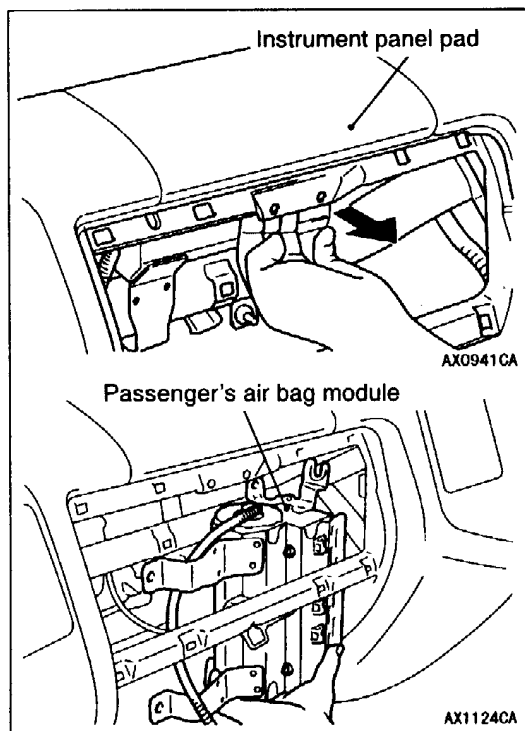

◀F▶ PASSENGER'S AIR BAG MODULE REMOVAL

While the instrument panel pad as shown in the illustration is pulled forward, remove the air bag module and pull it out from the down side.

Caution

The removed passenger's air bag module should be stored in a clean, dry place with facing the deployment surface facing up.

◀G▶ FRONT SEATBACK ASSEMBLY REMOVAL

(Refer to GROUP 52A – Seat.)

Caution

1. When the side air bag module is required replacing, replace the front seat back assembly.
2. The removed front seat back assembly should be stored in clean, dry place with its back touching the ground.

INSTALLATION SERVICE POINTS**▶A◀ PRE-INSTALLATION INSPECTION**

1. Even new air bag modules, clock spring and front seat back assembly require inspection before installation. (Refer to P.52B-38.)

Caution

When discarding the air bag module or seat back assembly, deploy the air bag as specified in the service procedure. (Refer to P.52B-43.)

2. Connect the negative (-) battery terminal.
3. Connect the MUT-II to the diagnosis connector (16 pin)

Caution

Turn the ignition switch to the LOCK (OFF) position when connecting and disconnecting the MUT-II.

4. Turn the ignition key to the ON position.
5. Read a diagnostic code to refer to that the SRS is operating properly except an open in the air bag module circuit.
6. Turn the ignition switch to LOCK(OFF) position.
7. Disconnect the negative (-) battery cable and insulate with tape.

Caution

Wait at least 60 seconds after the disconnection of the battery cable before any further job. (Refer to P.52B-4, item 5 of the Service Precautions)

▶B◀ CLOCK SPRING INSTALLATION

Align the mating marks on the clock spring as mentioned in the next step. Then, install the clock spring to the column switch.

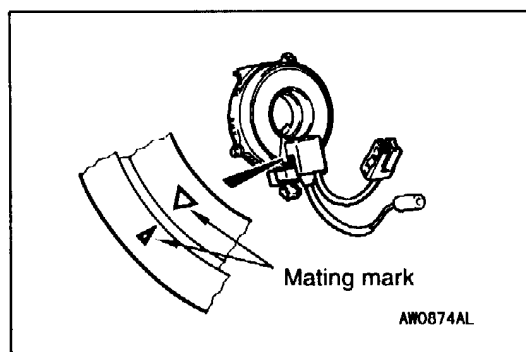
**CLOCK SPRING CENTERING**

Fully turn the clock spring clockwise and then turn it back about 3 times counterclockwise to align the mating marks.

Caution

Unless the mating marks are properly aligned, the steering wheel gets stuck amid a turn or the flat cable in the clock spring is cut. These hinder the SRS air bag from proper operation, resulting in serious injury to the vehicle's driver.

►C◄ STEERING WHEEL AND AIR BAG MODULE ASSEMBLY INSTALLATION

1. Refer to first that the clock spring has been centered properly. Then, install the steering wheel.

Caution

Be sure when installing the steering wheel, that the harness of the clock spring does not become caught or tangled.

2. After clamping, turn the steering wheel all the way in both directions to confirm that steering is normal.

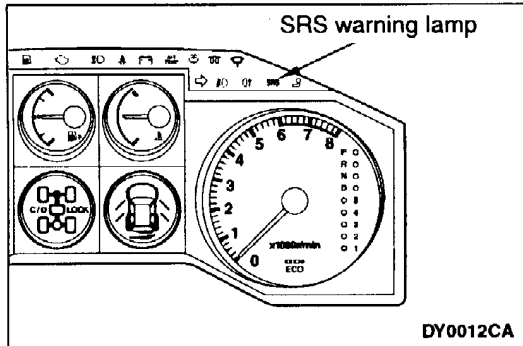

►D◄ POST-INSTALLATION INSPECTION

1. When the driver's airbag module or the clock spring is installed, turn the steering wheel clockwise and counterclockwise slowly to confirm that there is no noise or improper operation.
2. Turn the ignition key to the ON position.
3. Does the SRS warning lamp illuminate for about 7 seconds, and then remain extinguished for at least 5 seconds after turning OFF?
4. If no, refer to troubleshooting. (Refer to P.52B-7)

INSPECTION

Driver's and passenger's air bag module

If any malfunction is found in the following inspection, replace the air bag module(s) with new one(s). Discard the old one(s) after deployment as specified in the service procedure. (Refer to P.52B-43.)

Caution

Never measure circuit resistance in the air bag modules (squib) even with the specified tester. Measuring the circuit resistance with a tester causes accidental air bag deployment due to current that flows or static, resulting in serious personal injury.

1. Check the cover for dents, cracks or deformation.
2. Check the harness and connector for damage and the terminals for deformation.
3. Check the air bag inflator cases for dents, cracks or deformation.
4. Check the air bag module for proper installation.

Caution

If a dent, crack or deformation is detected, replace with a new sensor. Discard the old one(s) as specified in the service procedure. (Refer to P.52B-43.)

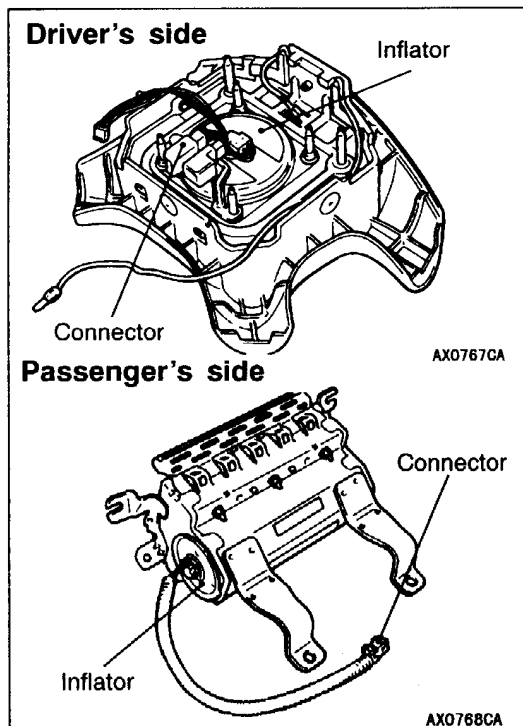

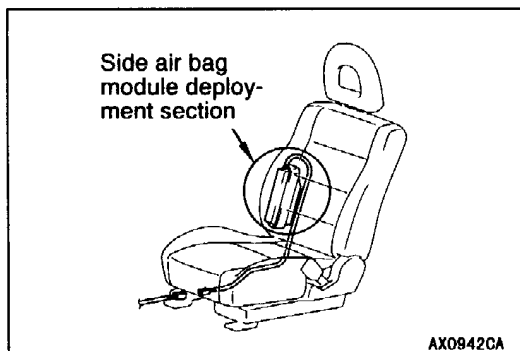
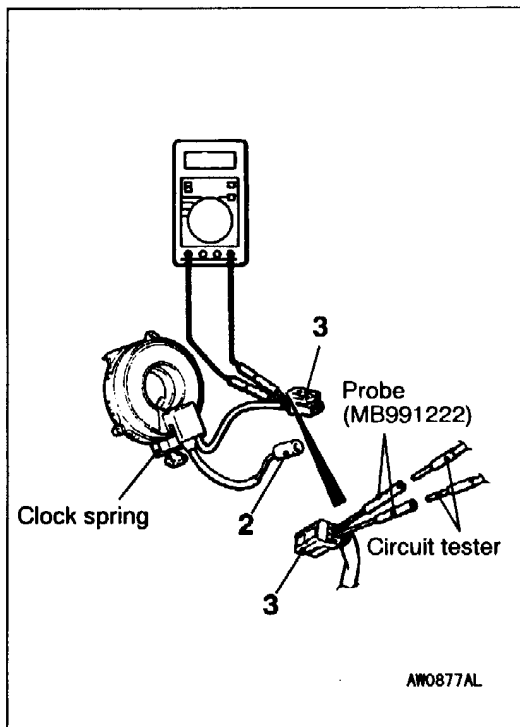
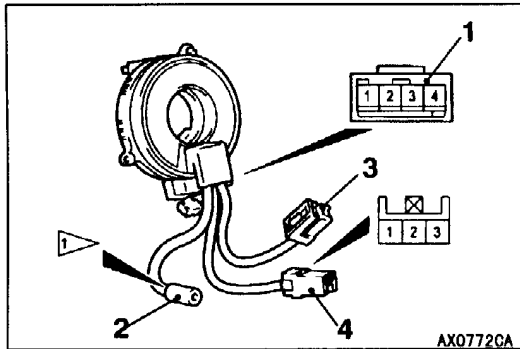
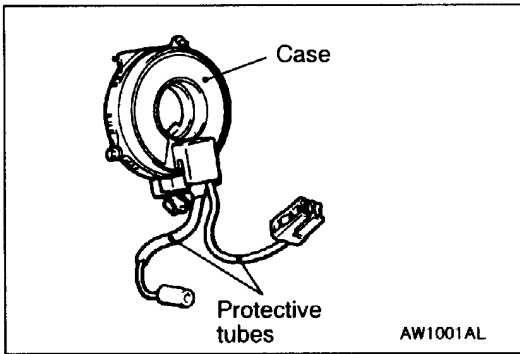

Clock spring

If any malfunction is found in the following inspections, replace the clock spring with a new one.

1. Check the connectors and protective tubes for damage, and terminals for deformation.
2. Visually check the case for damage.

3. Refer to that the clock spring has continuity between connectors No.1, No.2, No.4 <vehicles with auto-cruise control>.

Connector No.	1				2		4	
Terminal No.	1	2	3	4	1	2	3	
Continuity	○					○		
		○					○	
			○				○	
				○	○			

4. Insert the probes (MB991222) from the rear of the clock spring No.3 connector.

Caution

Never insert the probe directly to the terminals from the front of the connector.

5. Connect a digital multimeter to the probe (MB991222) as shown, to check that the resistance is 1 Ω or less. Also, check that there is a open circuit.

Open circuit: 1 MΩ or more

Front seat back assembly equipped with side air bag module

If any malfunction is found in the following inspections, replace the front seat back assembly.

To discard the removed front seat back assembly, deploy the side air bag first as specified in the service procedure. (Refer to P.52B-43.)

Caution

Never measure circuit resistance in the side air bag modules (squib) even with the specified tester.

Measuring the circuit resistance with a tester causes accidental air bag deployment due to current that flows or static, resulting in serious personal injury.

1. Check the side air bag module deployment section for dents and deformation.
2. Check the harness and connector for damage and the terminals for deformation.

SIDE IMPACT SENSOR

Caution

1. Disconnect the negative (-) battery terminal and wait for 60 seconds or more before starting work. Also, the disconnected battery terminal should be insulated with tape. (Refer to P.52B-4.)
2. Never attempt to disassemble or repair the side impact sensors. If faulty, just replace with new ones.
3. Do not drop or subject the side impact sensors to impact or vibration. If denting, cracking, deformation, or rust are found in the side impact sensors, replace it with new ones. Discard the old ones.
4. After deployment of the air bags, replace the side impact sensors with new ones.
5. Never use an ohmmeter on or near the side impact sensors, and use only the special test equipment described on P.52B-7.

REMOVAL AND INSTALLATION

Pre-removal Operations

- Turn the ignition switch to LOCK(OFF) position.
- Disconnect the negative battery (-) terminal.

Short wheelbase

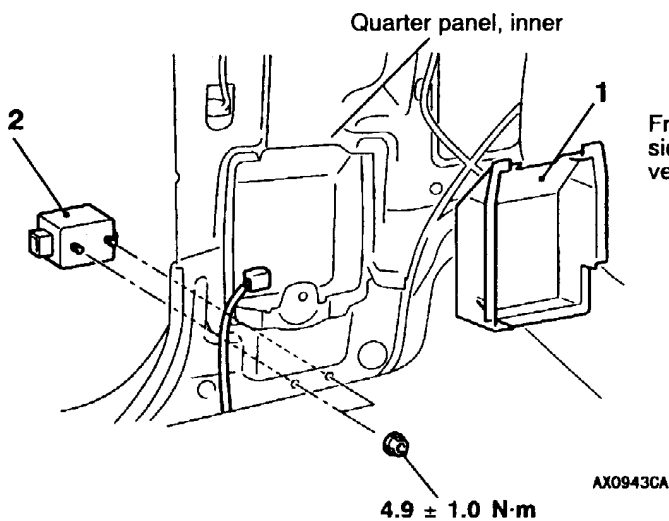

Removal steps

- Front seat belt (Refer to GROUP 52A.)
- 1. Front noise protector
- 2. Side impact sensor

Long wheelbase

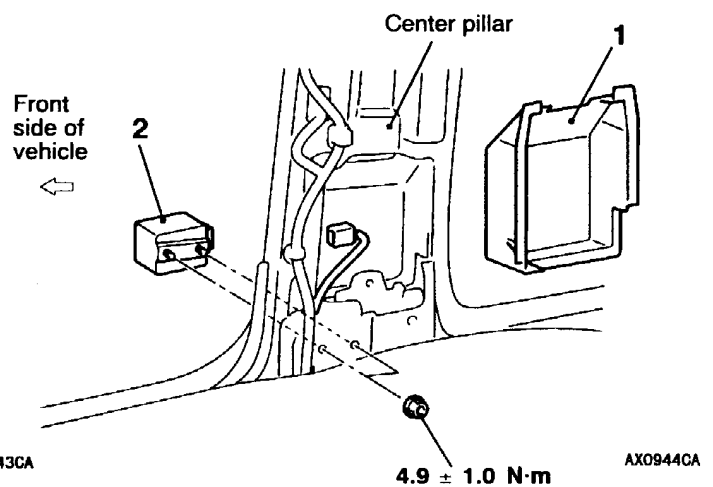

Installation steps

- ▶A◀ • Pre-installation inspection
- ▶B◀ 2. Side impact sensor
- 1. Front noise protector
- Front seat belt (Refer to GROUP 52A.)
- Connect the negative (-) battery terminal.
- ▶C◀ • Post-installation inspection

NOTE

The figure shows the side impact sensor (R.H.).

INSTALLATION SERVICE POINTS**►A◄ PRE-INSTALLATION INSPECTION**

Even new side impact sensor requires inspection before installation. (Refer to the previous item "INSPECTION".)

►B◄ SIDE IMPACT SENSOR INSTALLATION**Caution**

The side impact sensor, unless properly installed, does not operate properly, thereby resulting in serious injury or death of the vehicle's occupants.

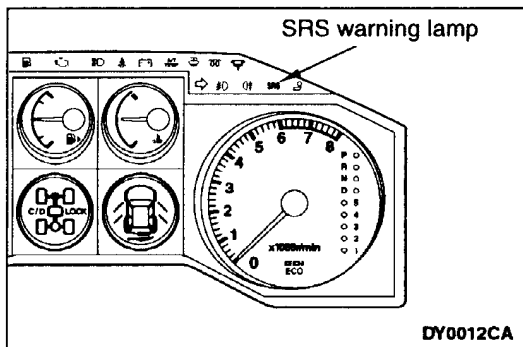
**►C◄ POST-INSTALLATION INSPECTION**

1. Turn the ignition key to the ON position.
2. Does the SRS warning lamp illuminate for about 7 seconds, and then remain extinguished for at least 5 seconds after turning OFF?
3. If no, refer to troubleshooting.
(Refer to P.52B-7)

INSPECTION

1. Check the side impact sensor for dents, cracks, deformation and rust.
2. Check connector for damage, and terminals for deformation.
3. Check the center pillar or quarter panel, inner for deformation and rust.

Caution

If a dent, crack, deformation or rust is found, replace the sensor with a new one.

NOTE

For other inspections than described above, go to Troubleshooting. (Refer to P.52B-7.)

AIR BAG MODULE DISPOSAL PROCEDURES

When discarding the air bag modules or a vehicle with SRS air bags, be sure to deploy the air bags

in advance as specified in the service procedure that follows.

UNDEPLOYED AIR BAG MODULES

Caution

1. If the vehicle is to be scrapped or otherwise disposed of, deploy the air bags inside the vehicle. If the vehicle is still to be used and only the air bag modules are to be discarded, deploy the air bags outside the vehicle.
2. Since a large amount of smoke is produced when the air bags are deployed, avoid residential areas whenever possible.
3. Since there is substantial report when the air bags are deployed, avoid residential areas whenever possible. If anyone is nearby, give warning of the impending noise.
4. Suitable ear protection must be put on by personnel performing these procedures or by people in the immediate area.

DEPLOYMENT INSIDE THE VEHICLE

1. Move the vehicle to flat and isolated spot.
2. Disconnect the negative (-) and positive (+) battery cables from the battery terminals, and then remove the battery from the vehicle.

Caution

Wait at least 60 seconds after the disconnection of the battery cables before any further job. (Refer to P.52B-4.)

3. Deploy each air bag module as specified in the service procedures that follow.

Driver's air bag module

- (1) Remove the steering column cover, lower. (Refer to GROUP 52A – Instrument Panel.)
- (2) Disconnect the clock spring 2-pin connector and instrument panel wiring harness connector (2-pin, yellow).

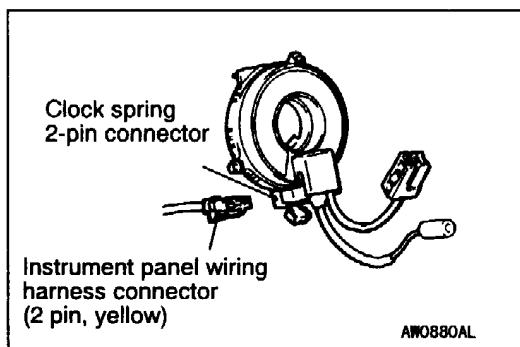

NOTE

Once disconnected from the instrument panel wiring harness, both electrodes of the clock spring connector short automatically. This prevents the driver's air bag from accidental deployment caused by static, etc.

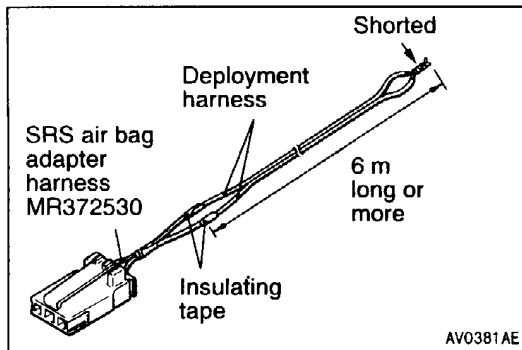

- (3) Connect deployment harnesses longer than 6 m to each SRS air bag adapter harness and insulate the connections with plastic tape. Also, connect the deployment harnesses in the other ends to short, thereby preventing the driver's air bag from accidental deployment caused by static etc.

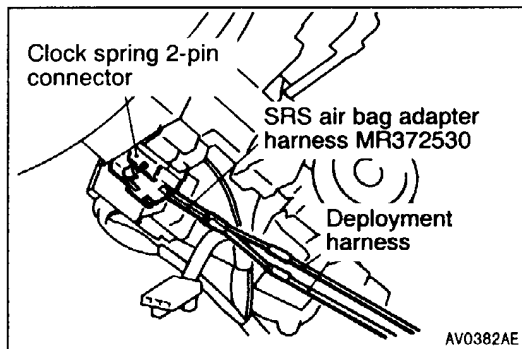

- (4) Connect the SRS air bag adapter harness to the clock spring 2-pin connector and route the deployment harnesses out of the vehicle.

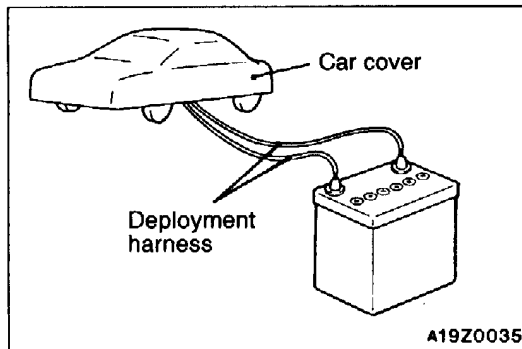

- (5) Close all the doors with the windows fully closed and put a cover over the vehicle to minimize report.

Caution

The cover is required as the glass, if already damaged, may break.

- (6) Separate the deployment harnesses as far from the vehicle as possible and connect to the terminals of the battery removed from the vehicle. Then deploy the passenger's air bag module.

Caution

- 1) **Before deploying the air bag, see that no one is in and near the vehicle.**
 - 2) **The deployment makes the inflator of the driver's air bag very hot. Before handling the inflator, wait more than 30 minutes for cooling.**
 - 3) **If the air bag module fails to deploy although the procedure is respected, do not go near the module. Contact your distributor.**
- (7) After deployment of the air bag module, discard as specified in the procedure. (Refer to P.52B-52)

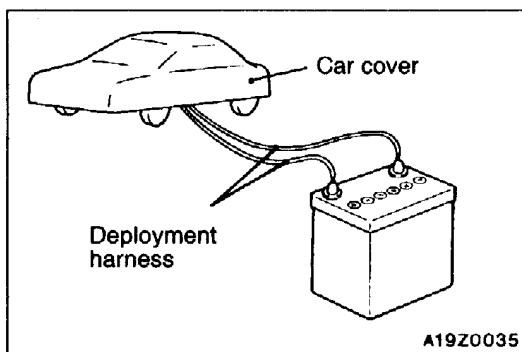
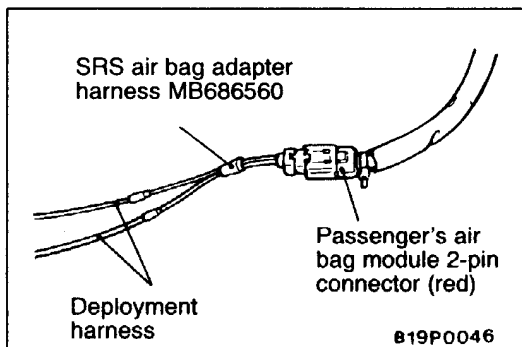
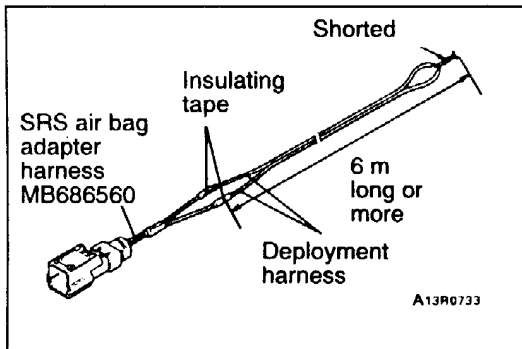
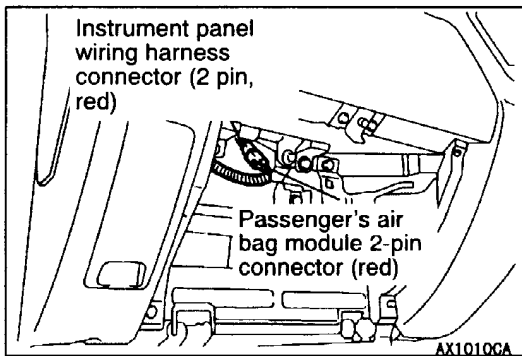

Passenger's air bag module

- (1) Remove the glove box.
(Refer to GROUP 52A – Instrument Panel.)
- (2) Disconnect the front passenger's air bag module 2-pin connector (red) and instrument panel wiring harness connector (2-pin, red).

NOTE

Once disconnected from the instrument panel wiring harness, both electrodes of the passenger's air bag module short automatically. This prevents the passenger's air bag from accidental deployment caused by static, etc.

- (3) Connect deployment harnesses longer than 6 m to each SRS air bag adapter harness and insulate the connections with plastic tape.
Also, connect the deployment harnesses in the other ends to short, thereby preventing the passenger's air bag from accidental deployment caused by static etc.

- (4) Connect the SRS air bag adapter harness to the passenger's air bag module 2-pin (red) connector and route the deployment harnesses out of the vehicle.

- (5) Close all the doors with the windows fully closed and put a cover over the vehicle to minimize report.

Caution

The cover is required as the glass, if already damaged, may break.

- (6) Separate the deployment harnesses as far from the vehicle as possible and connect to the terminals of the battery removed from the vehicle. Then deploy the passenger's air bag module.

Caution

- 1) **Before deploying the air bag, see that no one is in and near the vehicle.**
- 2) **The deployment makes the inflator of the passenger's air bag very hot. Before handling the inflator, wait more than 30 minutes for cooling.**
- 3) **If the air bag module fails to deploy although the procedure is respected, do not go near the module. Contact your local distributor.**
- (7) After deployment of the air bag module, discard as specified in the procedure. (Refer to P.52B-52)

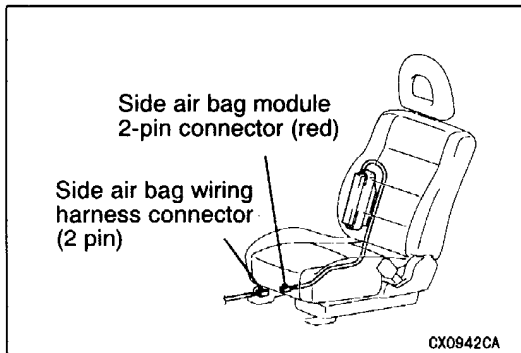

Side air bag module

- (1) Disconnect the side airbag module 2-pin connector (red) and side airbag wiring harness connector (2-pin).

Caution

The side air bag modules both in the driver's and passenger's sides should be deployed.

NOTE

Once disconnected from the side air bag wiring harness, both electrode of the side air bag module connector short automatically. This prevents the side air bag from accidental deployment caused by static etc.

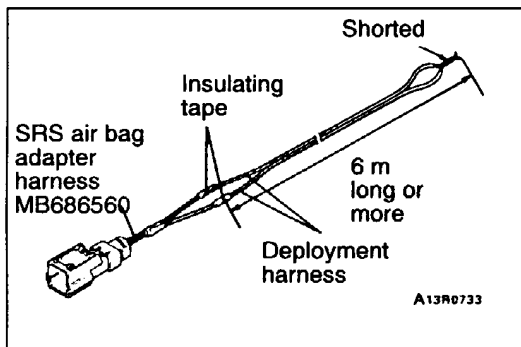

- (2) Connect deployment harnesses longer than 6 m to each SRS air bag adapter harness and insulate the connections with plastic tape. Also, connect the deployment harnesses in the other ends to short, thereby preventing the side air bag from accidental deployment caused by static etc.

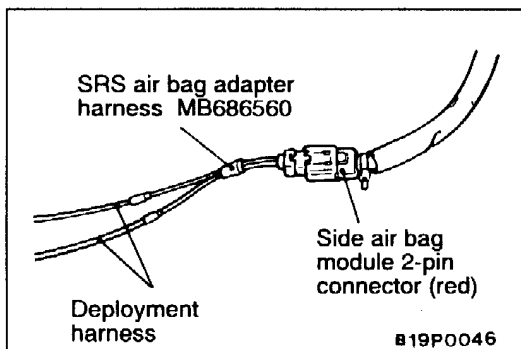

- (3) Connect the SRS air bag adapter harness to the side air bag module 2-pin connector (red) and route the deployment harness out of the vehicle.

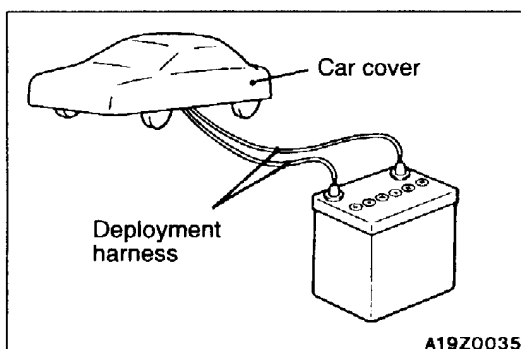

- (4) Close all the doors with the windows fully closed and put a cover over the vehicle to minimize report.

Caution

The cover is required as the glass, if already damaged, may break.

- (5) Separate the deployment harnesses as far from the vehicle as possible and connect to the terminals of the battery removed from the vehicle. Then deploy the side air bag module.

Caution

- 1) Before deploying the air bag, see that no one is in and near the vehicle.
 - 2) The deployment of the side air bag makes the inflator very hot. Before handling the inflator, wait more than 30 minutes for cooling.
 - 3) If the air bag module fails to deploy when the procedures above are followed, do not go near the module. Contact your local distributor.
- (6) After deployment of the air bag module, discard as specified in the procedure. (Refer to P.52B-52.)

DEPLOYMENT OUTSIDE THE VEHICLE**Caution**

1. This should be carried out in a wide, flat area at least 6 m away from obstacles and other people.
2. Do not deploy outside if wind is high. Even in a soft wind, ignite to windward of the air bag modules.

1. Disconnect the negative (-) and positive (+) battery cables from the battery terminals, and then remove the battery from the vehicle.

Caution

Wait at least 60 seconds after disconnecting the battery cables before doing any further work. (Refer to P.52B-4, item 5 of the Service Precautions)

2. Deploy each air bag module as specified in the service procedures that follows.

Driver's air bag module

- (1) Remove the driver's air bag module from the vehicle. (Refer to P.52B-32)

Caution

Once disconnected, both electrodes of the driver's air bag module connector short automatically to prevent accidental deployment caused by static etc. Still in consideration of the accidental deployment, store the air bag module on flat place with deployment surface facing up. Do not place anything on top of it.

- (2) Connect two wires, each 6 meters or longer, to the two leads of SRS air bag adapter harness and cover the connections with insulation tape. The other ends of the two wires should be connected to each other (short-circuited), to prevent sudden unexpected deployment of the driver's air bag.
- (3) Touch the vehicle's body with bare hands to discharge static in you.

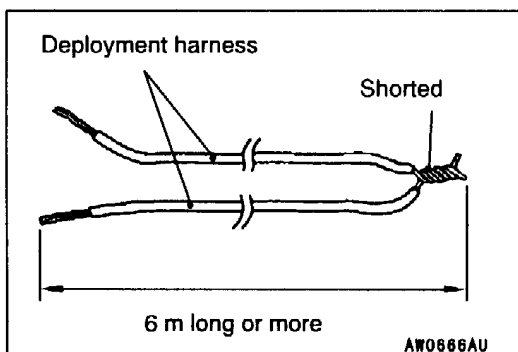

Caution

Never fail to do Step (3) in order to prevent accidental deployment caused by static.

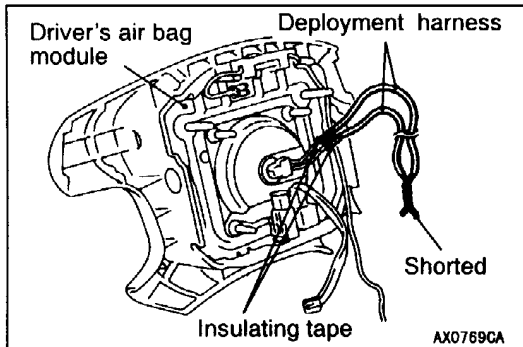

- (4) Using pliers, cut the driver's air bag module connector from the harnesses. Connect the deployment harnesses to each harness that has been cut and insulate the connections with plastic tape.

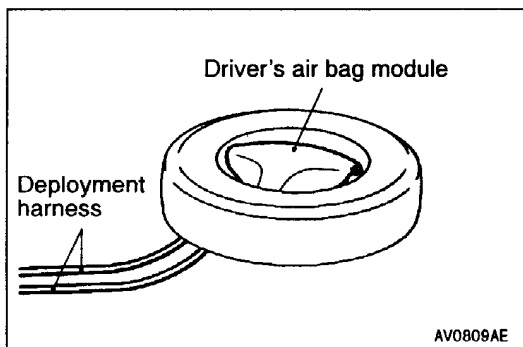

- (5) Install a nut to the bolt behind the driver's air bag module and tie thick wire for securing to the wheel.
- (6) Take the SRS air bag adapter harness that is connected to the wires, pass it beneath the old tyre wheel assembly, and connect it to the driver's air bag module. With the driver's air bag module upwards, place it in the wheel of old tyre and secure with the wire tied to the bolt.

Caution

The deployment harnesses must not be tight below the wheel. Otherwise, the adapter harness could get damaged at deployment.

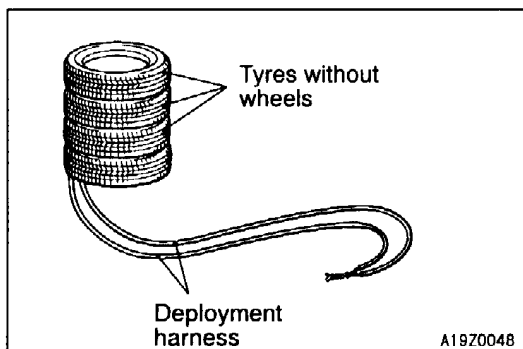

- (7) Place three old tyres without wheels on top of the tyre secured to the driver's air bag module.

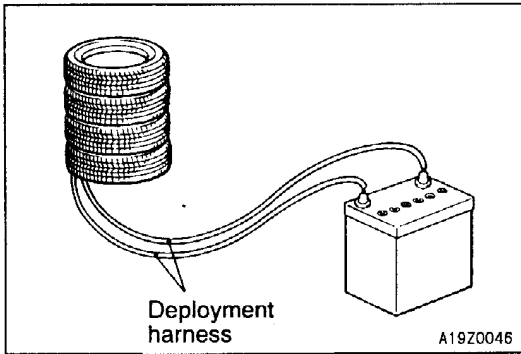

- (8) Disconnect the deployment harnesses as far from the driver's air bag module as possible and connect the wires to the terminals of the battery removed from the vehicle. Then deploy the air bag.

Caution

- 1) Before the deployment, be sure that no one is near the driver's air bag module.
 - 2) The deployment makes the inflator of the driver's air bag very hot. Before handling the inflator, wait more than 30 minutes for cooling.
 - 3) If the driver's air bag module fails to deploy although the procedure is respected, do not go near the module. Contact your distributor.
- (9) After deployment of the driver's air bag module, discard as specified in the procedure. (Refer to P.52B-52.)

Passenger's air bag module

- (1) Remove the passenger's air bag module from the vehicle.
(Refer to P.52B-32.)

Caution

Once disconnected, both electrodes of the passenger's air bag module connector short automatically to prevent accidental deployment caused by static etc. Still, in consideration of the accidental deployment, store the air bag module on flat place with deployment surface facing up. Do not place anything on top of it.

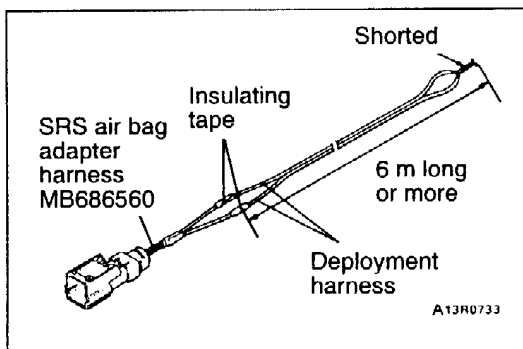

- (2) Connect deployment harnesses longer than 6 m to each SRS air bag adapter harness and insulate the connections with plastic tape. Also, connect the deployment harnesses in the other ends to short, thereby preventing the passenger's air bag from accidental deployment caused by static etc.
- (3) Route the SRS air bag adapter harness with the deployment harnesses beneath an old tyre and wheel assembly. Then, connect the harnesses to the passenger's air bag module.

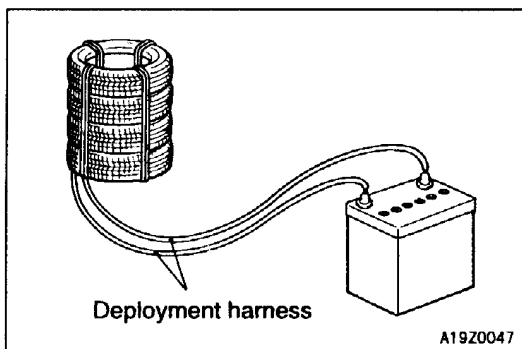
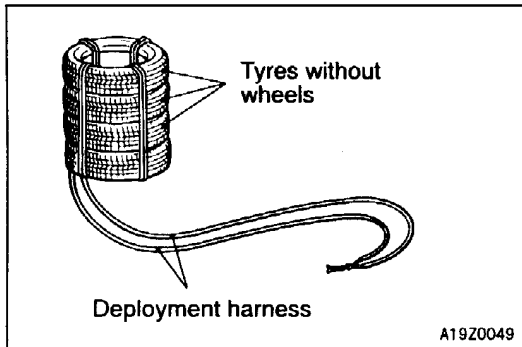
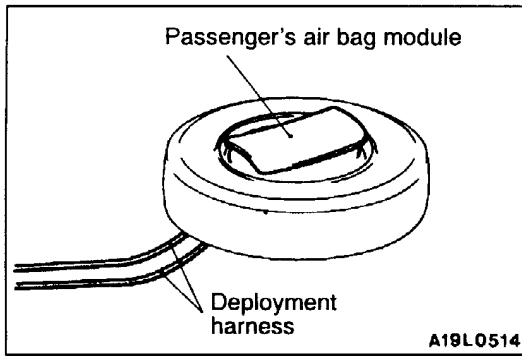

- (4) Route a thick wire through the holes in the passenger's air bag module bracket. With the deployment surface facing up, secure the passenger's air bag module to the old tyre and wheel assembly.

Caution

- 1) **The deployment harnesses must not be tight below the wheel. Otherwise, the adapter harness could get damaged at deployment.**
 - 2) **Place the connector of the SRS air bag adapter harness so that it is not clamped by the tyre at deployment.**
- (5) Put three old tyres without wheels on the tyre secured to the passenger's air bag module. Secure all the tyres with ropes (4 locations).

- (6) Disconnect the deployment harnesses as far from the passenger's air bag module as possible and connect the harnesses to the battery removed from the vehicle. Then deploy the airbag.

Caution

- 1) **Before the deployment, see that no one is near the passenger's air bag module.**
 - 2) **The deployment makes the inflator of the passenger's air bag very hot. Before handling the inflator, wait more than 30 minutes for cooling.**
 - 3) **If the passenger's air bag module fails to deploy although the procedure is respected, do not go near the module. Contact your local distributor.**
- (7) After deployment of the passenger's air bag module, discard as specified in the procedure. (Refer to P.52B-52.)

<Side air bag module>

- (1) Remove the front seat back assembly with side air bag module from the vehicle. (Refer to 52B-32.)

Caution

Once disconnected, both electrodes of the side air bag module connector short automatically to prevent accidental deployment caused by static etc. Still, in consideration of the accidental deployment, store the air bag module on flat place with deployment surface facing up. Do not place anything on top of it.

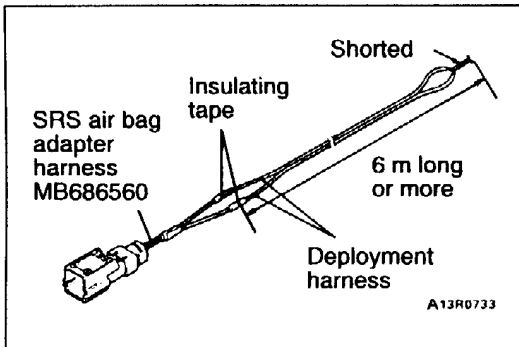

- (2) Connect deployment harnesses longer than 6 m to each SRS air bag adapter harness and insulate the connections with plastic tape. Also, connect the deployment harnesses in the other ends to short, thereby preventing the side air bag from accidental deployment caused by static etc.

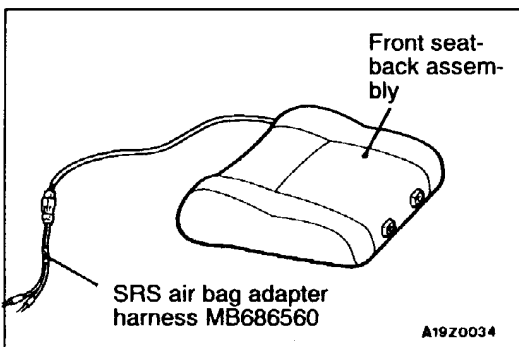

- (3) Place the front seat back assembly with its back facing the ground.
- (4) Connect the SRS air bag adapter harness which connected with the deployment harness to the side air bag module connector.

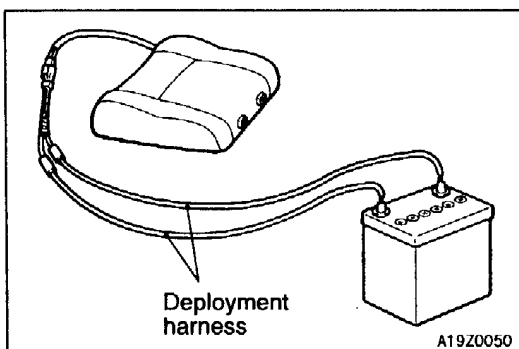

- (5) Disconnect the deployment harnesses as far from the front seat back assembly as possible and connect the harnesses to the battery removed from the vehicle. Then deploy the air bag.

Caution

- 1) Before the deployment, see that no one is near the front seat back assembly.
 - 2) The deployment of the side air bag makes the inflator very hot. Before handling the inflator, wait more than 30 minutes for cooling.
 - 3) If the side air bag module fails to deploy when the procedures above are followed, do not go near the module. Contact your local distributor.
- (6) Remove the deployed side air bag module from the seat back assembly and discard as specified in the procedure. (Refer to P.52B-52.)

DEPLOYED AIR BAG MODULE DISPOSAL PROCEDURES

After the deployment, discard the air bag modules the same way as any other scrap parts, respecting local laws and/or legislation that may be in force.

However, note the following points at the disposal:

1. The inflators will be quite hot just after deployment. So, wait at least 30 minutes to cool it before handling.
2. Do not put water or oil on the air bags after deployment.
3. There may be, adhered to the deployed air bag modules, material that could irritate the eye and/or skin, so put on gloves and safety glasses when handling the deployed air bag module.

Caution

If after following these precautions, any material does get into the eyes or on the skin, immediately rinse the affected area with a large amount of clean water. If any irritation develops, seek medical attention.

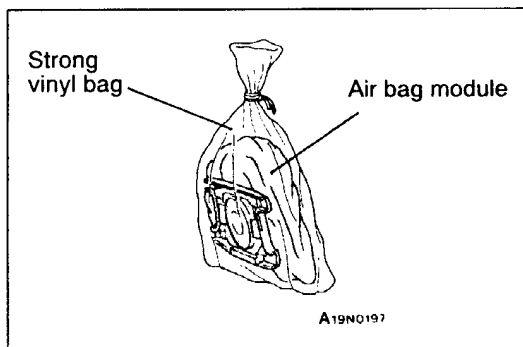

4. Discard the air bag module in a vinyl bag tightly sealed.
5. Be sure to always wash your hands after completing this operation.