MANUAL TRANSMISSION

CONTENTS

GENERAL INFORMATION	2	4WD Detection Switch Continuity Check <V5MT1>	7
LUBRICANTS	2	High/Low Detection Switch Continuity Check <V5MT1>	7
SEALANTS	2	TRANSMISSION CONTROL <V5MT1>	8
SPECIAL TOOL	2	TRANSMISSION CONTROL <V5MT3>	9
TROUBLESHOOTING <SS4 II>	3	TRANSMISSION ASSEMBLY	10
ON-VEHICLE SERVICE	6	4WD INDICATOR-ECU/TRANSFER-ECU	17
Transmission Oil Check	6		
Oil Replacement	6		

GENERAL INFORMATION

Items		Specifications			
Transmission model		V5MT1	V5M31		
Engine model		4D5	4D5	4M4	6G7
Type		5-speed, floor-shift			
Gear ratio	1st	3.918	3.952	4.234	
	2nd	2.261	2.238		
	3rd	1.395	1.398		
	4th	1.000			
	5th	0.829	0.819	0.761	0.819
	Reverse	3.925	3.553		
Transfer type		2-speed			
Gear ratio	High	1.000			
	Low	1.925	1.900		

LUBRICANTS

Items	Specified lubricants	Quantity L
Transmission oil	Hypoid gear oil SAE 75W-90 or 75W-85W conforming to API GL-4	3.2
Transfer oil	Hypoid gear oil SAE 75W-90 or 75W-85W conforming to API GL-4	2.5

SEALANTS

Items	Specified sealant	Remarks
Oil filler plug	3M ATD Part No. 8660 or equivalent	Semi-drying sealant
Oil drain plug	3M ATD Part No. 8660 or equivalent	Semi-drying sealant

SPECIAL TOOL

Tool	Number	Name	Use
	MD998464	Test harness (4P, square)	Inspection of lever position sensor

TROUBLESHOOTING <SS4 II>

For items other than the following service procedures, refer to GROUP 23 – Troubleshooting <SS4 II>.

INSPECTION CHART FOR DIAGNOSIS CODES

Diagnosis code	Diagnosis item	Reference page
21	Lever position sensor (LPS) system <4D5> Open circuit/Malfunction of sensor	22-3

INSPECTION PROCEDURE FOR DIAGNOSIS CODES

Code No.21 Lever position sensor (LPS) system <4D5>	Probable cause
If the LPS output voltage becomes 0.2 V or less at idling, code No.21 will be set as open circuit or maladjustment of the LPS.	<ul style="list-style-type: none"> • Malfunction of the LPS • Malfunction of harness or connector • Malfunction of transfer-ECU • Malfunction of the glow-ECU

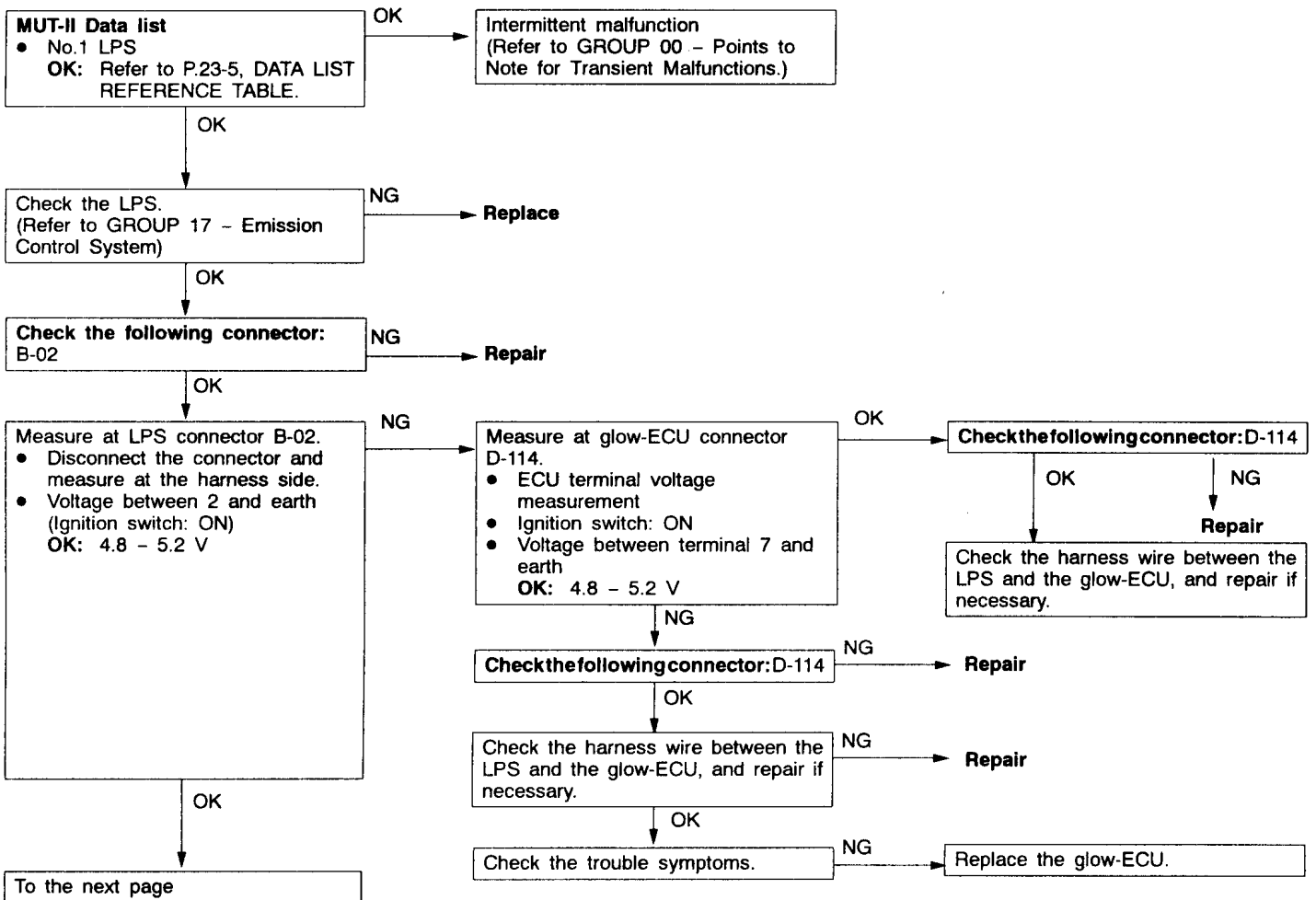

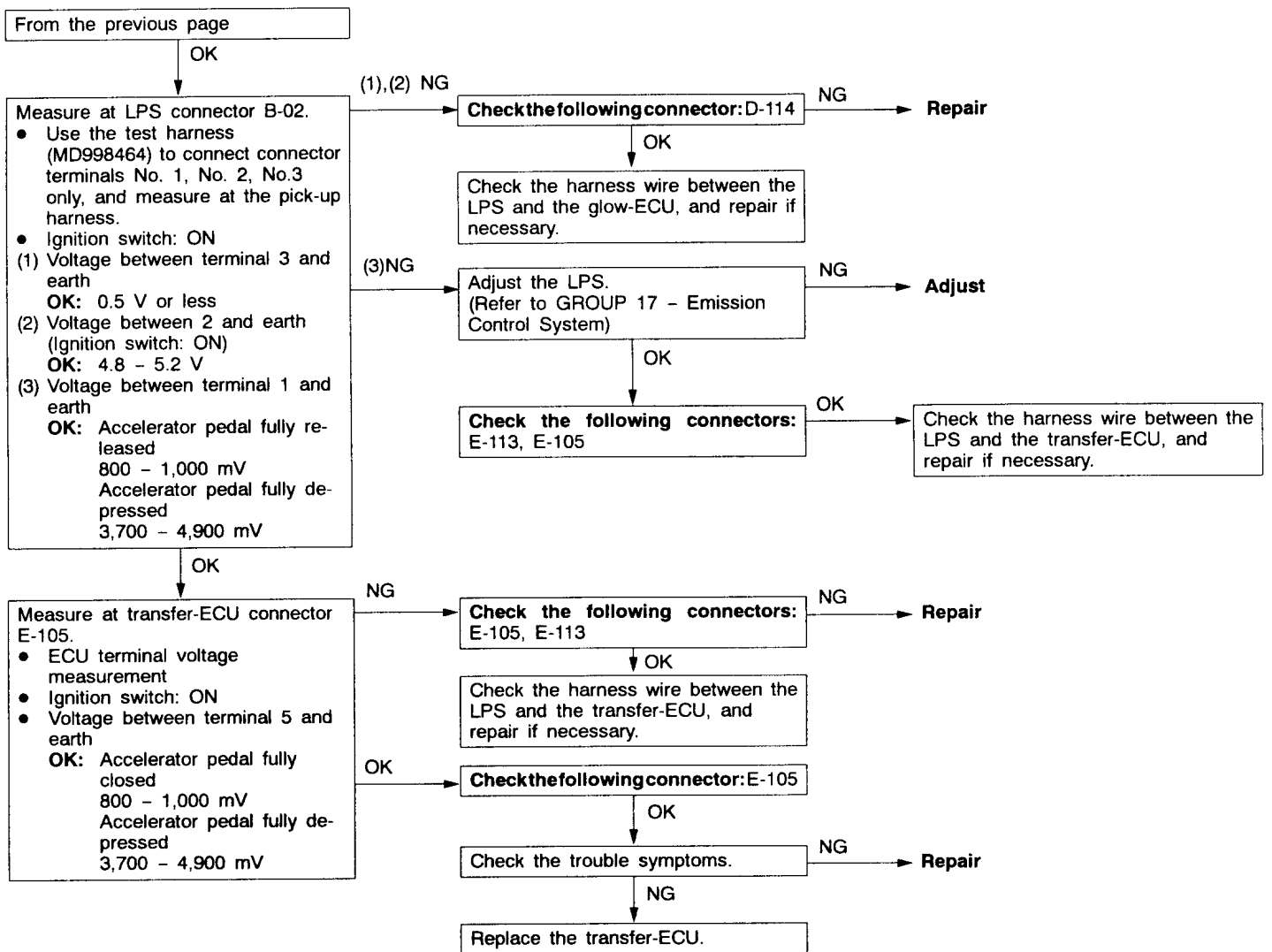

DATA LIST REFERENCE TABLE

Data list No.	Check item	Check conditions	Normal condition
1	Lever position sensor (LPS) <4D5>	Engine: Stopped	Accelerator pedal: Fully closed
		Selector lever position: P	Accelerator pedal: Depressed
			Accelerator pedal: Fully open
			800 – 1,000 mV
			Gradually increases from the above value.
			3,700 – 4,900 mV

CHECK AT TRANSFER-ECU TERMINAL

Terminal No.	Check item	Check conditions	Standard value
5	Lever position sensor (LPS) <4D5>	Accelerator pedal: Fully closed (engine stopped)	0.8 – 1.0 V
		Accelerator pedal: Fully open (engine stopped)	3.7 – 4.9 V

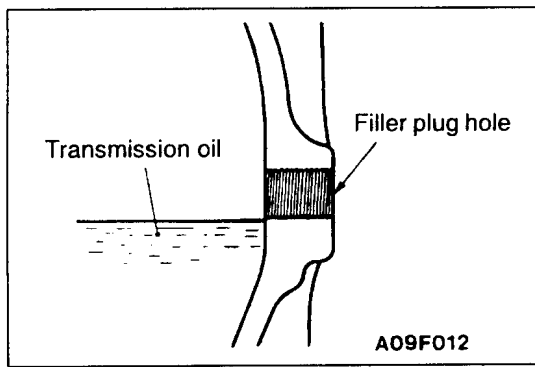

ON-VEHICLE SERVICE

TRANSMISSION OIL CHECK

1. Remove the oil filler plug.
2. Oil level should be at the lower portion of the filler plug hole.
3. Check that the transmission oil is not noticeably dirty, and that it has a suitable viscosity.
4. Tighten the filler plug to the specified torque.

Tightening torque: 32 ± 2 N·m

OIL REPLACEMENT

1. Remove oil filler plug and oil drain plug.
2. Drain oil.
3. Apply sealant to the oil drain plug threads.
4. Tighten the oil drain plug to the specified torque.

Tightening torque:

V5MT1 39 ± 5 N·m

V5M31 32 ± 2 N·m

Transfer 32 ± 2 N·m

Specified sealant:

3M ATD Part No. 8660 or equivalent

5. Fill with specified oil till the level comes to the lower portion of oil filler plug hole.

Specified transmission oil:

Hypoid gear oil SAE 75W-90 or 75W-85W conforming to API GL-4

Quantity:

Transmission 3.2 L

Transfer 2.5 L

6. Apply sealant to the oil filler plug threads.
7. Tighten the oil filler plug to the specified torque.

Tightening torque: 32 ± 2 N·m

Specified sealant:

3M ATD Part No. 8660 or equivalent

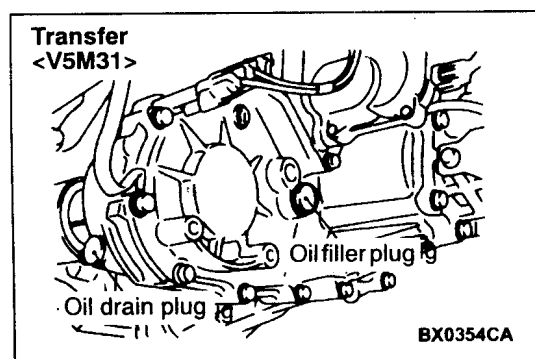
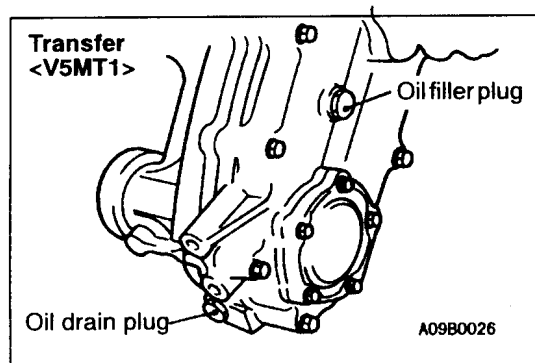
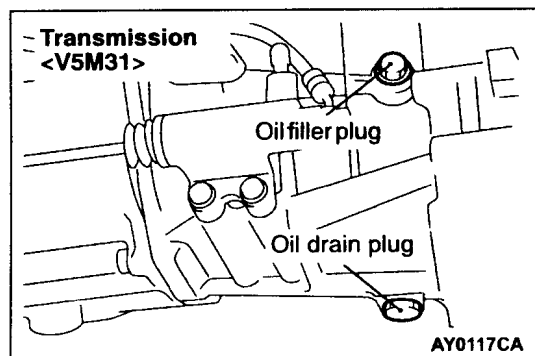
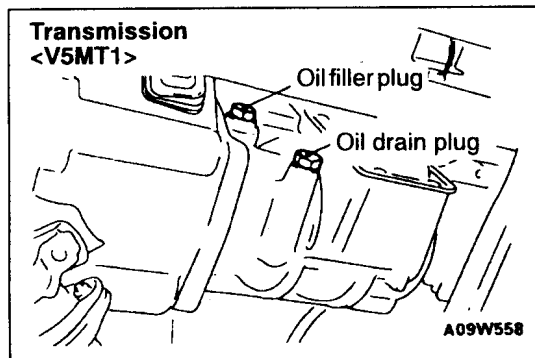

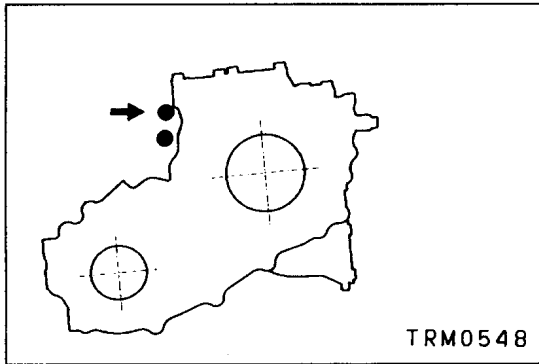

4WD DETECTION SWITCH CONTINUITY CHECK <V5MT1>

Check the continuity between terminals of the black connector indicated in the illustration.

Transfer lever position	Terminal No.	
	1	2
2H		
4H	○	○

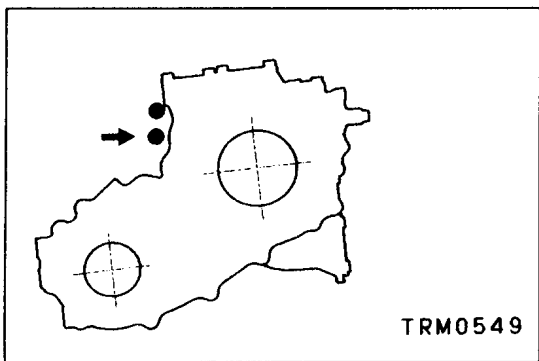

HIGH/LOW DETECTION SWITCH CONTINUITY CHECK <V5MT1>

Check the continuity between terminals of the gray connector indicated in the illustration.

Transfer lever position	Terminal No.	
	1	2
4H	○	○
4L	○	○
4H-4L		

TRANSMISSION CONTROL <V5MT1>

REMOVAL AND INSTALLATION

Pre-removal Operation

- Shift the Transmission Control Lever to the N Position.
- Shift the Transfer Control Lever to the 4H Position.

Post-installation Operation

Check the Operation of the Transmission and Transfer Control Levers and the Movement in Each Lever Position.

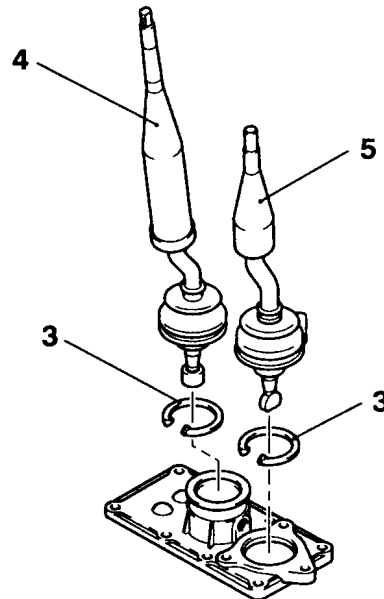
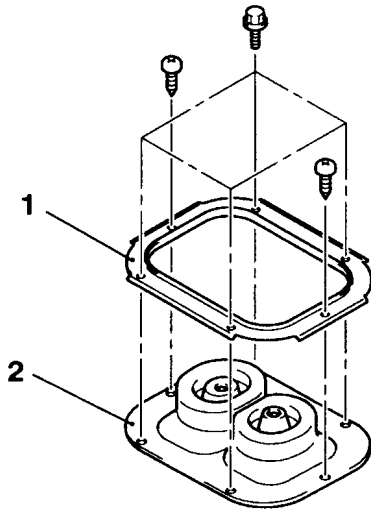

AY0150CA

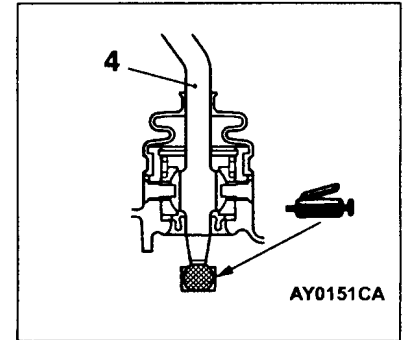
**Transmission control lever assembly removal steps**

- Indicator panel (Refer to GROUP 52A – Floor Console)
1. Retainer plate
 2. Shift control boot
 3. Snap ring
 4. Transmission control lever assembly

Transfer control lever assembly removal steps

- Indicator panel (Refer to GROUP 52A – Floor Console)
1. Retainer plate
 2. Shift control boot
 3. Snap ring
 5. Transfer control lever assembly

TRANSMISSION CONTROL <V5MT3>

REMOVAL AND INSTALLATION

Pre-removal Operation

Shift the Transmission Control Lever to the N Position.

Post-installation Operation

Check the Operation of the Transmission and Transfer Control Levers and the Movement in Each Lever Position.

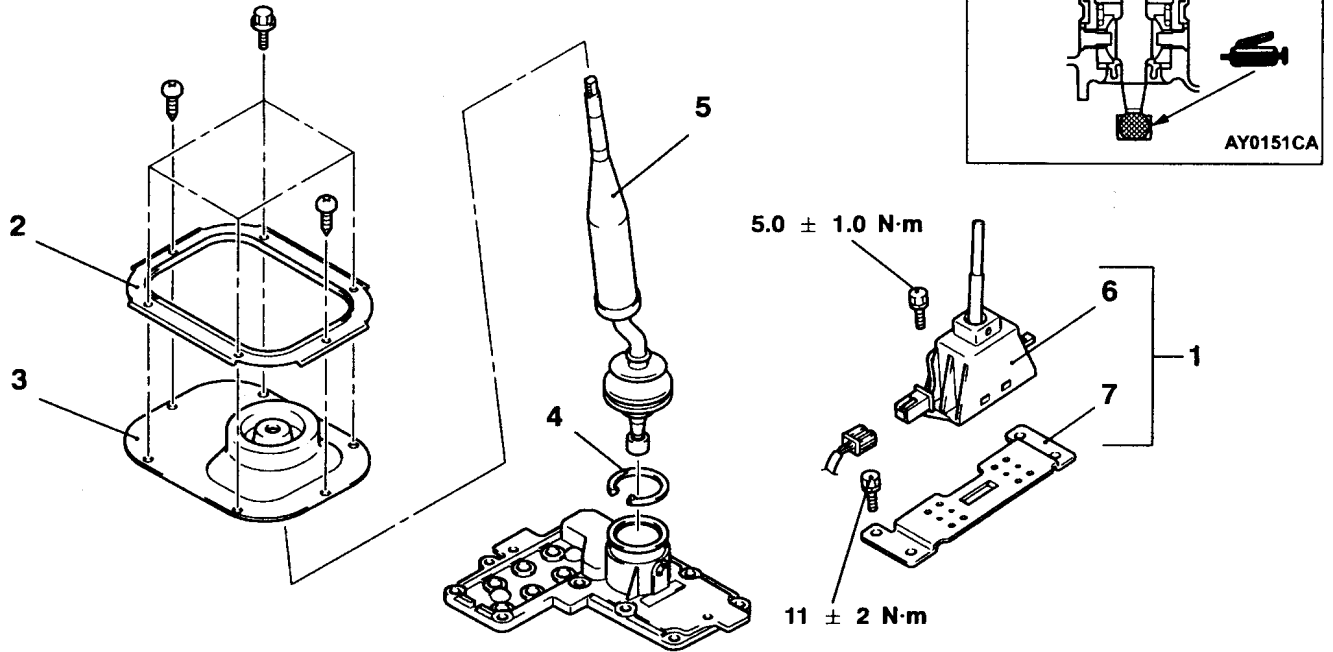

AY0146CA

Transmission control lever assembly removal steps

- Indicator panel (Refer to GROUP 52A – Floor Console)
- 1. Transfer select switch assembly
- 2. Retainer plate
- 3. Shift control boot
- 4. Snap ring
- 5. Transmission control lever assembly

Transfer select switch assembly removal steps

- Indicator panel (Refer to GROUP 52A – Floor Console)
- 6. Transfer select switch
- 7. Transfer select switch bracket

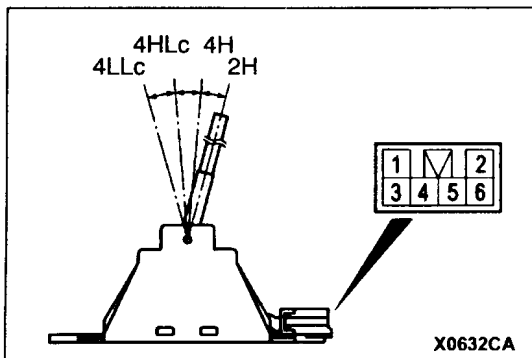

X0632CA

INSPECTION

TRANSFER SELECT SWITCH CONTINUITY CHECK

Switch position	Terminal number				
	1	2	3	5	6
2H	○		○		
4H	○			○	
4HLc	○				○
4LLc	○	○			

TRANSMISSION ASSEMBLY

REMOVAL AND INSTALLATION

Caution

The rear propeller shaft is made of fiber-reinforced plastic tube, so always refer to GROUP 25 prior to its removal.

Pre-removal Operation

- Transmission and Transfer Control Lever Removal (Refer to P.22-8.)
- Transmission and Transfer Oil Draining (Refer to P.22-6.)
- Front and Rear Propeller Shaft Removal (Refer to GROUP 25 – Propeller Shaft.)
- Front and Center Exhaust Pipe Removal (Refer to GROUP 15 – Exhaust Pipe and Main Muffler)

Post-installation Operation

- Front and Center Exhaust Pipe Installation (Refer to GROUP 15 – Exhaust Pipe and Main Muffler)
- Front and Rear Propeller Shaft Installation (Refer to GROUP 25 – Propeller Shaft.)
- Transmission and Transfer Oil Filling (Refer to P.22-6.)
- Transmission and Transfer Control Lever Installation (Refer to P.22-8.)
- Transmission and Transfer Control Lever Operation Check

<4D5 with V5MT1>

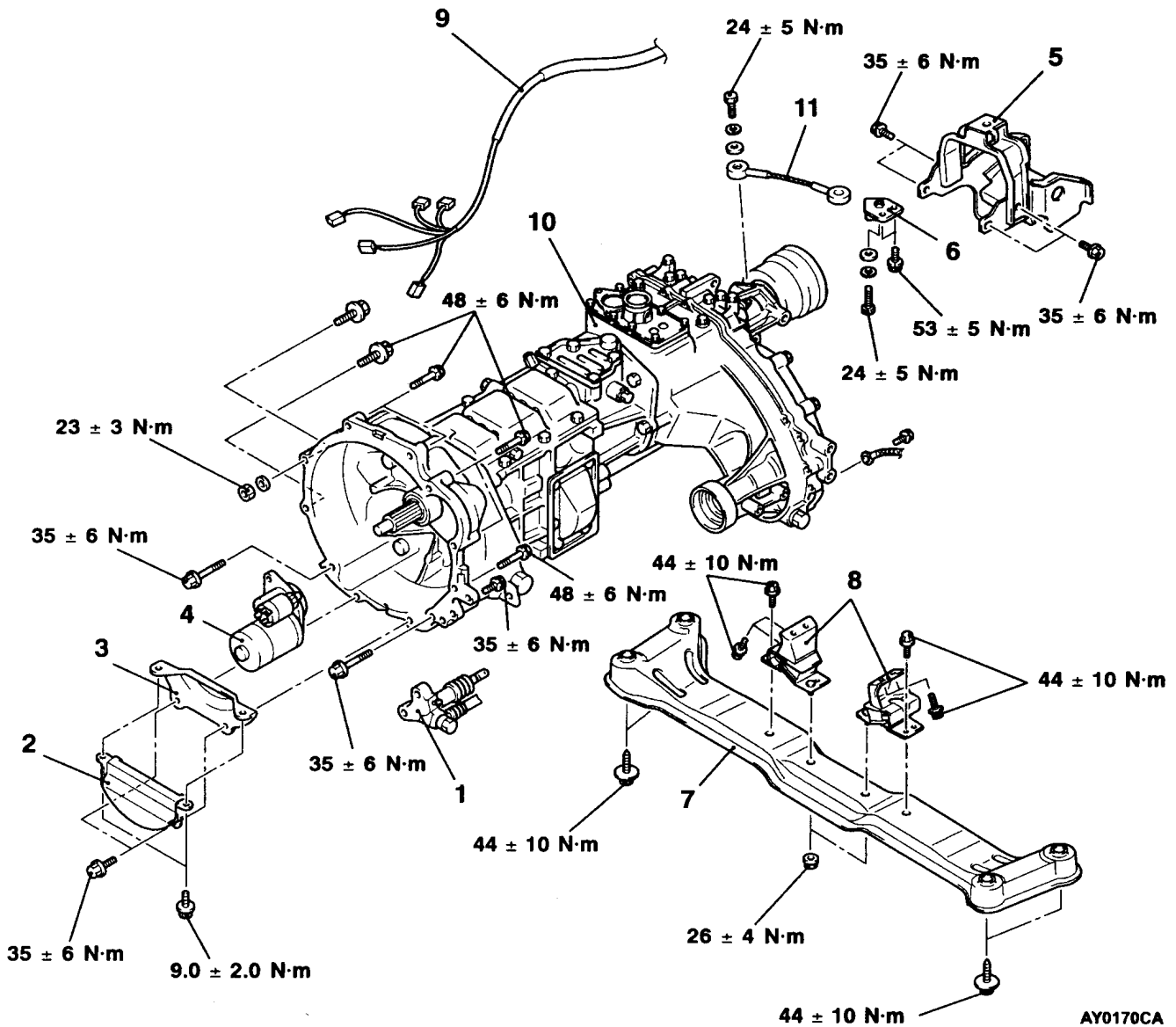

AY0170CA

<4D5 with V5M31>

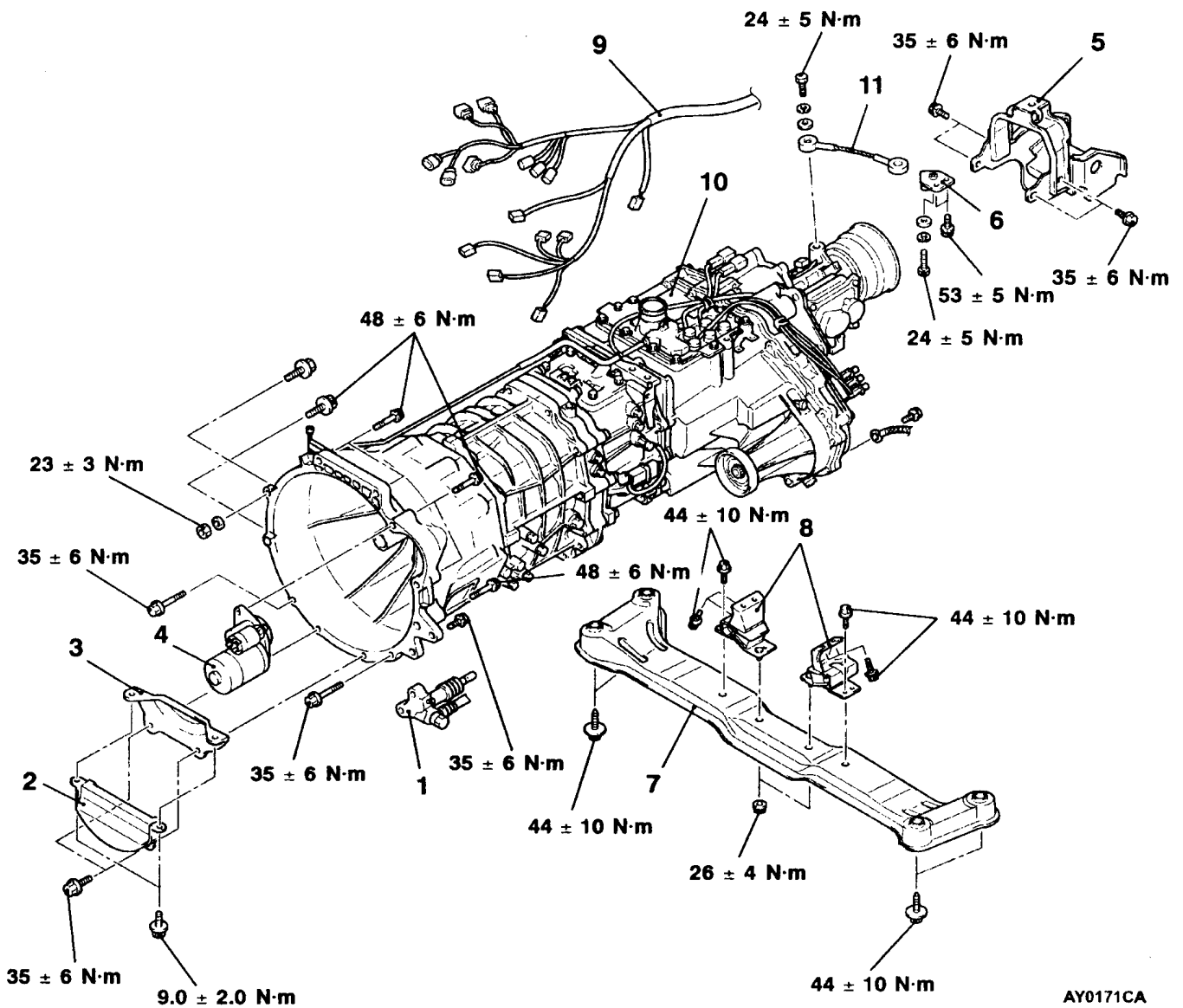

AY0171CA

Removal steps

1. Clutch release cylinder
2. Space rubber
3. Bell housing cover
4. Starter motor
5. Dynamic damper assembly
6. Tension wire bracket
- Support the transmission with a transmission jack



7. Transmission mount center member assembly
8. Transmission mount insulator assembly
9. Transmission wiring harness connector connection
10. Transmission assembly
11. Tension wire

<4M4 with V5M31>

Pre-removal and Post-installation Operations

- Skid Plate and Under Cover Removal and Installation
- Transmission Fluid and Transfer Oil Draining and Refilling (Refer to P.22-6.)
- Front and Rear Propeller Shaft Removal and Installation (Refer to GROUP 25.)
- Front Exhaust Pipe and Catalytic Converter Removal and Installation (Refer to GROUP 15.)
- Radiator Shroud Lower Cover Removal and Installation (Refer to GROUP 14.)
- Intercooler Removal and Installation (Refer to GROUP 15)

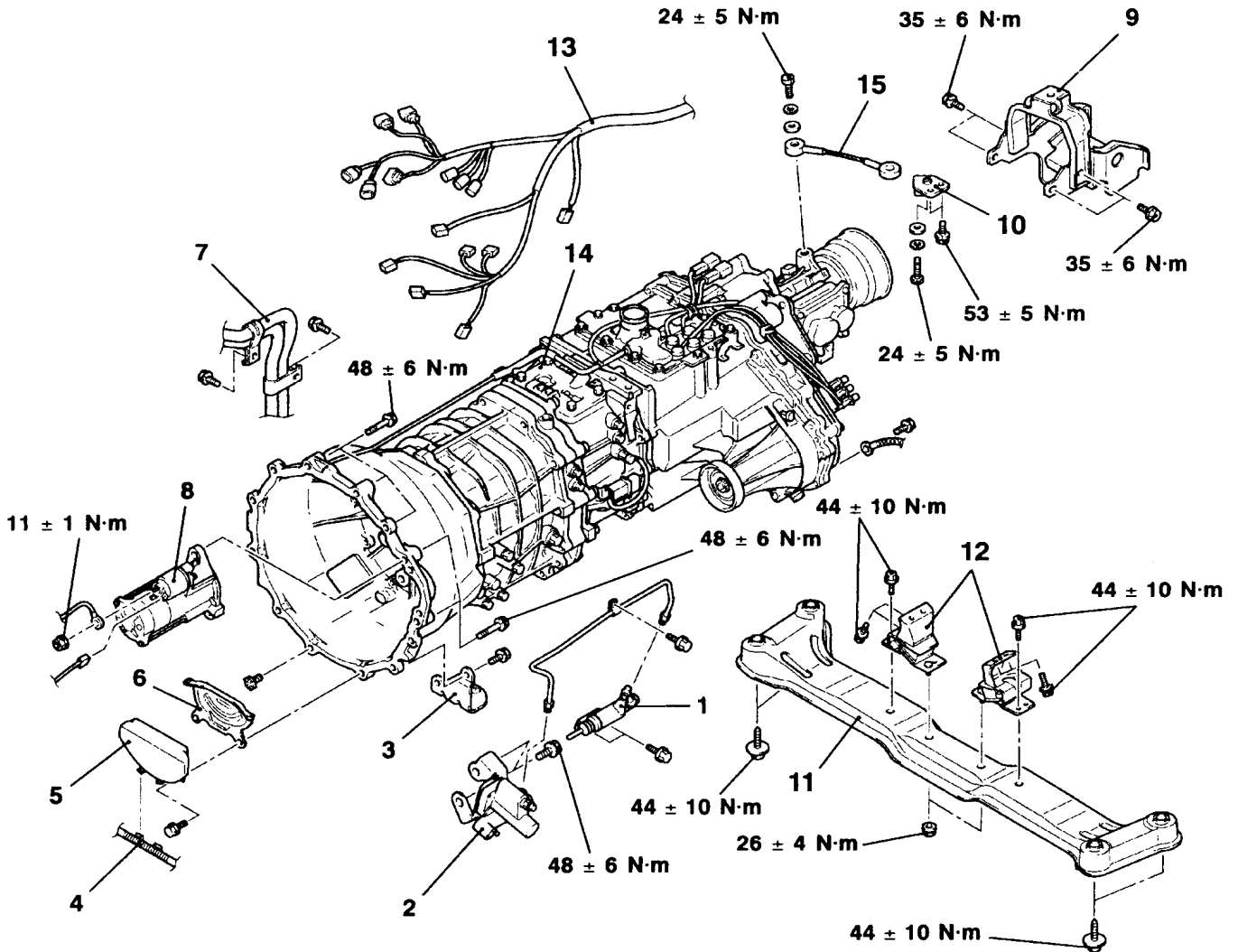

AY0172CA

Removal steps

- | | |
|---|--|
| <ol style="list-style-type: none"> 1. Clutch release cylinder (Refer to GROUP15) 2. Clutch dumper assembly (Refer to GROUP15) 3. Exhaust support bracket | <ol style="list-style-type: none"> 4. Battery cable connection 5. Spacing rubber 6. Dust cover 7. Heater hose connection 8. Starter motor |
|---|--|

- 9. Dynamic damper
- 10. Tension wire bracket
 - Support the transmission with a transmission jack
- 11. Transmission mount center member assembly
- 12. Transmission mount insulator assembly

◀A▶

◀B▶

▶A◀

- 13. Transmission harness connector connection
 - Clutch release bearing disconnection
- 14. Transmission assembly
- 15. Tension wire

<6G7 with V5M31>

Pre-removal and Post-installation Operations

- Skid Plate and Under Cover Removal and Installation
- Transmission Fluid and Transfer Oil Draining and Refilling (Refer to P.22-6.)
- Front and Rear Propeller Shaft Removal and Installation (Refer to GROUP 25.)
- Front Exhaust Pipe Removal and Installation (Refer to GROUP 15.)
- Radiator Shroud Lower Cover Removal and Installation (Refer to GROUP 14.)

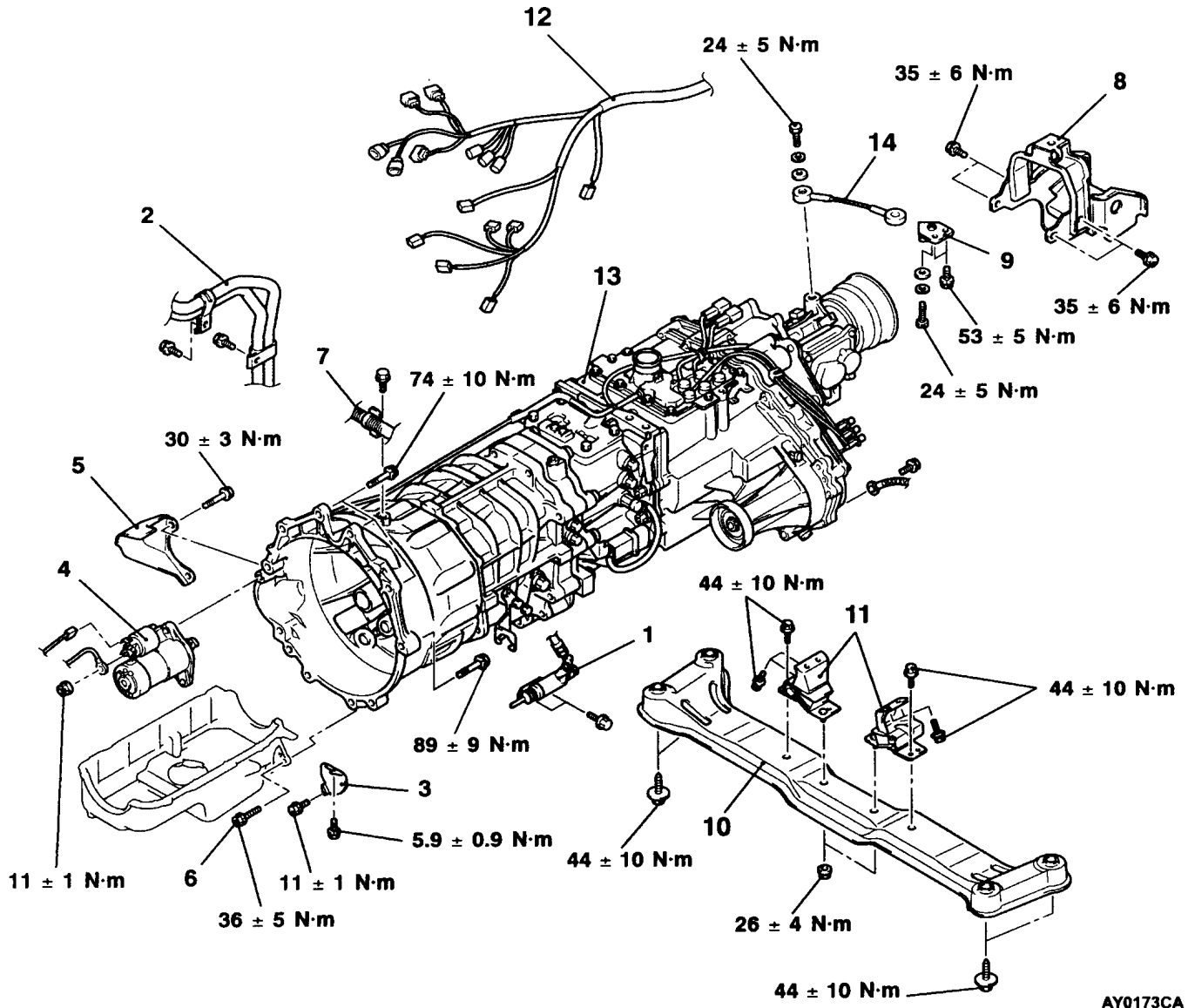

Removal steps

1. Clutch release cylinder
(Refer to GROUP15)
2. Heater hose connection
3. Cover
4. Starter motor
5. Starter cover
6. Oil pan connection bolts
7. Battery cable connection
8. Dynamic damper
9. Tension wire bracket

- Support the transmission with a transmission jack
- 10. Transmission mount center member assembly
- 11. Transmission mount insulator assembly
- 12. Transmission harness connector connection
- Clutch release bearing disconnection
- 13. Transmission assembly
- 14. Tension wire

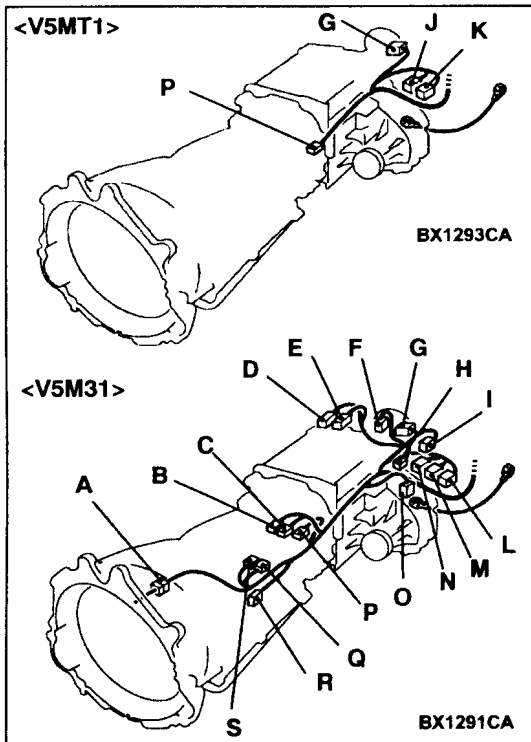

REMOVAL SERVICE POINT

<A> TRANSMISSION WIRING HARNESS CONNECTOR DISCONNECTION

1. Lower the transmission to a position where the transmission harness connector can be disconnected, and then disconnect the connector.
2. Place the disconnected transmission harness so that it stays on the vehicle body.

Code	Connector name
A	Transmission wiring harness and battery wiring harness combination
B	Select rail switch <4M4>
C	1st and 2nd rail switch <4M4>
D	4LLC (Direct low range 4WD) switch
E	2WD operation detection switch
F	Rear propeller shaft speed sensor
G	Vehicle speed sensor
H	Oxygen sensor (Rear)
I	Shift actuator
J	High range/low range detection switch
K	4WD operation detection switch
L	2WD/4WD detection switch
M	4H (Full time 4WD) switch
N	Center differential lock detection switch
O	Front propeller shaft speed sensor
P	Back-up lamp switch
Q	Oxygen sensor (Front)
R	Back-up lamp switch <4M4>
S	3rd and 4th rail switch <4M4>

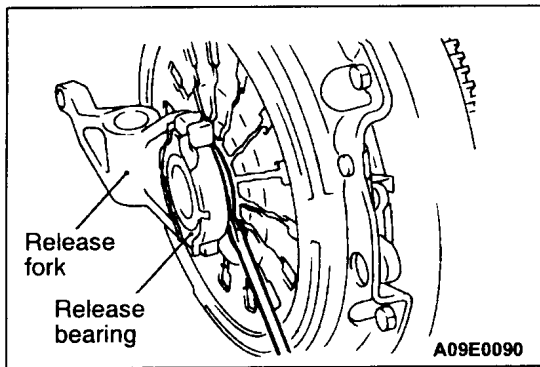

◀B▶ CLUTCH RELEASE BEARING DISCONNECTION

1. Remove the service hole cover at the clutch housing.
2. Operate the release fork, and push the release bearing towards the clutch side.
3. Insert the flat-tipped screwdriver to separate the release bearing.

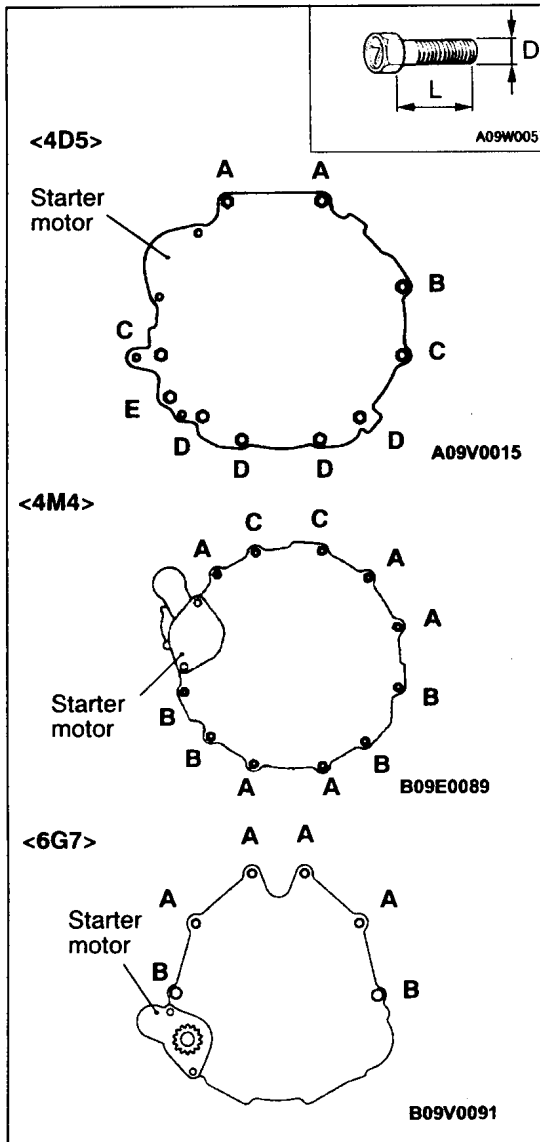

INSTALLATION SERVICE POINT

▶A◀ TRANSMISSION ASSEMBLY INSTALLATION

The sizes of the mounting bolts are different. So be sure not to confuse them.

<4D5>

Bolt	Diameter (D) x Length (L) mm
A	10 x 45
B	8 x 30
C	10 x 80
D	10 x 25
E	10 x 35

<4M4>

Bolt	Diameter (D) x Length (L) mm
A	12 x 25
B	10 x 45
C	10 x 50

<6G7>

Bolt	Diameter (D) x Length (L) mm
A	12 x 40
B	12 x 55

4WD INDICATOR-ECU/TRANSFER-ECU

REMOVAL AND INSTALLATION

Pre-removal and Post-installation Operation
 Indicator panel, Floor console front panel removal and installation
 (Refer to GROUP52A – Floor console)

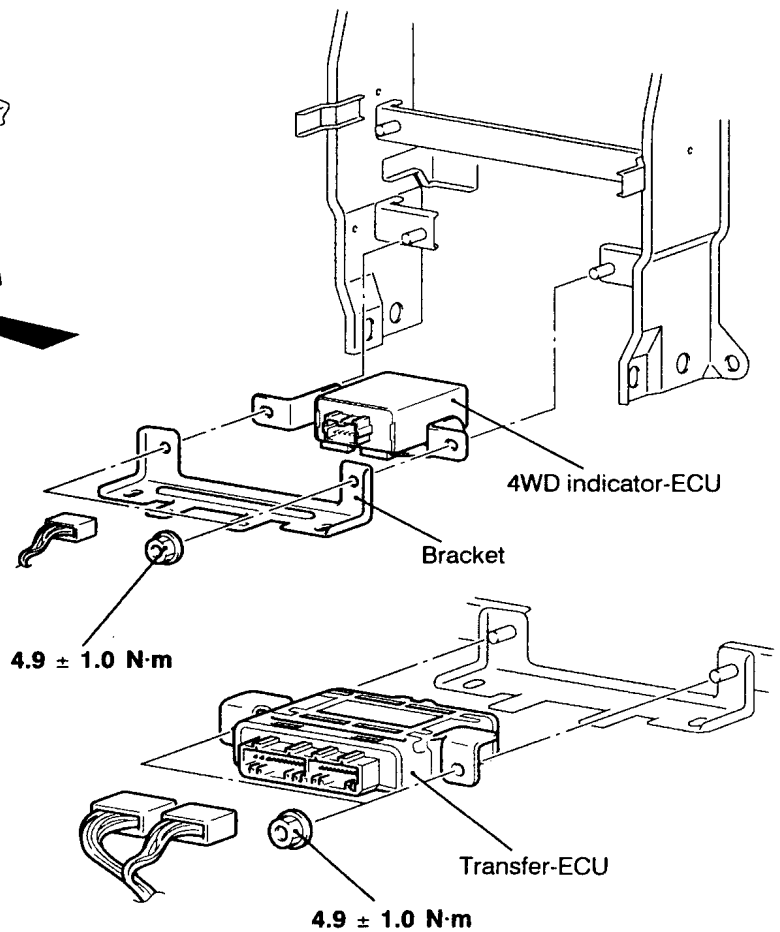
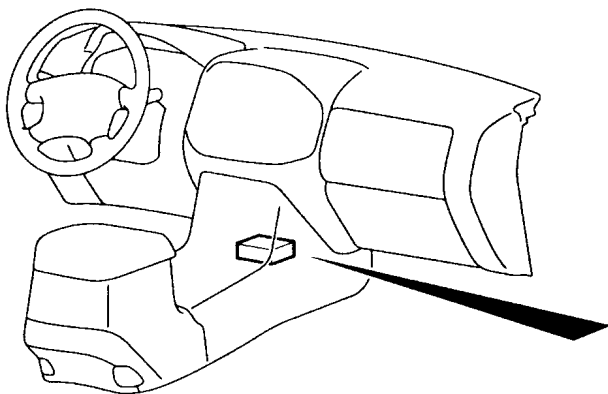

AY0153CA

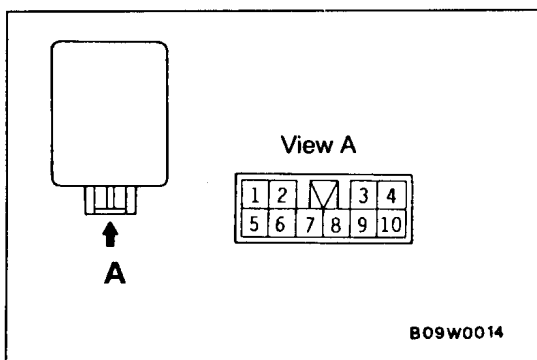

INSPECTION

4WD INDICATOR-ECU

1. Measure the voltage with the control unit and harness still connected.
2. Earth terminal (8) and then measure terminal voltage.

Terminal No.	Inspection item	Inspection condition 1: Ignition switch	Inspection condition 2: Transfer lever position	Terminal voltage
1	Free wheel engage switch	ON	2H	System voltage
			4H*1	0 V
2	4WD detection switch	ON	2H	System voltage
			4H, 4L	0 V
3	Ignition switch (IG1)	OFF	-	0 V
		ON	-	System voltage
6	HI/LOW detection switch	ON	Shifting from 4H to 4L or vice versa	System voltage
			2H, 4H, 4L	0 V
7	Free wheel clutch changeover solenoid valve	ON	4H, 4L	0 V
			2H*2	System voltage
10	4WD Indicator lamp	ON	2H	0 V
			4H, 4L	System voltage

NOTE

*1: When vehicle has been moved once.

*2: Shift the lever from 4H to 2H, and then turn the ignition switch to OFF and then back to ON.

TRANSFER-ECU

Measure the terminal voltage (Refer to P.22-3).