

COMPONENT LOCATION

110005935

Name	Symbol	Name	Symbol
Air conditioning compressor clutch relay	F	Ignition coil (Ignition power transistor)	H
Air conditioning switch	Q	Ignition timing adjustment connector	B
Camshaft position sensor	G	Injector	D
Check engine / Malfunction indicator lamp	P	Multiport fuel injection (MFI) relay	S
Crankshaft position sensor	I	Park / Neutral position switch (Vehicles with automatic transmission)	U
Data link connector	N		
Engine control module	R	Power steering pressure switch	L
Engine coolant temperature sensor	J	Throttle position sensor (with closed throttle position switch)	C
Evaporative emission purge solenoid	E		
Fuel pump check connector	A	Vehicle speed sensor (reed switch)	O
Heated oxygen sensor	T	Volume air flow sensor (with intake air temperature sensor and barometric pressure sensor)	M
Idle air control motor	K		

NOTE

The entries in the "Name" column are arranged in alphabetical order.

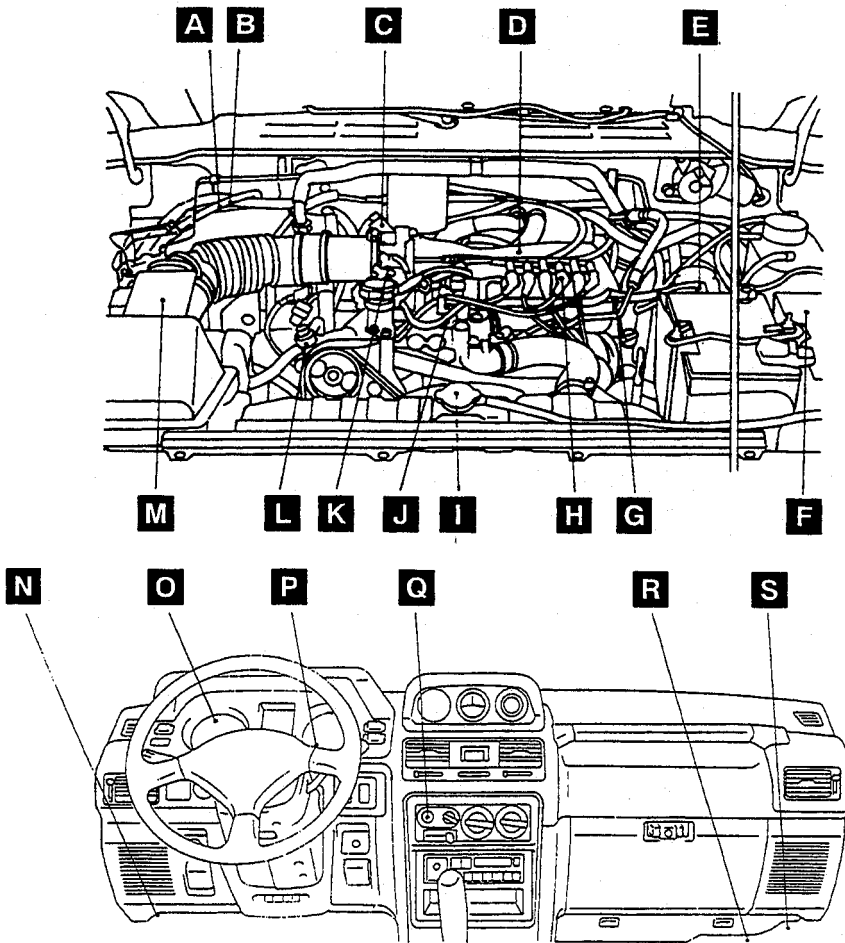

7FU1167  
7FU1681

